

The
AIRCRAFT
YEAR BOOK

For 1933

HARRISON BRAND, JR.

AIRCRAFT YEAR BOOK, 1933 .

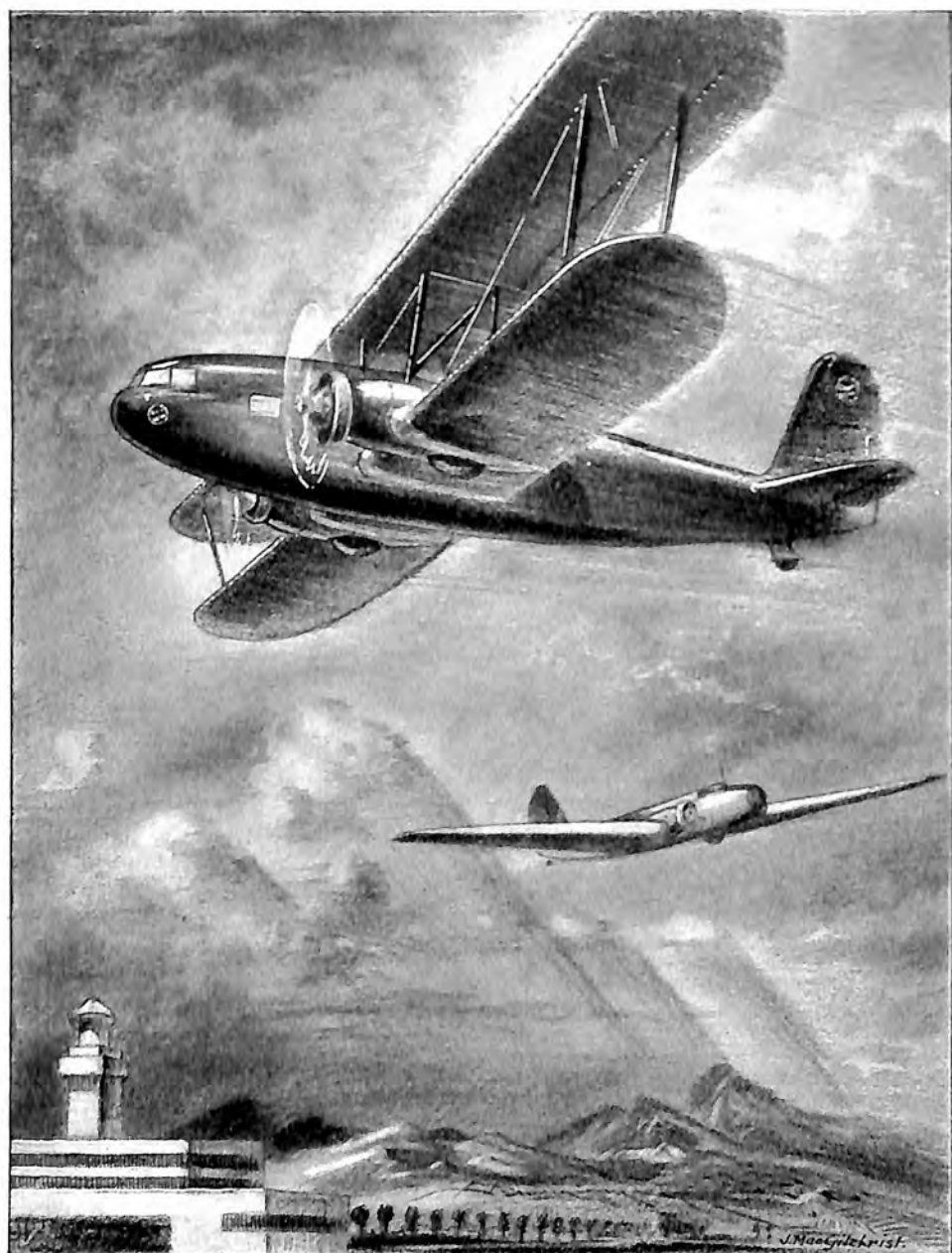

The AIRCRAFT YEAR BOOK

(Registered U. S. Patent Office)

For 1933

VOLUME FIFTEEN



Compiled, Written and Edited
By

AERONAUTICAL CHAMBER OF COMMERCE
OF AMERICA, INC.

WINGS FOR 1933
Epitomizing the year's trends in air
transport design, the Condors and
Skymasters of 1933 take the places on
the nation's airways to cut hours from
schedules already three times faster
than the speediest of surface transports.
... Drawing by John Mac Gilchrist.

Published for the Chamber
BY THE
CONDOR COMPANY, INC.
NEW YORK

Copyright, 1933, By
AERONAUTICAL CHAMBER OF COMMERCE
OF AMERICA, INC.
NEW YORK CITY

TABLE OF CONTENTS



PART I. THE YEAR IN THE AIR

CHAPTER	PAGE
I. COMPLETING THREE DECADES OF FLIGHT	1
Aviation Exceeds Fondest Dreams of Wrights in First Thirty Years of History—Depressed Economic Conditions React Against Industry—Air Transport Shows Greatest Gains—Need for National Policy Paramount.	
II. AVIATION'S INDEX TO PROGRESS	9
Passenger and Express Traffic on Scheduled Air Lines Grows—Higher Postage Rates Cut Mail Volume—Private Flying and Aerial Service Hit by Depression—Production Off—Army, Navy, Other Statistics.	
III. AIR LINES SET PACE FOR INDUSTRY	17
Technical Advances Improve Operating Efficiency—Many Faster and More Frequent Services Inaugurated—New Air Express Hookups Boost Traffic—High Air Mail Rates Cut Poundage.	
IV. "WHO'S WHO" AMONG AIR TRAVELLERS	49
Presidents and Kings Head Year's Air Passenger Lists—Many Senators and Congressmen Fly—Diplomats and Industrial Leaders Numbered Among Patrons—Every Walk of Life Represented.	
V. AIR CORPS: FIRST LINE OF LAND DEFENSE	61
United States Rated Fourth in Air Strength—Concentrate on Efficiency of New Tactical Planes—Five Year Program Still Incomplete—Annual Maneuvers Cancelled for Economy.	
VI. PREENING WINGS OF THE FLYING FLEET	69
Naval Aviation Maintains High Operations Record—Plays Prominent Role in Fleet Maneuvers—Reduced Appropriations Force Strict Economies—New Aircraft Carrier Ready in 1934.	
VII. PROSPECTS BRIGHT IN AIRSHIP FIELD.	79
"Macon" Ready to Join "Akron" in Navy Service—Transoceanic Services Hinge on Congressional Action—"Graf Zeppelin" Makes 18 Trans-Atlantic Flights in Year—"Los Angeles" Retired.	
VIII. HISTORY MAKING FLIGHTS OF 1932	89
World Altitude and Land Plane Speed Records Shattered—Five Planes Carry Twenty-two Persons on Atlantic Flights—"Graf" Makes Eighteen South Atlantic Crossings—Cross-continent Marks Cut.	

TABLE OF CONTENTS

CHAPTER	PAGE
IX. AIRPORTS: HARBORS OF THE SKY	105
New Ports Established or Existing Terminals Improved in Twenty-eight States—Aviation and Utility Interests Cooperate on Advance Planning—Newark Holds Traffic Lead—Statistics in Annual Survey.	
X. FLYING WITH THE AERIAL SERVICE OPERATOR	121
Million Passengers Carried on Short Hops and Charter Flights—Student Training is Major Activity—Photography and Mapping Projects Completed—Annual Survey Statistics Given.	
XI. AIRCRUISING IN SPORT AND BUSINESS.	129
Sport and Business Fliers Own Half of All Commercial Aircraft—Aviation Country Clubs Round Out Fourth Year—Pleasure Aircruses Gain in Popularity—New Soaring Records Set.	
XII. AERONAUTIC PROMOTION AND REGULATION	141
Department of Commerce Improves Aids to Air Navigation—Enforces New Requirement on Instrument Flying—Maintains Close Liaison with Industry—N.A.C.A., Other Bureaus, Active.	
XIII. AVIATION AND THE PRESS	149
Air Transport Aids Newspapers in Covering Year's Biggest Stories—Flying Reporters and Cameramen Used for Political Conventions, Hurricanes, Wars, Riots, etc.—Aviation Editors Busy on 117 Major Dailies.	
XIV. AERONAUTICAL LAW AND LEGISLATION	157
Special Sessions Increase Number of Aviation Bills Introduced in "Off Year"—New Licensing Acts—Gasoline Tax Laws Summarized—Chamber Continues Analysis of All Current Legislation.	
XV. EDUCATION TURNS SKYWARD	165
Aeronautics Courses Attract Thousands of Students—Enrollments Larger in Thirty-three Universities—Seventeen Award Degrees in Aeronautics—Many Faculties Approve Flight Training.	
XVI. AVIATION IN THE WESTERN HEMISPHERE	173
Air Lines Under Many Flags Serve Nations in Western World—Pan American Airways Makes Great Strides—Year's Progress Shown in Twenty-five Countries—Military Aviation Important.	
XVII. WORLD AVIATION IN 1932	191
World Air Routes Exceed 196,000 Miles—Air Lines Under Many Flags Show Progress in Review of Year in Europe, Asia, Africa and Australia—Military Planes See Action.	
PART II. MANUFACTURING AND ENGINEERING PROGRESS	
XVIII. TRENDS IN AMERICAN AIRCRAFT DESIGN.	237
New Models for 1933 Show Many Design Refinements—Military and Transport Markets Dominant—Speed, Economy and Comfort Ruling Factors—Activity for Year in Major Factories Reviewed.	
AIRCRAFT DESIGN SECTION: Passenger and Mail Transports—Private Operation and Aerial Service—Military Airplanes.	

TABLE OF CONTENTS

vii

CHAPTER	PAGE
<p>XIX. ADVANCES IN AMERICAN AIRCRAFT ENGINES.</p> <p style="padding-left: 2em;">New Engines for 1933 Incorporate Many New Refinements— Two-Row Radial Engines Introduced—Weight-Horsepower Ratio Reduced—Frontal Area Cut—Higher Grade Fuels Used— Reviews of Major Factories.</p> <p style="padding-left: 2em;">ENGINE DESIGN SECTION: Two-view Drawings of American Aircraft Engines in Production.</p>	<p>321</p>
<p>XX. RESEARCH IMPROVES COMPONENT AIRCRAFT PARTS.</p> <p style="padding-left: 2em;">Manufacturers of Accessories Effect Closer Liaison with Operators —Many Refinements of Electrical Units—Streamline Wheels Introduced—Reports from Fifty Major Companies Indicate Progress.</p>	<p>367</p>
<p>PART III. AVIATION CHRONOLOGY AND RECORDS</p>	
<p>CHRONOLOGY FOR 1932</p> <p style="padding-left: 2em;">Day-to-Day Record of Important Events in Aviation During 1932.</p>	<p>381</p>
<p>OFFICIAL WORLD AND AMERICAN AIR RECORDS</p> <p style="padding-left: 2em;">Up-to-Date Compilation of Recognized Aviation Records at Home and Abroad.</p>	<p>384</p>
<p>NATIONAL BALLOON RACE RESULTS</p>	<p>398</p>
<p>INTERNATIONAL BALLOON RACE RESULTS</p>	<p>399</p>
<p>NATIONAL AIR RACES FOR 1932 RESULTS</p>	<p>400</p>
<p>PART IV. FLYING FACTS AND FIGURES</p>	
<p>FACTS AND FIGURES ON AVIATION</p> <p style="padding-left: 2em;">More than a Score of Specially Prepared Statistical Tables Covering Every Phase of Aeronautics in the United States, with Complete Figures for 1932 Compared with Previous Years.</p>	<p>417</p>
<p>PART V. AERONAUTICAL DIRECTORY AND TRADE INDEX</p>	
<p>DIRECTORY</p> <p style="padding-left: 2em;">Up-to-Date Lists of Major Aeronautical Association Officials, Government Officers, Diplomatic and Foreign Officials, Domestic and Foreign Publications, Airports, Approved Flying Schools, etc.</p>	<p>447</p>
<p>TRADE INDEX</p> <p style="padding-left: 2em;">Aircraft and Engine Manufacturers—Manufacturers of Acces- sories, Materials and Supplies—Air Transport Operators and Refiners of Fuels and Lubricants—Exporters, Publishers and Miscellaneous.</p>	<p>484</p>
<p>INDEX</p>	<p>493</p>

PART I

The Year in the Air

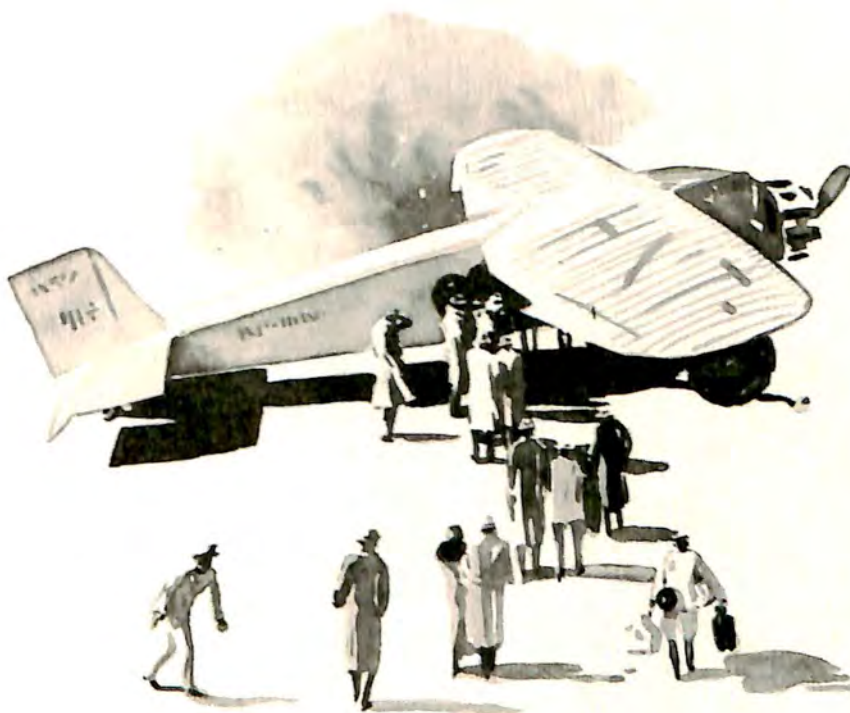

CHAPTER	PAGE
I Completing Three Decades of Flight	1
II Aviation's Index to Progress	9
III Air Lines Set Pace for Industry	17
IV "Who's Who" Among Air Travellers	49
V Air Corps: First Line of Land Defense	61
VI Preening Wings of the Flying Fleet	69
VII Prospects Bright in Airship Field	79
VIII History Making Flights of 1932	89
IX Airports: Harbors of the Sky	105
X Flying with the Aerial Service Operator	121
XI Aircruising in Sport and Business	129
XII Aeronautic Promotion and Regulation	141
XIII Aviation and the Press	149
XIV Aeronautical Law and Legislation	157
XV Education Turns Skyward	165
XVI Aviation in the Western Hemisphere	173
XVII World Aviation in 1932	191

CHAPTER I

COMPLETING THREE DECADES OF FLIGHT

Aviation Exceeds Fondest Dreams Of Wrights In First Thirty Years Of History—Depressed Economic Conditions React Against Industry—Air Transport Shows Greatest Gains—Need For National Policy Paramount

MARKED as the thirtieth year in the history of aviation, 1933 finds the aviation industry passing through a critical period of its development with three decades of remarkable achievement behind to stimulate its leaders and to justify the world's belief in its future. Few industries have enjoyed such rapid and spectacular growth during the thirty years following the discovery or invention of basic ideas upon which they are founded. None has been watched more closely nor has inspired any more fantastic predictions of its future. The pace at which progress has been made during the third decade has made it difficult even for those intimately connected with the industry to keep abreast of every branch of its activity. Most of the early predictions, which at the time appeared to be the products of fertile imagination, have been surpassed by reality itself.

Not even the ingenious Wright Brothers visualized the creation of a new mode of commercial transportation, which was destined to change man's unit for measuring distance from the mile to the minute, when they made their first successful flights just thirty years ago. Nor did they foresee the creation of a new arm of national defense, which would offer the nations of the world an important weapon on land and sea at the lowest price ever paid for national protection. It is fortunate that one of the two brother-inventors, Orville Wright, has lived to witness the growth of this new industry which had its simple beginnings at Kitty Hawk, December 17, 1903, when he became the first man in history successfully to fly a power-driven heavier-than-air machine. The memory of the other brother, Wilbur, who with Orville designed the machine, is honored by a world which for centuries searched in vain for the key to the invention of human flight. Congress has fittingly commemorated the achievement of both through the erection of a monument, which now stands on the wind-swept dune in North Carolina from which the first flight was made.

Half as old as aviation itself, "The Aircraft Year Book" has been devoted to the year-to-year story of the industry's development for fifteen years. Every effort has been made to accurately portray the year's progress in each branch of aeronautic activity throughout the world. Although this volume is complete in itself, it is designed to take a place with the fourteen successive volumes which have preceded it. The fifteen volumes unfold a story of the most important years in the industry's development, since it was not until the close of the World War that the present conception of the industry came into being.

The early volumes tell of the lessons learned as the result of creating an industry almost overnight to supply the military services with fighting aircraft, of the period following the war when surplus equipment was adapted to commercial uses, and of the first experiments of the Post Office Department and the Army in the establishment of air mail service. Those which follow unfold the story of commercial aviation's early beginnings, the success of the air mail experiment, and the growing need for a national aviation policy which resulted in recommendations of the Morrow Board, the Five Year Military Programs, the Air Commerce Act, and the turning over of air mail lines to commercial operators. Later volumes depict the spectacular flights of Lindbergh and others who fired the world with enthusiasm for aviation, and resulted in speeding the tempo of the industry's growth. The rapid development of the nation's scheduled air transport network and the advances made in engineering and manufacturing to supply reliable equipment to the military and commercial markets dominate the more recent volumes. The effect of the world-wide depression, the readjustments made necessary to counteract over-expansion and the uncertainty growing out of the lack of a continuing national aviation program are indelibly woven into the story of the years 1930 and 1931. This volume is designed to give the reader a well-rounded picture of the industry's history during 1932, and to indicate the trends of the next several years as an index to the future.

Perhaps the year's greatest advances were recorded in the field of scheduled air transport, where important traffic increases in passengers and express were made in a year marked by generally depressed business conditions. It provided one of the few bright spots of the year in the general industrial picture, and promised a rapid expansion of this new mode of transportation with the return of business from sub-normal levels. While mail traffic fell off, chiefly because of the depression coupled with a 60 per cent. rise in air mail postage rates, it is significant that the increased revenues from passengers and express made possible the furnishing of air mail service to the Post Office Department at the lowest rate in the history of the service. The Postmaster General reported that while the volume of service increased 76 per cent. during the fiscal year 1932, the cost of the



Wide World

DEDICATE WRIGHT MONUMENT

Erected by an Act of Congress, this 150 foot granite shaft at Kitty Hawk, N. C., commemorates the first successful human attempt at power-driven airplane flight in all history, achieved by the Wrights.

service to the government increased only 12 per cent. The cost to the Post Office Department of having the air mail carried by domestic contractors has been decreasing steadily, from \$1.09 per mile in 1929, 98 cents per mile in 1930, 80 cents per mile in 1931, to 53 cents per mile in 1932. It was obvious that continued support for air transport through Congressional appropriations to the Post Office Department was necessary to insure the continued advantages of the air mail service from the economic, military and social standpoints.

These savings in the operation of the gigantic network of air lines which link all sections of the country were made possible through strict policies of operating economy practiced by the contractors and through the development of even more reliable aircraft and engines, with accommodations luxurious enough to attract additional thousands of passengers. For the first time in the history of air transport, more than a half million passengers were carried on America's scheduled air lines during a single year. Since it was a known fact of air transport economics that the cost per mile of operations could be cut from 25 to 45 per cent. by the doubling of schedules on a route, further savings were promised in the future when the stringency of the present economic situation might be loosened sufficiently to provide more frequent service over the major routes.

No less important from the standpoint of international trade was the advance made in the welding together of all American scheduled air lines outside the continental limits of the United States under the administration of a single company, with a unified policy of operation. It is apparent that aviation is certain to have as great an effect upon the lives of nations as the automobile has had upon family life and community relationships. Because of the important economic, military, and social advantages of the vast network of international air lines developed under the sponsorship of the Post Office Department, continued Congressional appropriations for foreign air mail service are considered vital to the protection of the investment already made.

During a period when the market for commercial aircraft is at low ebb, the importance of appropriations for military aircraft is paramount to insure the holding of manufacturing and engineering facilities intact and in readiness for immediate expansion in case of a national emergency. The past year has been marked by the dominant part played by orders for military aircraft, despite the fact that such orders were smaller than in previous years. Without such military orders, it is certain that the highly trained staffs of specialists assembled by several important manufacturing units as well as the plant facilities themselves would have been lost.

A strong civil aviation structure is a primary national defense asset. Civil aeronautics occupies a particularly important position in any national defense consideration, because of its unique ability to supply immediately

for national defense purposes both a key transportation service and a key manufacturing organization. The air lines' maintenance bases, situated strategically throughout the country, constitute a military asset of extremely impressive importance, yet they are doing a peacetime service of great economic value and are without direct expense to the military establishment. The indispensable nature of the hundreds of commercial and municipal airports throughout the country, part of the civil aviation structure, and of the system of airways developed by the Aeronautics Branch of the Department



FIFTEEN HOURS AND EIGHTEEN MINUTES

Amelia Earhart Putnam among admirers near Londonderry, Ireland, the morning after her solo trans-Atlantic flight.

of Commerce was demonstrated strikingly during the Air Corps' division maneuvers in 1931.

It is no secret in the aviation industry that the lack of a continuing national aviation policy, which would permit advance planning by manufacturing and operating units alike, has caused a disturbing feeling of uncertainty during the last two or three years. The period indicated by Congress for the completion of the Five Year Military Programs is past, with the Army's program still incomplete because of lack of necessary appropriations and no decision made upon future policy for the next ten years as recommended by the Morrow Board and the Select Committee of Inquiry into operations of the United States Air Services. Similarly, the

air transport lines have been hampered in making advance plans because no definite policy for appropriations over a period of years has been decided upon by Congress. In the field of international airship transport, the building of a fleet of giant super-airships to carry passengers, mail and express over the Atlantic and Pacific awaits the approval of a bill before Congress giving to air carriers the same rights and privileges accorded surface carriers on the sea. The program of the Department of Commerce for developing a system of airways with aids to air navigation similar to those provided by the government to water navigation has, likewise, been

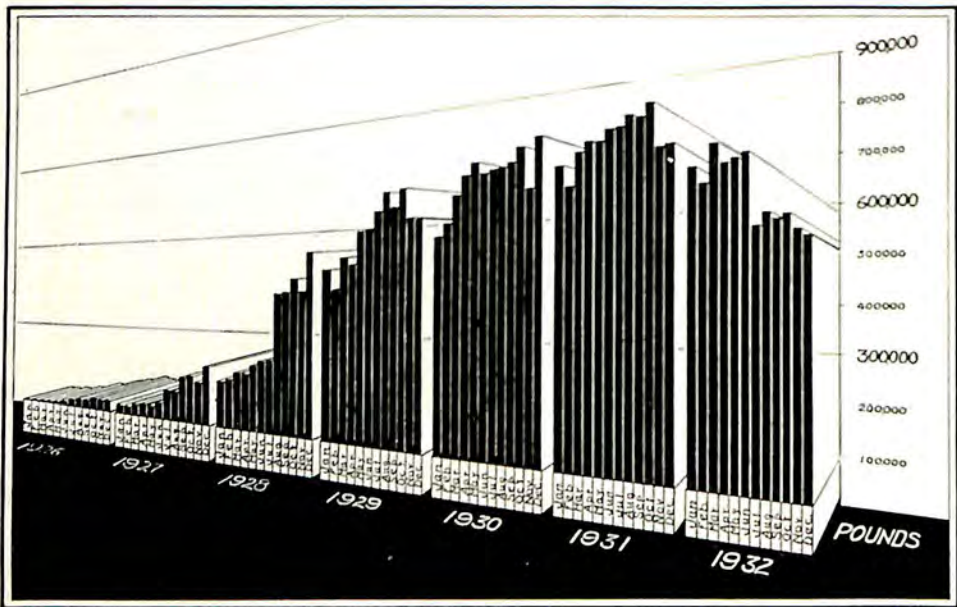

AIR MAIL CARRIED BY SCHEDULED AMERICAN AIR TRANSPORT LINES

curtailed through decreased appropriations. All of these projects would insure employment to highly skilled men whose services should be retained to aid in building the aviation industry as an element essential to the national defense and necessary to the fulfillment of the economic and social needs of the country during the next decade.

The progress made during the past year in the manufacturing and engineering of new aircraft and engines, the operation of scheduled air transport services, the training of an adequate reserve of pilots and mechanics, the construction and operation of airports, and the continuation of a program of research and engineering to anticipate the needs of the private and commercial markets of fatter years in the future stands as a real tribute to the leaders directing the many-sided activity of this new industry's devel-

opment. Their faith in the future and their desire to fulfill the military and economic needs of the country deserve the adoption of a continuing national aviation policy, which would supply the industry with a minimum of assured activity over a period of years to reasonably and conservatively develop the industry's resources.

The foundation for the government's policy on aviation, both in its civil and military aspects, was laid at the close of the World War during the Wilson Administration. At that time President Roosevelt was Assistant Secretary of the Navy in the Wilson Cabinet. During the years of his

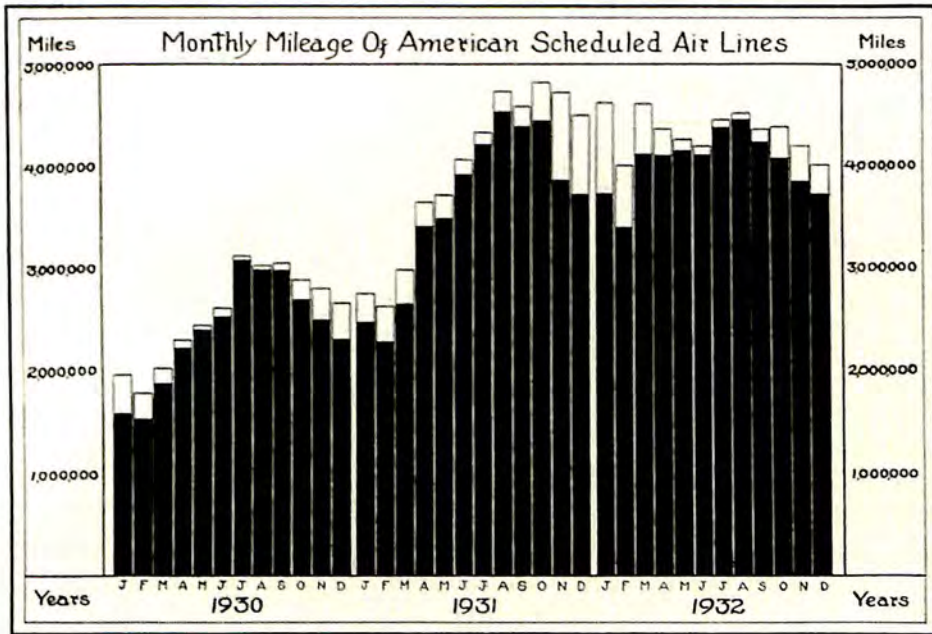

Secretaryship and later as Governor of the State of New York, Franklin D. Roosevelt was in constant touch with the development of the industry as an important national institution, and his entire family became enthusiastic patrons of air transport. The groundwork laid by the Wilson Administration was built upon by the three Republican administrations which followed under the leadership of Presidents Harding, Coolidge and Hoover. Throughout these years, aviation received the support of leaders in the Democratic as well as the Republican party along strictly non-partisan lines.

With a flying President in the White House, the industry looks with renewed hope for leadership from a man fully cognizant of the rapid strides already made in commercial and military aviation, and capable of supplying the force, through his assured support from both houses of Con-

gress, for the carrying out of a continuing national aviation program. Such an adopted policy would save millions upon millions of dollars during the next decade. Aviation has the support of Democratic leaders in both houses of Congress, many of whom have used air transport frequently during the past year and recognize fully its important place in the national scheme of transportation and defense. Because aviation's support since the earliest days of the new industry never has been drawn along strictly party lines, leaders in both parties can be counted upon to back the carrying out of a continuing national program designed to permit planning years in advance instead of the uncertain policy of making appropriations from year to year without a definite program.

The chapters which follow should provide an interesting review of the year's activity in every phase of aeronautics. Part I is devoted to the story of "the year in the air," not only in the United States, but throughout the world. Part II embraces a complete work in itself on every phase of aircraft engineering and manufacturing, with three-view engineering drawings of major aircraft and engines together with performance data and specifications. Part III is a handy aviation chronology for 1932, with complete world and American aviation records, and the results of all important air contests during the year. Part IV is a statistical handbook containing accurate and up-to-date facts and figures in comparative tables on every phase of aviation. Part V is an aeronautical directory and trade index, with up-to-date lists of aeronautical association officials, government officers, diplomatic officials, domestic and foreign publications, airports and airport managers, approved flying schools, aviation editors, manufacturers, operators, and similar information. In effect, "The Aircraft Year Book for 1933" is five books in one, so compiled that the reader will find it easy to use for future reference on any subject connected with aviation. A complete index is provided in the back of this volume.

CHAPTER II

AVIATION'S INDEX TO PROGRESS

Passenger and Express Traffic On Scheduled Air Lines Grows—Higher
Postage Rates Cut Mail Volume—Private Flying and Aerial Service
Hit By Depression—Production Off—Army, Navy, Other
Statistics

WHILE statistics do not furnish all of the nice tones, shades and colorings necessary to accurately portray an industry's true picture of progress, they do supply the sharp basic outlines which offer a ready index to the strides made in each field of development. Appreciative of the need for the accurate collection, compilation, and interpretation of statistics in all modern industries, the Aeronautical Chamber of Commerce of America as the national trade association of the aircraft industry maintains an active division devoted to the day-to-day task of furnishing its members with accurate statistics on every branch of aviation activity.

Rather than burden the swift moving story of the year's activities in aeronautics as described in succeeding chapters with heavy statistical analyses, it has been considered better to review briefly here the broad outlines drawn from the year's statistics and to place the detailed tables in form for ready reference in another section of this volume, Part IV, "Flying Facts and Figures." Succeeding chapters will use statistics sparingly, and only when they are absolutely necessary to the discussion.

All aircraft under the American flag, including planes in civilian, commercial and governmental operation, flew a grand total of 194,133,858 miles in 1932. It was logical to expect this figure to be under the total of 218,890,503 miles flown in 1931, because of the sharp decreases in private flying, aerial service operations, and governmental operations; all of which could not be offset by the gains made in scheduled air transport. It is interesting to note, however, that an industry had built up such an auspicious total mileage within the first three decades of history in the nation of its birth. Civilian and commercial flying during 1932 accounted for 123,641,238 miles of the grand total, while government operations, including the Army, Navy, Marine Corps, Coast Guard and Department of Commerce, totaled 70,492,620 miles.

America's scheduled air transport lines, with histories dating back only a half dozen years, showed gains during 1932 in every department of traffic and operations, except mail. The decrease in mail traffic resulted chiefly from a 60 per cent. increase in air mail postage rates at a time when business conditions were depressed. Express and passenger operations accounted for the year's principal gains. With 655 transport planes in service, the American lines reporting to the Aeronautical Chamber of Commerce of America carried 504,575 passengers, 1,324,428 pounds of express, and 7,658,332 pounds of mail a total of 48,344,358 miles during 1932. These

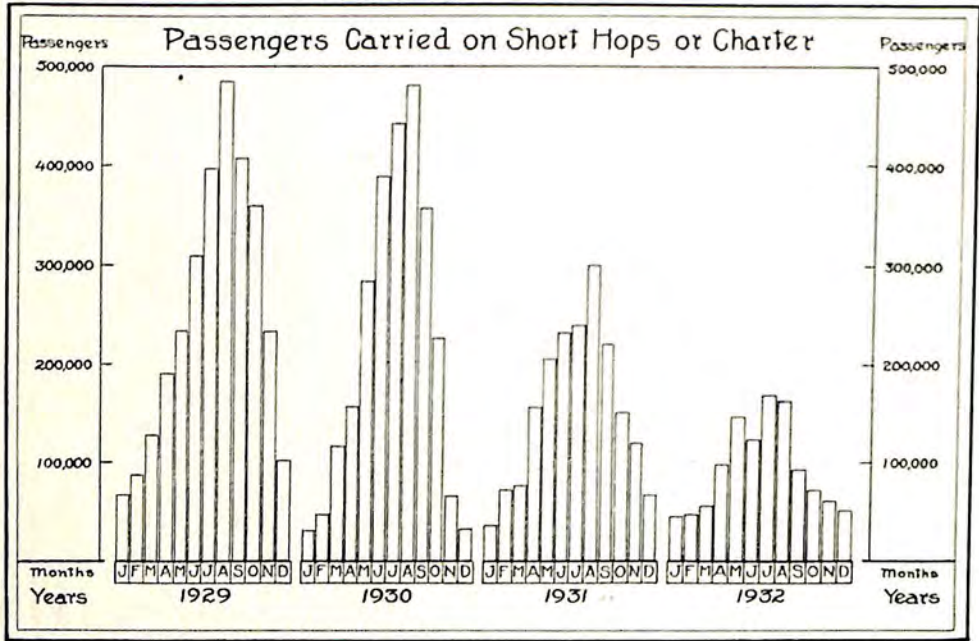

figures could be compared with those for 1931, the previous peak year, when 457,753 passengers, 885,164 pounds of express, and 9,351,195 pounds of mail were carried a total of 43,395,478 miles. Passenger-miles increased from 116,232,153 in 1931 to 143,169,682 in 1932.

Comparing 1932 with the previous peak year, 1931, miles flown increased 11.4 per cent., passengers increased 10.02 per cent., express poundage jumped up 49.6 per cent., and passenger-miles increased 23.1 per cent., while mail poundage showed a decrease of 18.1 per cent. Detailed tables of statistics on scheduled air line operations from 1926 to 1932, inclusive, and monthly during 1932 will be found in form for quick reference in Part IV.

Aerial service operations in terms of miles flown in all types of flying,

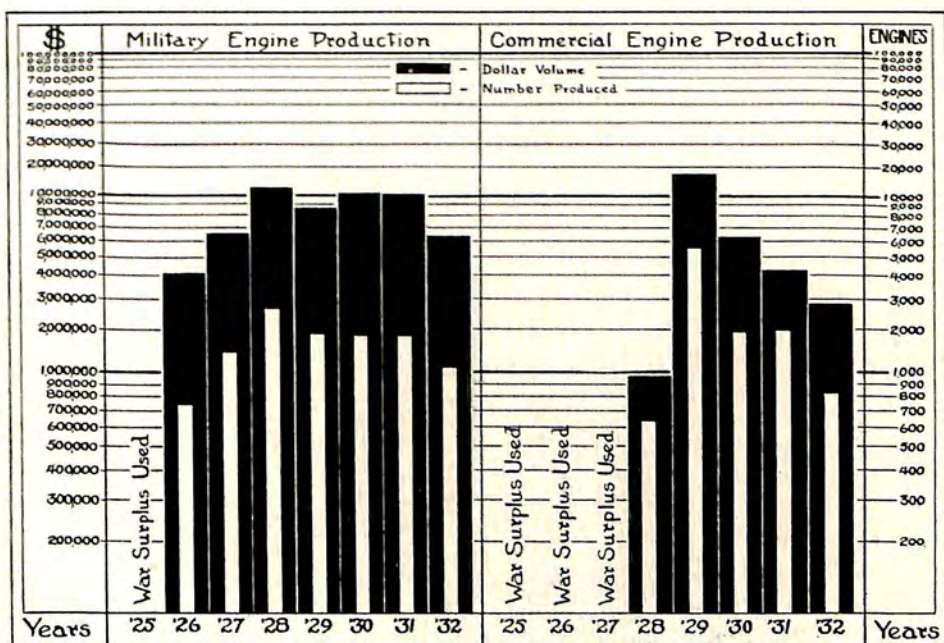
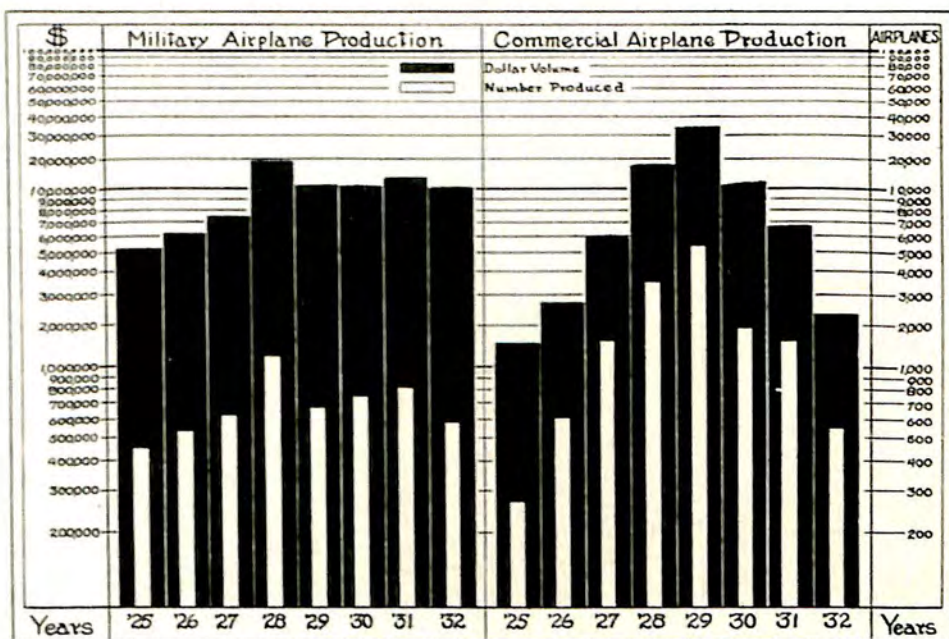

ranging from crop dusting to aerial photography and short passenger hopping, fell off 29.8 per cent. during 1932, according to the statistics compiled by the Aeronautical Chamber of Commerce in its seventh annual study of operations in the aerial service field. Statistical estimates based on typical reports and computed to include 280 operators in business in 1932 showed that 1,979 planes in service flew 50,296,880 miles in pursuit of their diverse tasks, which included the carrying of 1,118,587 passengers on charter flights or short hops. These figures could be compared readily with those for 1931 when 352 operators in business with 2,818 planes in service flew a

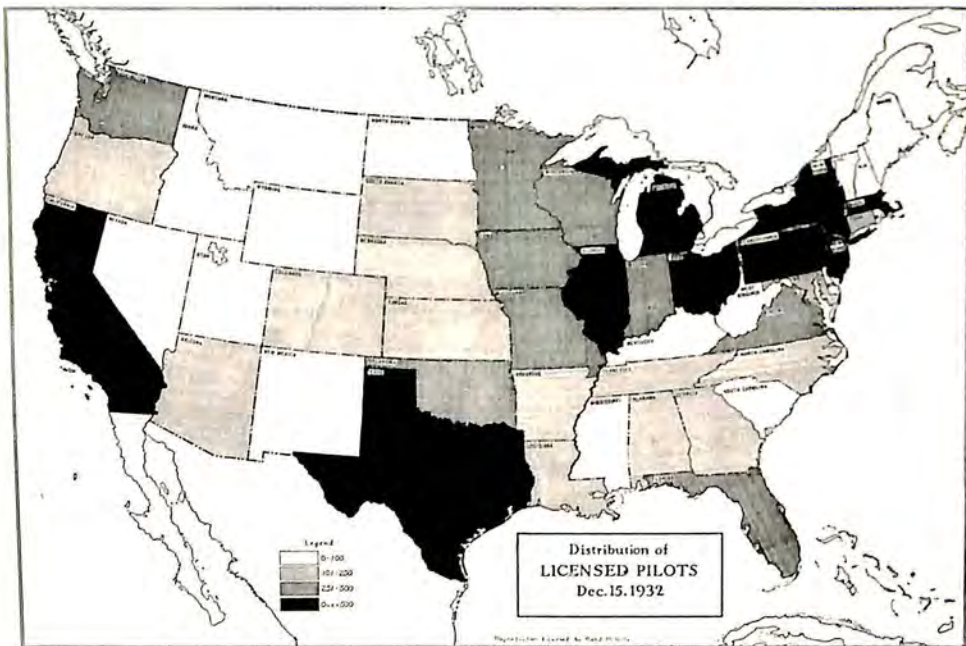

total of 71,582,750 miles, and carried 1,875,992 passengers on short hops or charter flights. The peak year in the aerial service field, as will be seen from a study of the statistical table in Part IV, was 1929 when 800 operators in business used 7,695 planes to fly a total of 104,336,560 miles and carried a record number of 2,995,530 passengers on short hops and charter flights.

Private and industrial flying, likewise, was hit hard by the general business depression, resulting in a sharp cut in the volume of flying logged in this field during 1932. Because of the very character of the activity, it was practically impossible to obtain exact statistics on the miles flown by individuals and corporations for business and pleasure. However, the Aeronautical Chamber of Commerce estimated that the 5,128 planes in the hands

of private owners flew 25,000,000 miles during 1932. This represented a drop of 5,000,000 miles from 1931 figures and 15,000,000 miles from the peak year of 1930. The United States continued to lead the world in private flying as will be seen from the discussion in later chapters dealing with "Aircruising in Sport and Business" and "World Aviation in 1932."

Government operations, affected directly by reduced appropriations which cut the number of flying hours allowed Army, Navy and Marine Corps pilots, showed a decrease during 1932, although planes of the United States Coast Guard and the Department of Commerce were more active

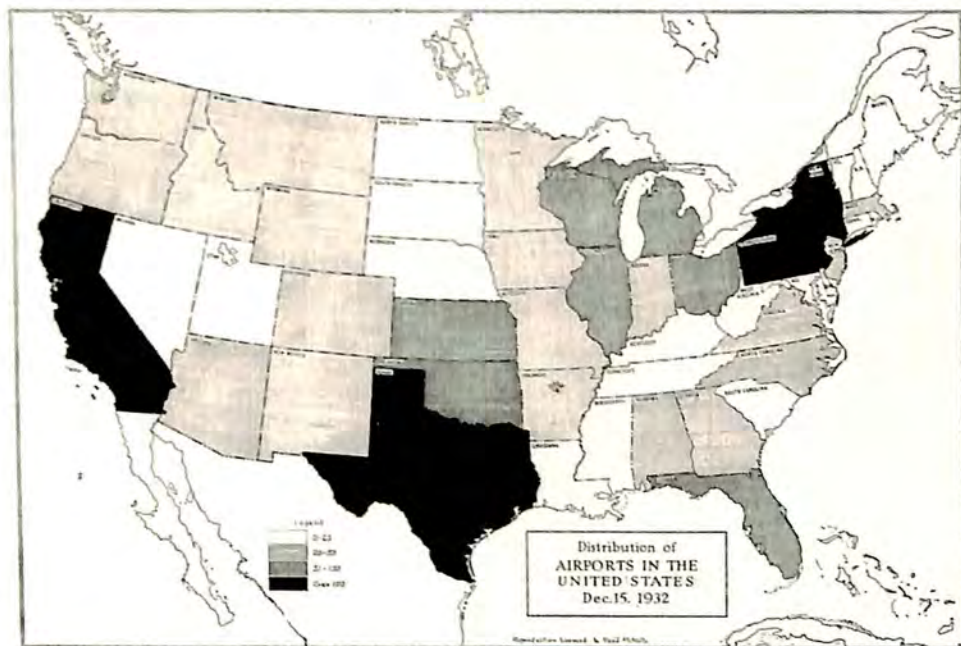

than in the preceding year. The Army Air Corps and National Guard flew a total of 42,914,655 miles in 1932, a decline of 2.5 per cent. from 1931 figures. The Navy and Marine Corps flew a total of 26,508,715 miles in 1932, a drop of 8.3 per cent. from 1931 log figures. The year 1931 was the peak for all branches of the military services. The Coast Guard piled up a total of 93,750 miles in 1932, the largest in its history, and planned to extend and expand its air branch in 1933. The Department of Commerce's planes logged a total of 975,500 miles during 1932 as compared with 969,000 miles in 1931, and 1,427,000 miles in 1930, the peak year. Complete statistics on governmental operations for seven years will be found in Part IV.

Aircraft production in 1932, including both military and commercial

aircraft, fell off more than 50 per cent. in total units and 35.2 per cent. in total value. These sharp declines from 1931 figures, which were lower than 1928, 1929 or 1930, resulted from cuts in military appropriations for aircraft and in the collapse of the commercial market, except for purchases of equipment for the air transport lines. Fifty new transports, produced during 1932, were bought by the air lines to replace old equipment or make possible additional services. About 45 per cent. of all aircraft produced during 1932 was absorbed by the military services, and military production accounted for nearly 80 per cent. of the total value of aircraft produced.

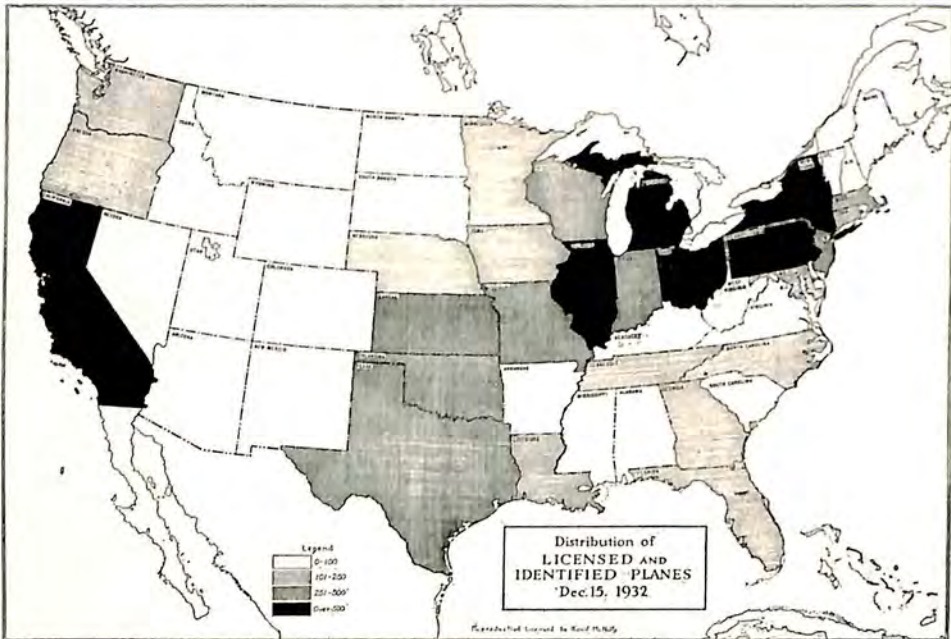

Commercial aircraft produced in 1932 totaled 549 units, a 65 per cent. drop from the previous year. Their total value was \$2,337,899, representing a 64.9 per cent. decrease. Commercial aircraft sales totaled 748 units with a total value of \$2,807,775, representing decreases from 1931 figures of 54.9 and 63.3 per cent. respectively. The fact that inventories had virtually been depleted was encouraging, because 1933 production would immediately react to the slightest uptrend in conditions.

Military aircraft produced in 1932 totaled 593 units, 27 per cent. less than 1931, with a total value of \$10,389,316, which was 19.9 per cent. less than 1931 figures. Military aircraft units delivered during 1932 totaled 618 with a total value of \$10,791,343, representing decreases from 1931 figures of 24 and 18.3 per cent. respectively.

Engine manufacturing, considering both commercial and military power units together, fell off in 1932 in about the same proportion as aircraft production. The total value of all engines produced in 1932 declined 36.5 per cent. from 1931 figures, while the value of all engines sold fell off 40 per cent. Reductions in military appropriations and the decline of the low-horsepower commercial field, which accounted for a large share of the units manufactured in 1931, brought about the decreases in 1932 production.

Commercial engines manufactured in 1932 totaled 813 with a value of

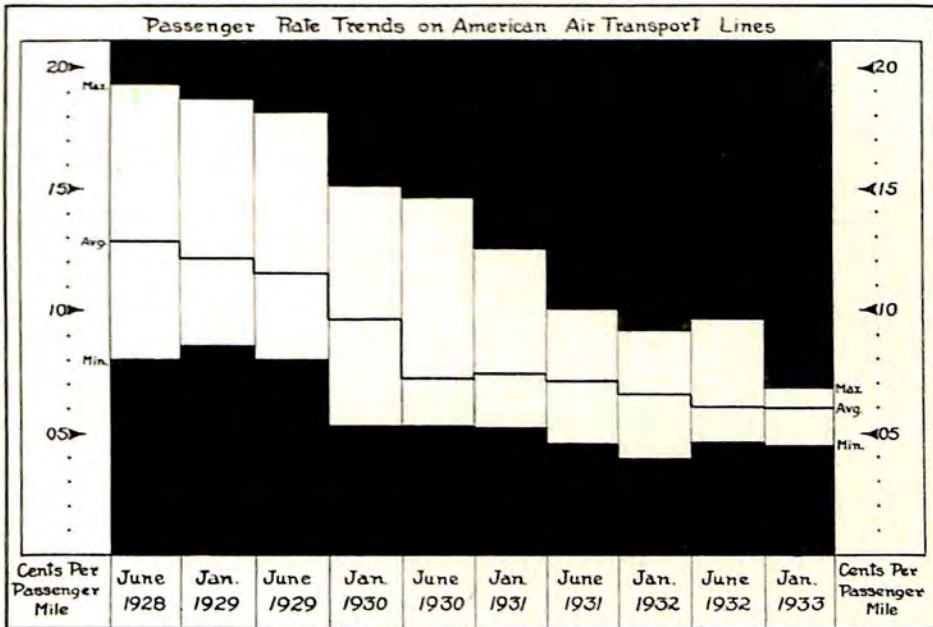

\$2,898,371, a decline of 58.8 and 30.8 per cent. respectively. Commercial engines sold totaled 852 units with a value of \$2,778,876, representing decreases from 1931 figures of 57.6 and 39.3 per cent. respectively. Military production was far more important. Military engines totaled 1,085 units manufactured in 1932 with a total value of \$6,370,678, or a decrease of 39.7 per cent. in units and 38.8 per cent. in dollar volume. Military engines delivered in 1932 totaled 1,090 units with a total value of \$6,376,451, representing declines from 1931 figures of 40 and 40.3 per cent. respectively.

As will be seen from the discussion in Part II of this volume, "Manufacturing and Engineering Progress," there was a definite trend during 1932 toward engines of larger horsepower for transport and military use. The production and sales tables in Part IV, broken down according to

horsepower classes, bear out this trend. The tightening up of the market for light commercial planes for private use accounted for the sharp decreases in production of low horsepower engines, which were predominant in the 1931 market.

In common with the experience of manufacturers of conventional aircraft for private and commercial flying, the producers of autogiros found their market in 1932 somewhat smaller than in 1931, the first year in which the autogiro was offered to the commercial market. Thirty-nine were produced and 34 sold in 1932 as compared with 51 manufactured and 46 sold in 1931. The market for seaplanes and amphibians also remained to be developed to its fullest promise.

Aeronautical exports to countries throughout the world in 1932 stood as a tribute to the quality of American aircraft and engines, especially at a time when nations were experiencing drastic reductions in their export trade. Aeronautic exports in 1932 had a total value of \$7,710,259 as compared with \$4,809,440 in 1931. Aircraft units totaling 273 were exported from the United States in 1932 as compared with 140 units in 1931. The value of aircraft exports in 1932 totaled \$4,539,719, which could be compared with a total value of \$1,812,827 in 1931. Engines exported totaled 2,175 units with a total value of \$1,462,244, as compared with 318 engines valued at \$1,474,785 in 1931. Detailed analyses of the export market, including information on the countries to which exports were made, will be found in a specially prepared table in Part IV for this volume.

The Aeronautics Branch of the Department of Commerce maintains an elaborate organization for the compilation and interpretation of aircraft accident statistics. Unfortunately, statistics for the last half of the year can never be included in this volume because the work of collection and interpretation of the information is so slow and tedious as to necessitate several months' delay in the preparation of each report. However, detailed tables analyzing aircraft accidents in air transport and miscellaneous flying are provided in Part IV of this volume to permit comparisons of several years by six month periods. Complete statistics for the first six months of 1932 are included, with detailed information on the causes of all accidents.

As was stated at the outset of this chapter, it is difficult to give a complete picture of an industry's progress through the presentation of its vital statistics. However, it is believed that with the statistical background herein furnished, it should be possible to obtain a quicker grasp of the significant advances in the fields of engineering, research and operation described in the chapters which follow.

CHAPTER III

AIR LINES SET PACE FOR INDUSTRY

Technical Advances Improve Operating Efficiency—Many Faster And More Frequent Services Inaugurated—New Air Express Hookups Boost Traffic—High Air Mail Rates Cut Poundage

WITH progress recorded in every branch of air line activity, the scheduled air transportation system of the United States set a rapid pace for all divisions of the aeronautical industry in 1932. As we have learned from the statistical analyses in the preceding chapter, American air lines set new traffic records in mileage flown, mileage of routes operated, passengers transported, and express carried. The year's only decline was recorded in mail traffic, due to a combination of generally depressed economic conditions and a 60 per cent. rise in domestic air mail rates.

The decrease in air mail poundage, although vital to the air lines in their development, failed to seriously mar the general picture of progress made in scheduled air transport to provide faster, more frequent and more convenient schedules for passengers, mail and express. As we shall see from a study of aviation activity in every country on the face of the globe, described in two later chapters, no nation could boast of an air line network equal to that under the American flag.

Several major American operators could point to traffic statistics for their individual companies which were greater than the combined operations of all air lines under the flag of some foreign nations. United Air Lines held first rank among American operators in total number of miles flown during the year, piling up an all-time record of more than 14,000,000 miles. United Air Lines and American Airways shared honors in the passenger field, the former carrying 96,567 persons, and the latter 90,086. United Air Lines took first rank as a mail operator in volume of traffic, transporting 3,337,085 pounds of air mail. Transcontinental and Western Air could point to its record of more than 95,000 pounds of express flown during the year, while Pan American Airways with its 25,000 miles of routes extending from Southern Argentina to Alaska was the premier American line from the standpoint of route mileage. Since all of Pan

American's routes were outside the continental limits of the United States, American Airways' system of 9,570 miles within the United States took first rank among domestic operators in route mileage. The vast international network of air lines being operated by Pan American Airways will be described in a later chapter, "Aviation in the Western Hemisphere."

As will be seen from a study of activities in other countries throughout the world, many air lines under foreign flags discontinue most of their services during the winter months. However, there was a marked trend toward following the American policy of operating all routes throughout the year. American air lines were flying 140,549 miles daily over 48,775 miles of routes in 1932. Unlike operations in most foreign countries, where there was little or no night flying, more than 43 per cent. of the mileage flown daily in the United States was being done between dusk and dawn. Night flying and all-year operations accounted for a major share of the success of the American lines in providing a dependable system of transportation that offered marked advantages over the fastest surface media.

The expansion of night flying operations and the extension of night services to include passengers resulted in a general speeding up of schedules for all classes of traffic during the year. With the inauguration of overnight air passenger service August 1 between America's two largest cities, New York and Chicago, United Air Lines completed the final link in the first "one business day" air passenger service between the Atlantic and the Pacific. Passengers leaving either seaboard late at night arrived on the opposite seaboard at the breakfast hour of the second morning, resulting in the loss of only one business day to the traveller. With two-thirds of the mileage flown at night in tri-motored transports, the flying time of United's coast-to-coast service was twenty-six and three-quarter hours eastbound, and thirty-one hours westbound over the 2,763 mile transcontinental route.

Transcontinental and Western Air inaugurated the fastest air passenger schedules ever operated between the Atlantic and Pacific Coasts November 5, when overnight passenger service between New York and Kansas City was started. The fast through service cut existing schedules between New York and Los Angeles over the 2,567 mile route to 24 hours and 42 minutes eastbound and 28 hours and 43 minutes westbound, elapsed time.

While the coast-to-coast schedules always attract more national attention than other important inter-city services because the travelling public has measured the progress of transportation media from the days of the prairie schooner and pony express in terms of the time required to span the continent, scores of important schedule changes were made during the year by almost every operator.

Washington and New York, 205 air-miles apart, were within 80 minutes of each other. Chicago and Dallas, with nearly 1,000 miles between them,



AIR EXPRESS POUNDAGE GROWS

Air Express Division of Railway Express Agency, under new contract with four air lines, loading shipment on Hornet-powered Boeing transport.

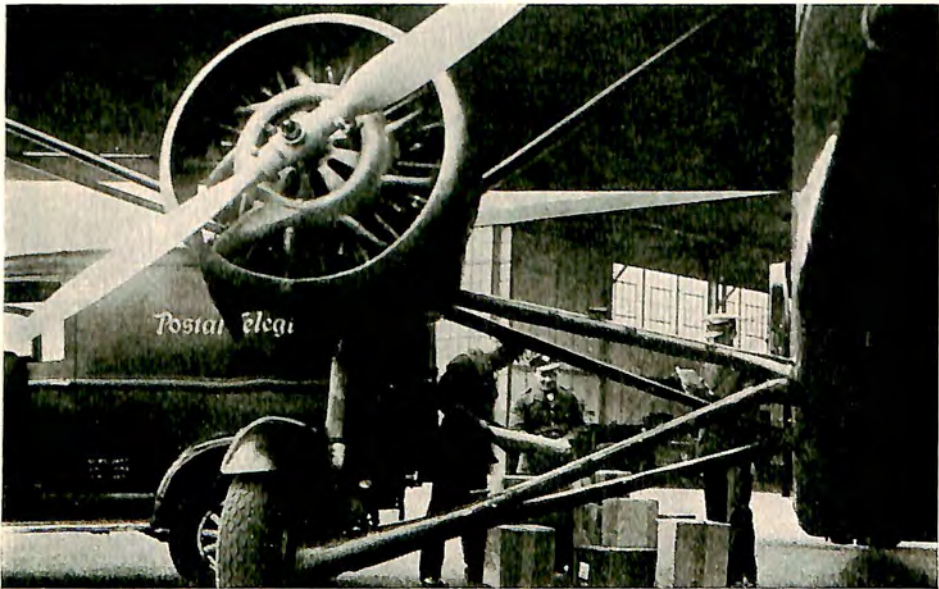

INAUGURATING NEW EXPRESS SERVICE

General Air Express, embracing seven lines with Postal Telegraph pick-up service, loads cargo on Lycoming-powered Stinson airliner.

were linked in an overnight flight. Cleveland and Detroit, several hours apart by surface travel around the shore of Lake Erie, were within 55 minutes of each other. Atlanta and Dallas, 783 miles apart, were linked by an easy daylight flight. Los Angeles and Dallas, with 1,350 miles between them, were served by an overnight hop. New York and Jacksonville, 871 miles apart, had only a beautiful daylight flight down the Atlantic seaboard separating them. The modern unit for measuring distance was not "miles" but "minutes."

To provide these faster schedules and aid traffic departments in the building of business volume, the operations and maintenance departments were called upon for an unusually high standard of excellence in their task of insuring dependable operation on closely-knit schedules. Many lines purchased new and faster planes during the year, or aided in designing ships to meet their specifications for delivery early in 1933. The addition of a fleet of Hornet-powered Consolidated Fleetsters and Wasp-powered Northrop Alphas aided Transcontinental and Western Air in its effort to speed up schedules. United Air Lines prepared to cut further its schedule for the coast-to-coast flight, as well as improve service on other divisions, through the ordering of 60 new twin-engined low-wing all-metal transports developed by an allied company, Boeing Airplane Company. The first of this fleet of high-speed transports were to go into service in 1933. Similarly, Eastern Air Transport placed an order for five new twin-engined high-speed Condors of a new design developed by the Curtiss-Wright Airplane Company, scheduled for service in 1933. Transamerican Airlines Corporation also announced its order of four Condors to be placed on the lines in 1933. American Airways added a fleet of Lycoming-powered Stinson U tri-motored transports to speed up service on several of its routes during 1932, and was planning new purchases of faster equipment in 1933. In fact, almost every operator purchased or placed orders for new transport planes during 1932, or made detailed changes in present equipment to insure faster speeds and greater comfort for passengers.

One of the most significant trends in the development of new equipment for the air lines was the closer liaison between the operators and the manufacturers on specifications for new designs. The manufacturer was thus enabled to develop planes incorporating such detailed features of design as the operator had learned through experience would cut maintenance costs, insure more dependable operation, and provide greater comfort for the passenger. It meant the development of planes which could be placed directly into service by the operator without rebuilding or altering the design to meet his specific needs, thus reducing operations costs although the first unit cost of the product sometimes was raised. The new designs developed for 1933 operations are fully described in Part II of this volume, "Manufacturing and Engineering Progress."

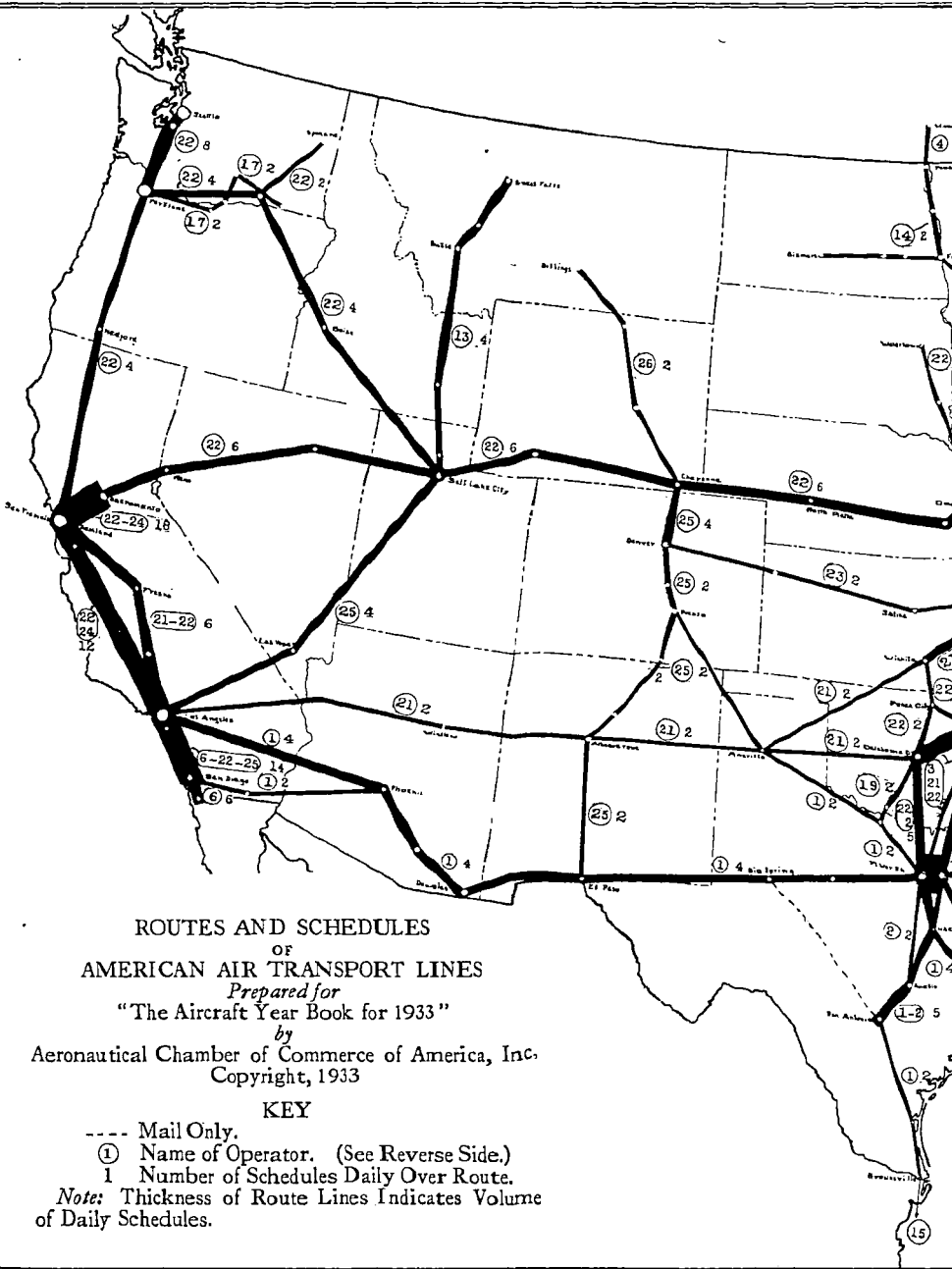

ROUTES AND SCHEDULES
OF
AMERICAN AIR TRANSPORT LINES

Prepared for
"The Aircraft Year Book for 1933"

by
Aeronautical Chamber of Commerce of America, Inc.
Copyright, 1933

KEY

----- Mail Only.

① Name of Operator. (See Reverse Side.)

I Number of Schedules Daily Over Route.

Note: Thickness of Route Lines Indicates Volume of Daily Schedules.

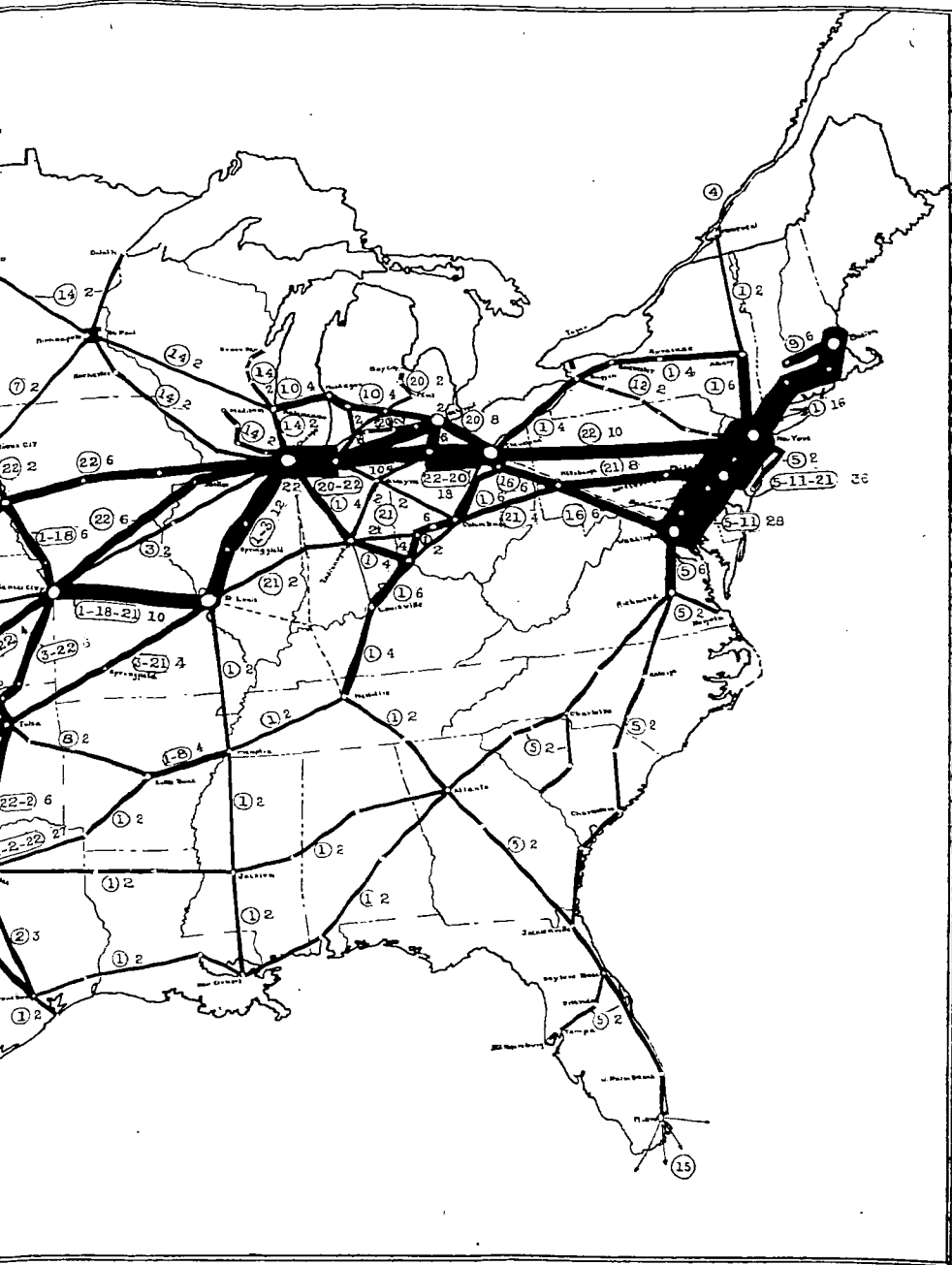

Closely allied with this promising trend toward an interchange of information between operators and manufacturers on details of plane design was the activity of the operators through which the operations and maintenance departments of the major air lines carried on a constant exchange of data on current experiences. This work was carried on through the Operations, Maintenance, and Radio Committees of the Air Transport Section of the Aeronautical Chamber of Commerce of America. Company experts in each of these fields met at appointed intervals to crystallize their views on important subjects, often passing on direct recommendations to



HEADED FOR BOSTON

On frequent schedules of American Airways, Inc., these new Lycoming-powered Stinson tri-motor transports link New York and Boston.

aircraft, engine and accessory manufacturers. These periodic discussions were supplemented through a constant interchange of information through illustrated reports submitted to the Chamber by member lines and redistributed for the information of all other member air transport companies.

Several of these studies were concerned with the successful solution of problems resulting from the increased emphasis placed upon instrument flying and radio communication, both of which accounted for a large share of the technical progress made in assuring more dependable operations. While several of the major operators had devoted considerable time and money for training their pilots in the art of flying solely by the aid of instruments and radio during 1931, all operators turned their attention

toward this subject in 1932 as a result of a new Department of Commerce regulation requiring all pilots to pass a special test for an instrument flying rating. This new requirement is described in a later chapter, "Aeronautic Promotion and Regulation." All air line pilots were required to qualify for the rating by January 1, 1933. The effect of the rating is to insure the air line operator and travelling public alike that every pilot flying passengers on a scheduled air line is capable of flying solely by the use of instruments, with the aid of radio, both the guiding beam of the radio beacon and two-way communication with the ground. Pilots were tested by flying in a hooded cockpit without sight of the natural horizon or ground to aid them, and with an inspector to check their maneuvers. The new regulation and increased emphasis on the importance of instrument flying did not mean that the operators or the Department would sanction flights in the face of dangerous weather conditions, but it was expected that greater operating efficiency and safer operation would be a direct result. Standardization of the location of instruments on each panel was a necessary step in the successful solution of this problem which was aided through an interchange of data between the major lines through the Air Transport Section of the Chamber.

Progress in the development of instruments, radio and other devices, such as the one to keep ice from forming on the wings of transport planes, will be described in later chapters in Part II of this volume, "Manufacturing and Engineering Progress." Suffice it to say that the manufacturer and operator were cooperating closely in the successful solution of those problems allied with greater safety and comfort for the passenger. Attention was being given in new designs to such problems as noise, through a careful study of reducing them at their source, and to the perfection of more comfortable chairs, better heating and ventilation, and adequate lighting. The air line passenger of 1933 was assured the highest standard of comfort and convenience that could be maintained, with nothing left undone.

The maintenance and overhaul repair bases of the lines were models for meticulous care and efficiency which many older transportation systems could well afford to copy. Air line traffic departments had learned that the prospective passenger who showed the slightest signs of timidity could be sold through a visit to one of the company's maintenance bases, and some of them arranged occasional trips through their shops to permit the passenger to learn for himself how the modern air line maintains its equipment, how 48 man-hours are spent in inspecting each ship after 25 flying hours, with complete overhauls of planes and engines at appointed intervals, and careful inspection at bases along the line as well as through detailed daily reports from each pilot.

The new Transcontinental and Western Air maintenance base and operating headquarters, built at a cost of \$300,000 and opened during 1932



LINKING PLANE AND GROUND

United Air Lines' radio operators talk to planes in flight from thirty-six ground stations along coast-to-coast system.

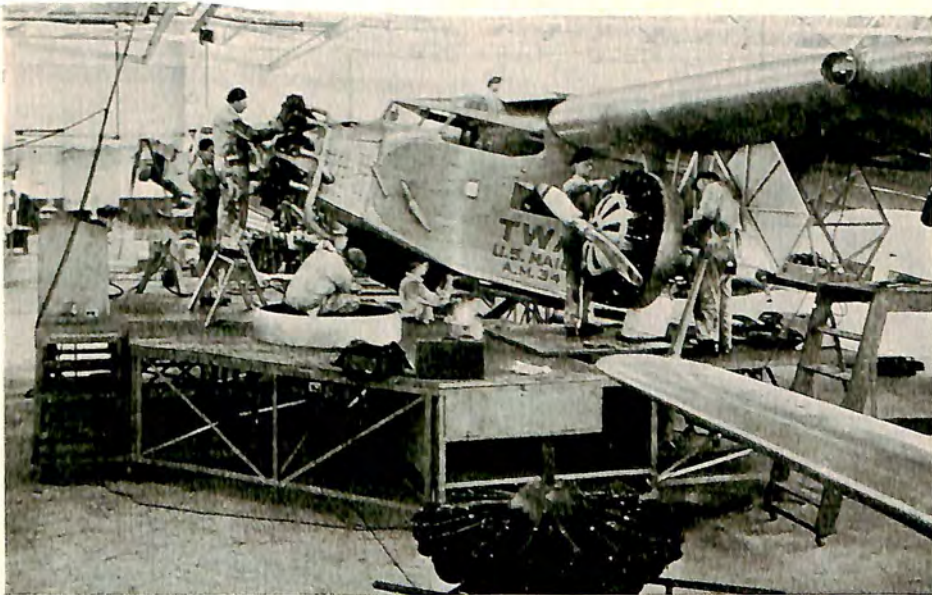

MAKING ROUTINE INSPECTION

Six men spend 48 man hours in routine inspection of each TWA multi-motored transport after 25 hours of flight.

on the Kansas City Municipal Airport, was typical of the trend toward consolidating overhaul and repair work at a central point, or at least at a strategic division station. The new building, 400 feet long and 300 feet wide of brick and steel construction, provided a hangar capable of housing 20 large multi-motored planes, machine shops, engine testing laboratories, metal shops, instrument and radio rooms, a central dispatch room, weather bureau, and general offices of the company's various departments. Eastern Air Transport made substantial additions to its central base at Atlanta to provide complete facilities for aircraft and engine overhauls at one point on the system. Pan American Airways centralized its maintenance and overhaul work at Miami by converting its land airport, Pan American Airport, into a gigantic maintenance base for all types of equipment on all of its divisions. United Air Lines made many improvements in its modern divisional bases at Chicago, Cheyenne and Portland. American Airways consolidated a major portion of its maintenance work at a central shop in St. Louis, although some work was still done at divisional bases. Trans-american Airlines Corporation centralized its overhaul and maintenance work at Pontiac, Mich. Other lines continued the operation of their bases, selected chiefly because of their central location: Ludington's was at Washington; National Parks Airways' at Butte, Mont.; Western Air Express' at Burbank, Cal.; and Pennsylvania Airlines' at Pittsburgh.

The improvement of terminal facilities, intermediate landing fields, and aids to air navigation along the airways are of primary importance to the operating departments of the air lines, and many important advances were made in this field during the year. The air lines themselves invested in new passenger terminals at many important points along the airways. Airports maintained through municipal and private initiative likewise were improved to care for the needs of increased traffic. These developments will be fully described in a later chapter, "Airports: Harbors of the Sky." The work of the federal government in maintaining the airways for both air transport and private flying, just as the government provides harbors, lighthouses and other aids to marine shipping, also will be described in a later chapter, "Aeronautic Promotion and Regulation."

Ground transportation facilities between airports and the central business sections of cities underwent important changes during the year to provide the air passenger with the utmost in speedy service. The air lines either maintained as a part of their organization or contracted for fleets of high speed limousines in most major traffic centers to aid in the complete solution of this problem. An outstanding example of how all modern engineering achievements were linked to insure rapid transportation between airport and city was provided in the high speed ground transport system afforded New York City and the air terminal near Newark. Twelve to sixteen cylinder limousines of the latest design were used from central



ITS ANCESTOR WAS THE PONY EXPRESS

Hornet-powered Boeing tri-motored transport landing at Salt Lake City, with another ship waiting to carry on eastward.

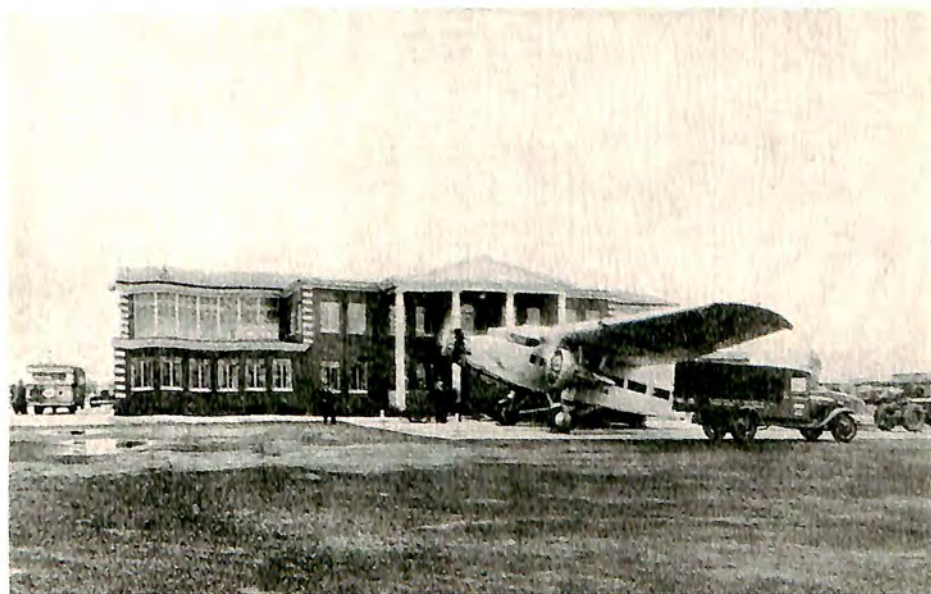

END OF COAST-TO-COAST FLIGHT

Wasp-powered Ford tri-motored transport arriving at United Air Lines terminal on Newark Airport, completing fast trip.

points in the city, being routed over a new through overhead boulevard along the Hudson, then through the Holland Tunnel under the river, and onto a second high-speed highway bridge span, one of the most costly structures of its kind in the world, directly to the airport. It made possible direct service from New York to the airport, 11 miles distant, in from 17 to 26 minutes, depending on traffic conditions. The use of air ferry service across the bay from San Francisco to Oakland was another example of how the air line operators had solved the ground transport problem.

With the opening of 1933, rates on most of the air lines throughout the United States had become stabilized at about rail-plus-Pullman fare levels. Unlike earlier years, 1928 to 1931, there were no wide differences in rates, except in a few cases. Several of the lines raised their rates during the year, while some important through-fares were reduced. The annual study made by the statistical department of the Aeronautical Chamber of Commerce disclosed that the average rate per mile at the opening of 1933 was 5.98 cents. This could be compared with an average of 6.53 cents per mile in January, 1932; 7.01 cents in June, 1931; 7.4 cents in January, 1931; and 12.87 cents in June, 1928, when the first study was made. The 1933 rate was less than half the rate charged in 1928.

Some typical through-fare reductions effected early in 1932 as the lines brought their base rates closer to the rail-plus-Pullman level were: New York to San Francisco or Los Angeles, \$200 to \$160; New York-Cleveland, \$39.75 to \$32; New York-Kansas City, \$82 to \$72.95; New York-Chicago, \$59.50 to \$47.95; New York to Dallas, \$113.25 to \$102.45. These rates remained unchanged at the close of the year. All domestic lines encouraged the purchase of round-trip tickets by offering a 10 per cent. reduction on the total cost of the ticket.

Because each air line profited through close coordination of its schedules with those of every other connecting line, the traffic departments of the air lines were constantly improving their interline arrangements to assure a degree of uniformity which would facilitate the handling of passengers and provide a single high standard of service throughout the country. Much of this work was carried on through the Air Traffic Conference of the Aeronautical Chamber of Commerce, composed of the chief traffic officer of each member line endowed with authority to commit his company on interline traffic matters. The Conference met in Chicago, October 17-18, and completed a series of interline arrangements designed to standardize the policies of member companies on such subjects as interline baggage weights, checking and rates for excess, ticket agencies, meals, ground transportation, publicity and advertising ethics, interline ticketing, interline booking, and a standard reservation telegraph code.

Just as the Air Traffic Conference inaugurated negotiations in 1931



SPEEDY NEW TWA TRANSPORT

Built to specifications of Transcontinental and Western Air, Inc., this new Hornet-powered Consolidated Fleetster goes into service.



NIGHT MAIL SPEEDS ON

Wasp-powered Northrop mail planes make the 23-hour coast-to-coast mail schedule of Transcontinental and Western Air possible.

which led to the sale of air line tickets by the Postal Telegraph Cable Company and Western Union Telegraph Company through their nationwide chain of offices, the Conference recommended in 1932 that the telegraph companies consider the setting up of Central Air Ticket Offices in major cities to carry on a constant program of sales promotion. At the close of the year, Postal already had undertaken the task of setting up these central offices in strategic locations, similar to the one established on Fifth Avenue in New York City in August, 1932. The telegraph companies proved an important sales outlet for air passenger tickets in 1932, the total sales growing from month to month until Postal Telegraph alone reported monthly sales of about 2,500 tickets. The tickets were delivered by the Postal and Western Union messengers directly to the passenger making a reservation, without any additional charge for service or messenger fees.

While the air line traffic departments left no channel closed which might be opened to the further development of passenger traffic, perhaps the year's greatest advance was made in the express traffic field. As we have seen in the preceding chapter, express traffic figures kept soaring month after month as the movement was given added impetus. Postal Telegraph Cable Company again figured in this field when it entered a contract in cooperation with seven air lines placing the messenger and ground transportation facilities of Postal at the disposal of the contracting lines for a fixed charge on all pick-ups and deliveries of air express between the sender, the airport, and the addressee.

The new service, inaugurated October 4, linked American Airways, Eastern Air Transport, Ludington Airlines, Pennsylvania Airlines, Transamerican Airlines Corporation, Transcontinental and Western Air, and United States Airways into an interline system for the handling of air express in the several score cities directly served by these lines, and to points beyond through rail and bus facilities and the services of another air express network embracing four other lines. The new air express organization was known as General Air Express. It provided through shipping arrangements, with all rates compiled into a single tariff, a standard waybill for express consigned over any line or group of lines on the system, and door-to-door pick-up and delivery.

New contracts were made during 1932 between the Air Express Division of the Railway Express Agency and National Parks Airways, Northwest Airways, United Air Lines and Western Air Express, which had offered air express service for several years under a previous contract. Under the new contract, Railway Express Agency continued as the pick-up and delivery affiliate of the four lines and every Railway Express office in the United States became an agent for air express. Shipments were expedited by the high speed air express service, or a combination of air-rail

express between points not directly served by the air network. Reductions in air express rates of from 50 to 80 per cent. made early in 1932 by these four lines, were augmented by further reductions toward the close of the year as the express volume increased rapidly enough to make possible further savings to the shippers.

The rapid development of passenger and express service in 1932 by no means overshadowed the progress made in providing faster, more frequent, and better coordinated service for the millions of pounds of air mail sent by business and social users alike. The air mail poundage for the year



DETROIT TO MILWAUKEE

Taking off from the Detroit River, the Cyclone-powered Loening amphibian of Kohler Aviation Corp. heads for Milwaukee.

showed an appreciable drop as compared with 1931. During the first six months of 1932, the total air mail poundage was about four per cent. under 1931, due wholly to economic conditions which resulted in a more precipitous drop in regular first class mail. Following the action by Congress raising the rate on first class mail from two to three cents per ounce as an emergency measure designed to aid in balancing the budget, the Postmaster General raised the rate on air mail July 6 from five to eight cents for the first ounce and from ten to thirteen cents for each additional ounce. The result at the end of the first month was a decrease of from 20 to 30 per cent. in air mail volume in most cities throughout the country. This precipitous decline slackened and within three months some of the former

losses were made up, so that the year ended with the air mail poundage for the year about 15 per cent. under 1931 figures.

Upon the suggestion of the Post Office Department, the air mail contractors represented in the Air Transport Section of the Aeronautical Chamber of Commerce undertook an extensive campaign designed to inform the public on the rates and advantages of the air mail, and to aid business houses and social users alike in a more intelligent use of the fast service offered. Conferences were held in 45 cities in 28 states and the District of Columbia, called by the Postmaster in each city, to set up a local campaign for air mail development in which the air lines, local civic organizations, prominent business houses, and others cooperated under the direction of the Post Office Department. The Aeronautical Chamber of Commerce, sponsor of the campaign on behalf of the operators, was represented at each of the meetings.

Although the conferences were held chiefly to promote a more widespread knowledge of the advantages of the air mail service, so that the new rate, representing a 60 per cent. increase, might be tested under the most favorable circumstances, it was impossible to ignore the nation-wide reaction to the new higher rates. Business leaders, civic associations, and postmasters themselves requested that every effort be made to have the old air mail rate restored so that business concerns, already hard hit by economic conditions, might have the full advantages of the air mail service in aiding them to speed up the tempo of their business activity. Congressman James M. Mead of New York introduced a bill in Congress early in December calling for a restoration of the two cent first class rate, which would clear the way for a return to the former air mail rate by direct action of the Postmaster General.

The air mail campaign carried on through the Aeronautical Chamber of Commerce, as well as the activities of the Traffic, Operations, Insurance, Maintenance, Business Practices and Radio and Electrical Maintenance Committees of the Section, were directed by the Air Transport Section Committee, composed of the presidents of member lines. Although the Air Transport Section Committee checked closely matters of policy in each branch of activity, it permitted the working committees a wide measure of authority in carrying out their respective tasks within the bounds of the program laid down. All major air transport operators were members of the Air Transport Section and the Air Traffic Conference. The roster at the close of 1932 included: American Airways, Inc., Bowen Air Lines, Inc., Eastern Air Transport, Inc., Ludington Airlines, Inc., National Parks Airways, Inc., Pan American Airways, Inc., Pennsylvania Airlines, Inc., Rapid Air Transport, Inc., Transamerican Airlines Corporation, Transcontinental and Western Air, Inc., United Air Lines, and Western Air Express.

The trend toward consolidation of lines into several major systems con-



ALONG EASTERN SEABOARD

Conqueror-powered Curtiss Condor of Eastern Air Transport, Inc., flying over Atlanta on route to New York terminal.

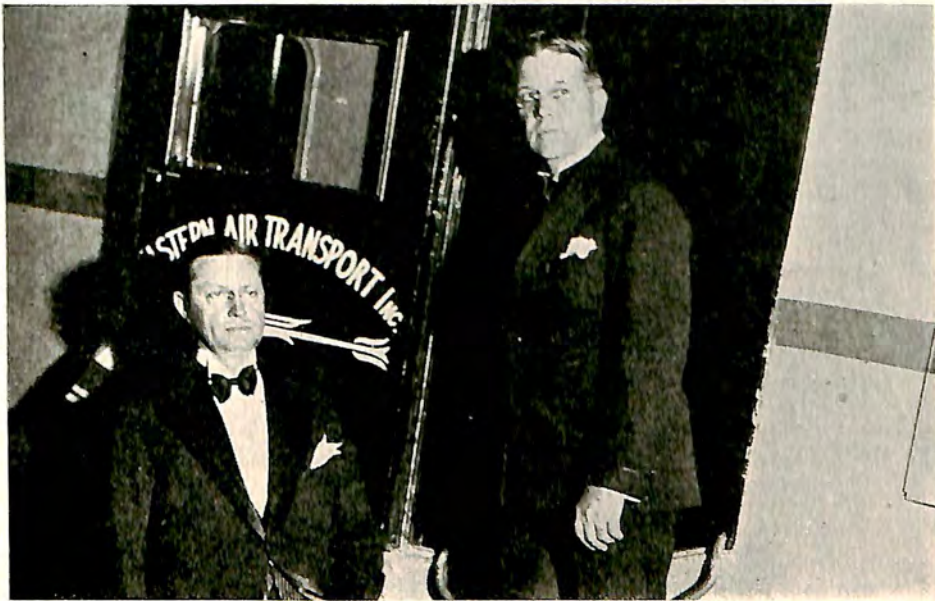

FLYING CABINET MEMBERS

Secretary of Commerce Chapin and Postmaster General Brown in President Hoover's cabinet boarding Eastern Air Condor.

trolled by important financial groups continued during 1932, with several changes of control. The aviation industry found itself accorded attention on the financial pages similar to that which the railroads experienced in their early days when control was a live subject for discussion.

The Aviation Corporation, whose operating subsidiary is American Airways, Inc., figured most prominently in the year's news. Early in the year, the Aviation Corporation purchased the assets of Century Air Lines, Inc., and Century Pacific Lines, Ltd., from the Cord Corporation in exchange for five per cent. of the 2,800,000 shares of the Aviation Cor-



OVER CONTINENTAL DIVIDE

Wasp-powered Fokker Super-Universal transport of National Parks Airways over Table Mountain, just south of Butte.

poration's stock. E. L. Cord took a place on the directorate of the Aviation Corporation, whose president then was LaMotte T. Cohu, successor to Frederick G. Coburn. In the early fall, the management of the Aviation Corporation proposed to purchase certain assets of North American Aviation, Inc., whose wholly owned subsidiary was Eastern Air Transport, Inc., but Mr. Cord obtained an injunction against this action and openly indicated his intention to assume control of the corporation. It then became known that Mr. Cord controlled 35 per cent. of the total stock, and was the corporation's largest single stockholder. A compromise was reached through which Mr. Cord was assured operating control of American Airways, with Lester D. Seymour, former Vice-President in Charge of Opera-

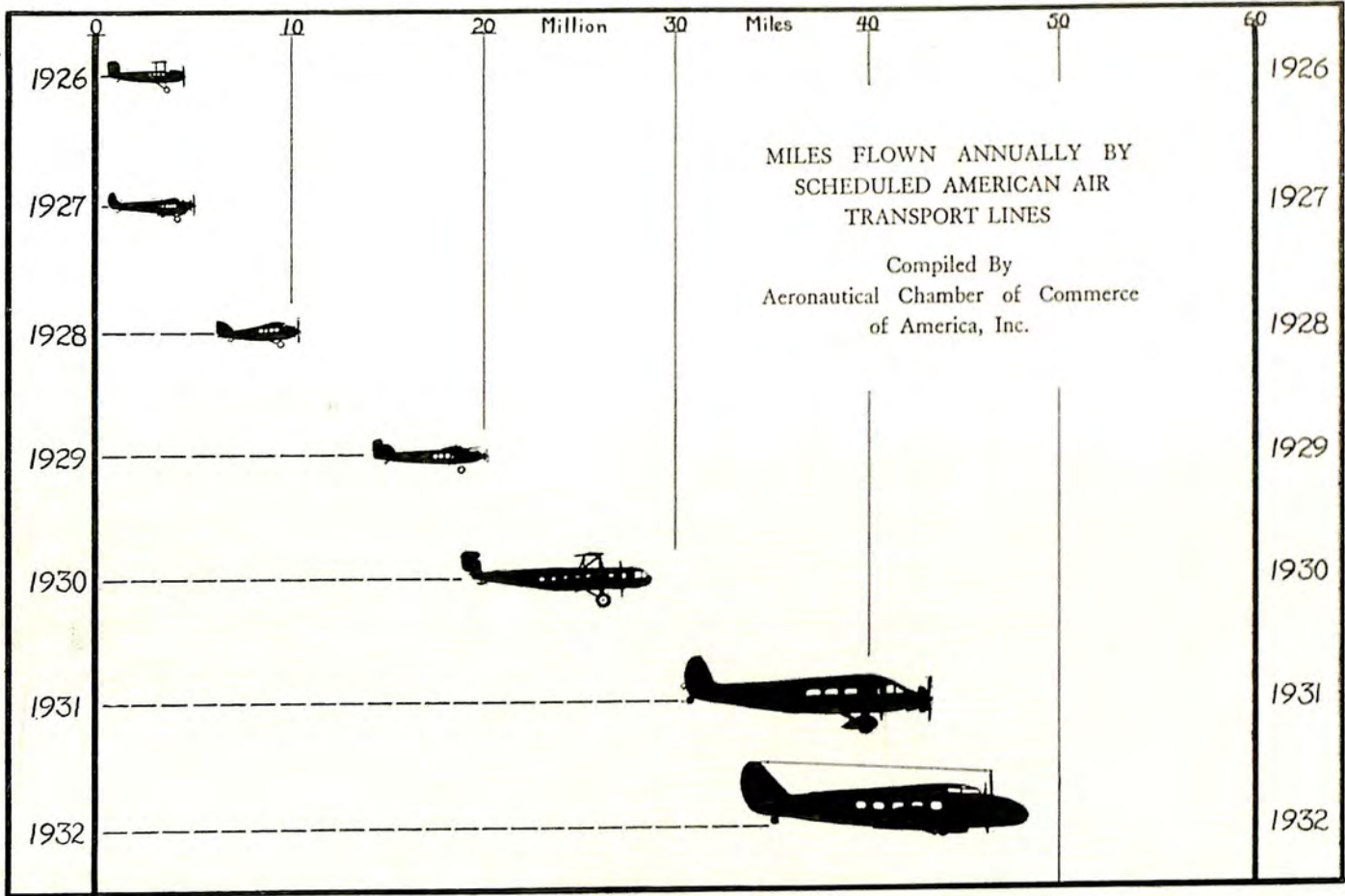

tions for United Air Lines, as president, heading a directorate of five, four of whom were associates of Mr. Cord. Mr. Cohn resigned as president of both the Aviation Corporation and American Airways; the presidencies of the two were separated; and Richard F. Hoyt, prominent in the merger of the Curtiss and Wright interests into Curtiss-Wright and former chairman of the board of Pan American Airways, was elected president of the Aviation Corporation. The Aviation Corporation reduced its directorate to 16 members, with Mr. Cord assured a larger share of representation than he previously enjoyed.

After purchasing a substantial interest in Transamerican Airlines Corporation (Chicago-Buffalo) from Edwin G. Thompson earlier in the year, Mr. Cord obtained control of Transamerican through the purchase of the half-interest controlled by Mr. Hoyt. The controlling interest in the Transamerican properties was offered at cost to the Aviation Corporation by Mr. Cord. His offer was accepted.

The Aviation Corporation sold its Alaskan Airways, pioneer operator in the far northern American territory, to Pan American Airways, Inc., which also acquired the Compañía Nacional Cubana de Aviacion, S.A., from North American Aviation, Inc., as a part of the program for uniting the American effort in the international field under the flag of Pan American Airways. Certain rights and concessions held by Transamerican Airlines Corporation in Iceland, on one of the proposed trans-Atlantic routes, also were turned over to Pan American Airways during 1932.

Transcontinental and Western Air, Inc., formed by TAT-Maddux Air Lines, Inc., and Western Air Express, Inc., to operate the transcontinental mail and passenger service between New York and Los Angeles, continued to carry out its program of expansion and improvement of services under the presidency of Richard W. Robbins, elected in July, 1931, upon the retirement of Harris M. Hanshue. The stock of Transcontinental and Western Air was divided as follows: forty-seven and one-half per cent. to TAT-Maddux Air Lines; forty-seven and one-half per cent. to Western Air Express; and five per cent. to Pittsburgh Aviation Industries Corporation. General Motors, through its aviation subsidiary, General Aviation Corporation, had become an important factor in Transcontinental and Western Air through its purchase of a substantial block of stock in Western Air Express in 1931. As an investor, Transcontinental and Western Air had an interest in Northwest Airways, Inc., as did the Aviation Corporation, but control of Northwest was held by a group of Minneapolis bankers.

Transcontinental and Western Air closely coordinated its services with those of financially affiliated lines, including Pennsylvania Airlines, Inc., the operating company of Pittsburgh Aviation Industries Corporation, and Eastern Air Transport, Inc., a subsidiary of North American Aviation,

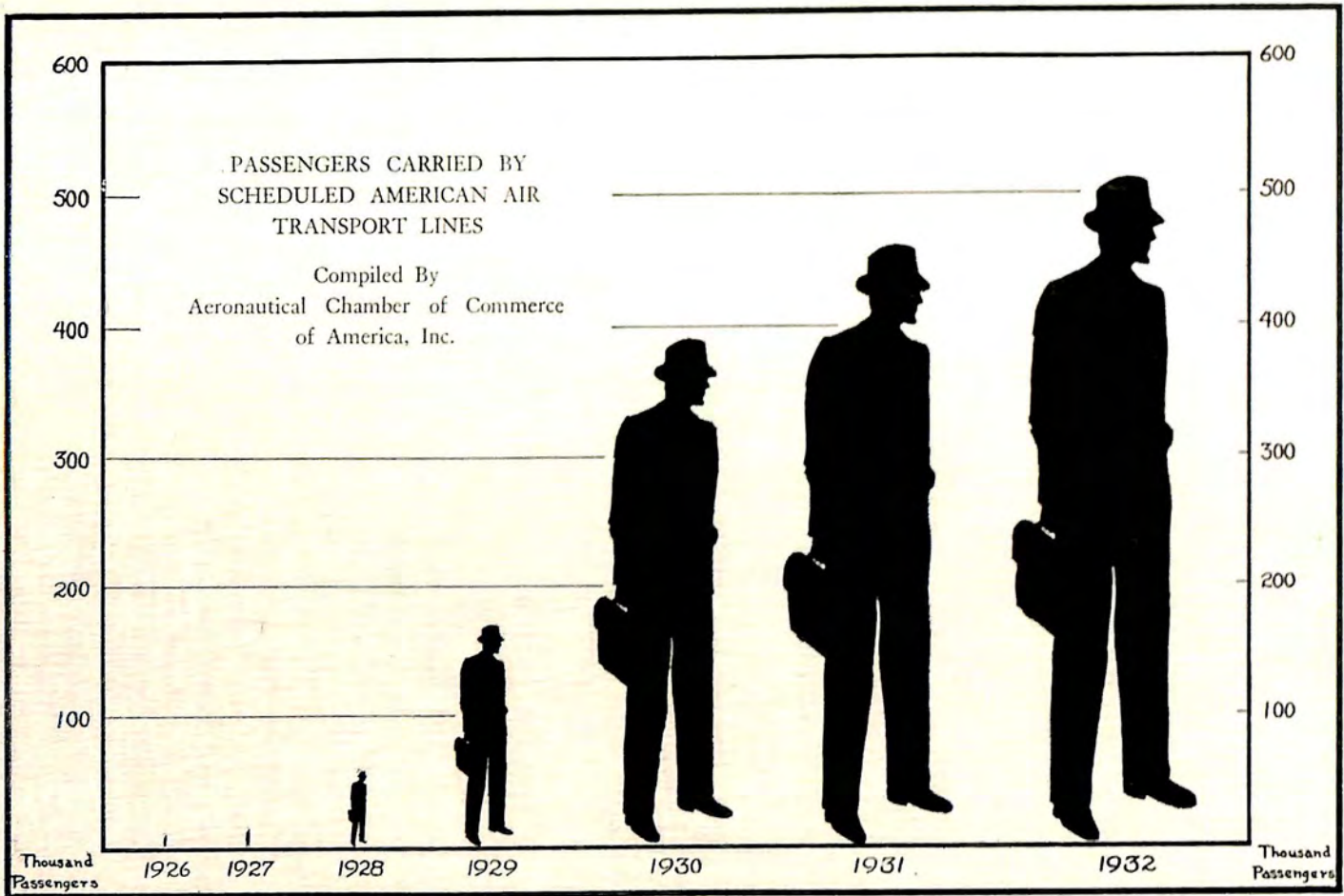

Inc. As an investor, North American Aviation held a substantial interest in TAT-Maddux Air Lines, Inc.

Western Air Express, continuing under the leadership of Mr. Hanshue as president, operated its San Diego-Salt Lake City and Rocky Mountain Division lines—not included in the consolidation with TAT-Maddux—and effected a complete consolidation of the properties of Midcontinent Air Express, under the name of Western Air Express.

United Air Lines, operating division of United Aircraft and Transport Corporation, continued its program of amalgamating its four operating divisions (National Air Transport, Boeing Air Transport, Pacific Air Transport, and Varney Air Lines) into one vast air line network, under the direction of P. G. Johnson as president. Some of United's new services and schedule improvements already have been described. Others will be discussed later as a part of the résumés of 1932 activities for each individual line.

The story of the development of each air transport line composed a picture unprecedented in the history of transportation. While necessarily brief, reviews of the activities of each company, which were not covered in the discussion of major trends, offer an insight into the magnitude of the year's developments. They are arranged in alphabetical order to facilitate future reference. Complete information on cities served, the number of schedules daily on each route, and the character of the service (passengers, mail or express) can be obtained from a study of the accompanying map which was especially prepared for this volume. The relative width of the route lines indicates the relative volume of schedules. The numbers inside the circles indicate the operator of the route, serving as a key to the table printed on the back of the map. The numbers outside the circles indicate the number of trips daily over each route. Attention also is called to the complete statistical tables on air transport operations which will be found in Part IV of this volume, "Flying Facts and Figures." Because this information is provided in such compact form through the map and the statistical tables, such information will be omitted from the following résumés.

American Airways, Inc., the operating company of the Aviation Corporation, ranked first among domestic air line operators in the total mileage of routes included in its vast system, embracing 9,570 miles of airways which extended from New England, through the middle west and south, to California. In total miles flown during the year, however, it ranked second, because some of its routes were flown only during the day or with only one or two round-trips scheduled daily. Sixty-three cities were directly served on the routes of American Airways. Many changes in schedules and services were made during 1932, the most important of which was the inauguration of a night schedule June 15 in each direction

AIR EXPRESS CARRIED BY
SCHEDULED AMERICAN
TRANSPORT LINES

Compiled By
Aeronautical Chamber of Commerce
of America, Inc.

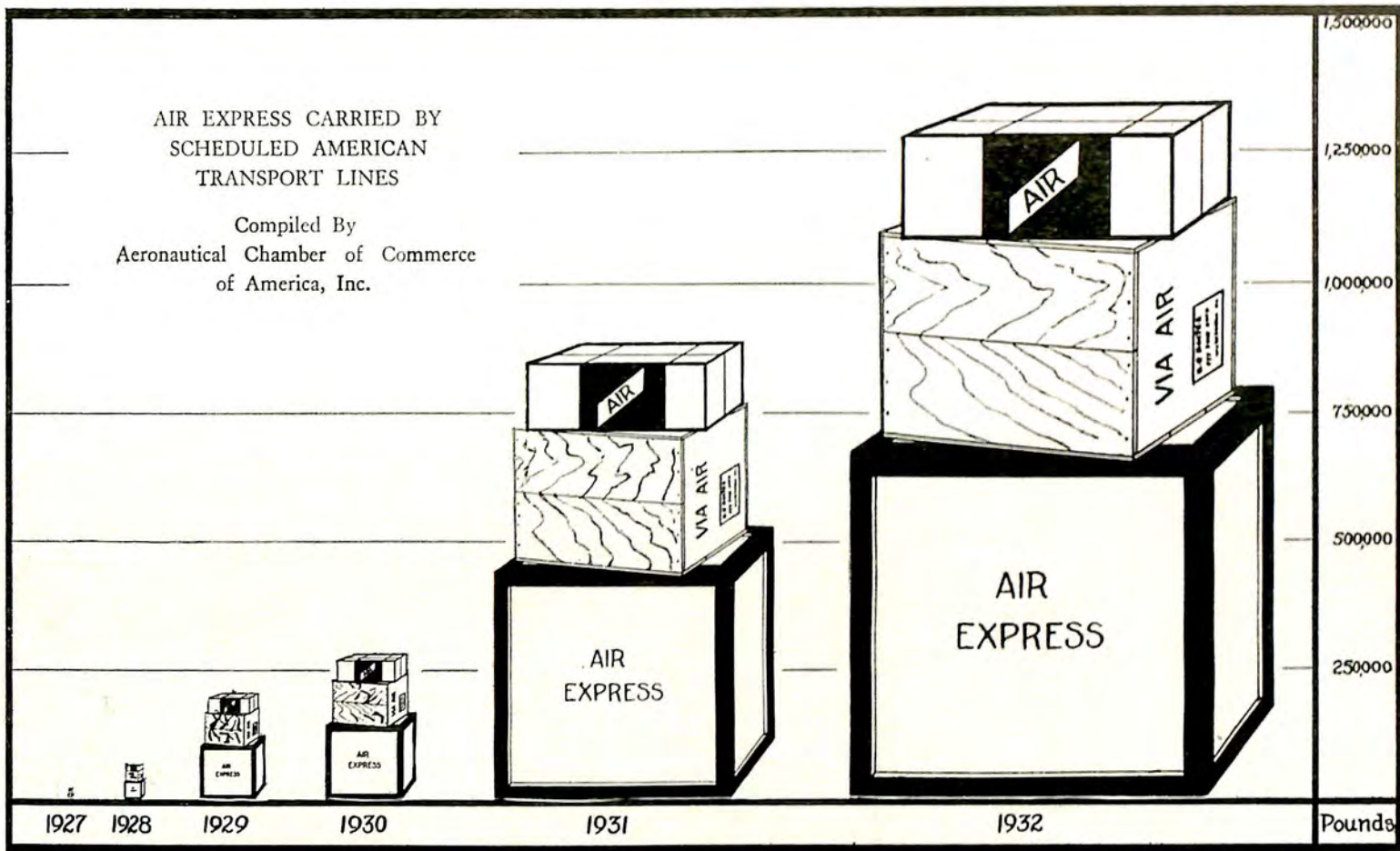

between Dallas and Los Angeles, providing an uninterrupted service for passengers, mail and express over the company's routes from the Cleveland and Columbus gateways to Los Angeles. Passenger service was inaugurated between St. Louis and East St. Louis in April providing connections with all schedules between St. Louis and Chicago. Passenger service was added to the night mail schedules between St. Louis, Kansas City and Omaha on April 19; and passenger service between St. Louis, Evansville, Louisville, and Indianapolis was inaugurated May 1 and extended until October 15. On June 4, passenger service was opened between Atlanta,



CROSSING GREAT SALT LAKE

Wasp-powered Fokker tri-motored transport of Western Air Express reaching Salt Lake City just before sundown.

Montgomery, Mobile, New Orleans, Baton Rouge, Beaumont and Houston. Passenger, mail and express service was started June 15 between Phoenix, El Centro and San Diego; the night Albany-Buffalo mail schedule was made available to passengers; a round-trip service inaugurated between Newark and Albany; and the service from Newark, Hartford and Boston increased from six round trips daily to eight round trips daily. Corpus Christi, Tex., was included as a stop on the Dallas-Brownsville route, June 1; Providence, R. I., was added on certain schedules between Newark and Boston, August 6; and the night Cleveland-Buffalo mail schedule was made available for passengers on August 10. American Airways inaugurated a Business Travel Planning Service during the year to prepare itineraries for

business or pleasure travellers, showing exactly how much time and money could be made by travelling by air on any trip planned. The company was one of the seven lines represented in General Air Express. It also held numerous air mail contracts for its various routes, as shown on the table accompanying the Schedule and Route Map in this chapter.

Bowen Air Lines, Inc., operated 945 miles of routes devoted exclusively to passenger traffic. Lockheed Vega and Orion single-engined transports were used on the routes which featured a high-speed service between San Antonio, Fort Worth, Oklahoma City, Tulsa, Dallas, and Houston.



FIRST TELEVISION EXPERIMENT

First transmission of a television image to an airplane was achieved in June, 1932, to this Western Air Express plane.

Braniff Airways, Inc., was operating 1,420 miles of routes at the close of 1932, specializing in a high-speed service exclusively for passengers. Service between Kansas City and St. Louis was discontinued early in 1932, the planes being re-routed to inaugurate a new service from Chicago to Tulsa via St. Louis, 620 miles. Service between Chicago, Kansas City, Tulsa and Oklahoma City was continued.

Eastern Air Transport, Inc., serving the Atlantic seaboard from New York to Miami on routes totaling 2,554 miles in length, made two important additions to its services in 1932. A new service from New York to Miami, 1,210 miles, was inaugurated June 1 to supplement the previous

mail service from New York to Atlanta by providing a passenger, mail and express service from New York to Richmond, and mail only to Miami. A new route was added to the system December 1 when a line from Charlotte to Augusta, with a stop at Camden and Columbia, S. C., was inaugurated for passengers, mail and express. Express service was inaugurated over the entire system when the company joined six other lines in forming General Air Express. Due to tremendous increases in traffic volume, the company prepared for 1933 business by ordering five of the new design Curtiss-Wright Condors, described in a later chapter. Additions made to the Atlanta maintenance base already have been described. In December, a survey of a new route through the Shenandoah and Tennessee Valleys including 12 cities in six states was made in an attempt to obtain data on the best possible route and local interest in such a project.

Gilpin Air Lines continued the operation of four round-trips daily between Los Angeles and Agua Caliente, Mexico, over its 137 mile airway, cutting the service to three round-trips in October. It was exclusively a passenger service.

Gorst Air Transport, Inc., operated its passenger-express ferry service between Seattle and Bremerton, Wash., with 11 round trips daily during the summer months and eight round trips during the winter. Service was discontinued, however, on October 1 for the first winter since the company started its service. Schedules were to be resumed March 1, 1933.

Hanford's Tri-State Air Lines, Inc., started operations in March, 1932, between Sioux City, Minneapolis and St. Paul, maintaining one round trip daily over its 238 mile route. Lockheed Vega monoplanes were used, the northbound passenger schedule connecting with Northwest Airways, and the southbound passenger service connecting with United Air Lines at Sioux City for Omaha.

Hunter Airways, Inc., began operations in January, 1932, with a service from Tulsa to Muskogee, Fort Smith and Little Rock, extending the line to Memphis in September for a total route mileage of 370. Fokker Super-Universal seven-place planes were used on one round-trip daily passenger schedule.

Inter City Airlines started operations in July, 1932, with three round-trips daily between Boston and Springfield, Mass., 90 miles. Travel Air monoplanes were used in the service limited to passengers.

Kohler Aviation Corporation constructed a new marine air terminal on the downtown Detroit waterfront during 1932 to facilitate the continuation of its service between Milwaukee, Muskegon, Grand Rapids, Lansing and Detroit. Cyclone-powered Keystone-Loening amphibians were used, making water landings at Detroit and Milwaukee and using land ports in central Michigan.

Ludington Airlines, Inc., completed its second year of operation in September, 1932, having carried more than 135,000 passengers on its "every-hour-on-the-hour" service between New York and Washington, with intermediate stops at Philadelphia and Baltimore. At the close of the year, Ludington was operating ten schedules daily in each direction. While tri-motored Stinson transports were used originally on the line designed to provide frequent schedules with low fares, nine-passenger Cyclone-powered Consolidated Fleetsters, capable of 160 miles per hour cruising speed, were added in June, 1932. While a premium fare was charged for the non-stop

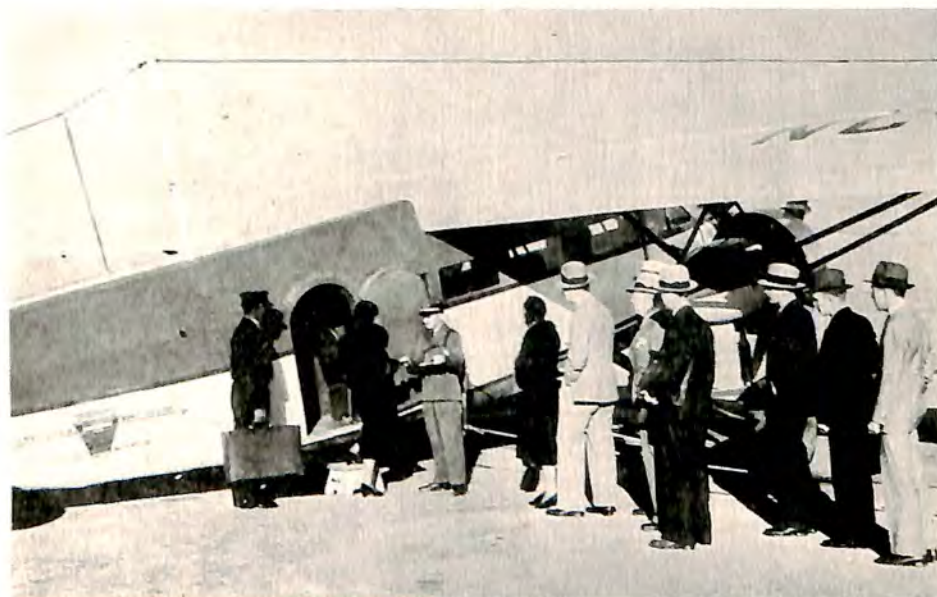

BOARDING STEEL CITY PLANE

Passengers boarding a Lycoming-powered Stinson tri-motored transport of Pennsylvania Air Lines for flight to Cleveland.

New York-Washington 80-minute service when it was first inaugurated, a later readjustment of all passenger fares resulted in the offering of three non-stop round-trip schedules daily as optional services without additional fare. Ludington was one of the seven air lines which organized General Air Express during the year. All services were limited to passengers and express.

Mamer Air Transport, continued its operation of daily service between Spokane and Seattle via Wenatchee, Wash., 252 miles, during the April-September season. Only passengers were carried.

Martz Airlines, established by the Frank Martz Motor Coach Company, continued its passenger services between Buffalo and New York,

with stops at Dansville, Elmira, Scranton, Wilkes-Barre and Stroudsburg.

National Parks Airways, Inc., operating mail, passenger and express service over the mountainous 451 miles of airways between Salt Lake City, Ogden, Pocatello, Butte, Helena and Great Falls, increased its traffic volume during 1932 despite depressed economic conditions in the agricultural and mining district it serves. Fokker Super-Universals and Boeing 40-B mail and passenger transports were used in the service, which maintained its high record of efficiency, with 98 per cent. of the scheduled mileage flown. The company was one of four which signed a new contract with the Air Express Division of the Railway Express Agency early in the year. Passenger fares on the line were reduced to meet the average trend toward rail-plus-Pullman rates.

Northwest Airways, Inc., with routes measuring 1,600 miles in length, served 22 cities in Illinois, Wisconsin, Minnesota and North Dakota. In February, 1932, the weekly service between the Twin Cities and Omaha via Sioux City was discontinued. Schedules were rearranged to provide a connection at Chicago with United Air Lines and a subsequent connection at Cleveland with Pennsylvania Airlines which assured through passenger service from the Twin Cities to Washington, 970 miles, in less than 12 hours, elapsed time. Service between St. Paul and Duluth was maintained with ski-equipped Hamilton metal planes in winter and a Sikorsky amphibion in summer. Northwest Airways was one of four air lines having a contract with the Air Express Division of Railway Express Agency, and offering complete passenger, mail and express services on its routes.

Pennsylvania Airlines, Inc., the operating division of Pittsburgh Aviation Industries Corporation, continued its passenger, mail and express service between Cleveland, Akron, Pittsburgh and Washington, adding an additional night mail schedule over the route during 1932. The company opened a new maintenance base at Cleveland during the year, although major overhauls were centered in the Pittsburgh shops. The executive offices of the company were moved to the Administration Building of Pittsburgh's magnificent new Allegheny County Municipal Airport, new radio facilities were installed on its tri-motored Stinson transports, and considerable improvement made on the facilities along its airway. The company was one of seven allied in General Air Express, and profited from the rapid increase in interline express traffic.

Portland Airways, Inc., started operations in October, 1932, over 250 miles of airway between Portland, Ore., and Walla Walla, Wash., via The Dalles, Goldendale, Yakima and Pasco. Passengers and express were carried in four-passenger Stinson monoplanes.

Rapid Air Transport, Inc., equipped its six-place Bellanca planes with radio during 1932 and continued the operation of its services between



REACHING MOTOR CAPITAL

Wasp-powered Fokker tri-motored transport of Transamerican Airlines Corp. preparing to land at Detroit City Airport.



READY FOR CLEVELAND FLIGHT

Cyclone-powered Loening amphibian in Transamerican Airlines Corp. 55-minute service between Detroit and Cleveland.

Omaha and St. Louis, via St. Joseph and Kansas City, over 406 miles of airways with passengers and express. The company had an arrangement with Western Union for the pick-up and delivery of air express shipments.

Reed Airline, operated six-place Travel Air monoplanes with passengers exclusively over its 125 mile route between Wichita Falls and Oklahoma City, via Lawton. During the first three months of 1932, service also was provided from Oklahoma City to Ponca City, but this route was discontinued in March.

Transamerican Airlines Corporation, purchased late in 1932 by E. L. Cord who sold his controlling interest to the Aviation Corporation, moved its general offices from Cleveland to Detroit early in the year and concentrated its maintenance overhaul at Pontiac. For the fourth successive season, Transamerican resumed its downtown Cleveland to downtown Detroit 55-minute amphibian service in the spring, supplementing the Cleveland-Toledo-Detroit overland service inaugurated in 1931. In October, it resumed operation of the Buffalo-Detroit passenger and express service which had been discontinued in March, 1931. Holding important air mail contracts for most of its routes, Transamerican extended its activities into another traffic field when it joined with six other lines in the formation of General Air Express. Transamerican served 19 cities in Illinois, Indiana, Ohio, New York and Michigan, operating its principal services to points in the latter state. Passenger, mail and express services were provided on most of its routes. The company disposed of its concessions and operating agreements in Iceland, on one of the proposed trans-Atlantic air routes, to Pan American Airways during 1932, devoting all of its attention to the domestic field in which it operated a total of 1,704 miles of routes.

Transcontinental and Western Air, Inc., although it ranked first among all air lines in the United States in 1932 in total pounds of express carried, offered complete passenger, mail and express facilities over most of its routes which totaled 4,268 miles in length and extended from coast-to-coast. The establishment of the fastest air passenger schedules ever operated between the Atlantic and Pacific coasts on November 5, through the inauguration of overnight passenger service between New York and Kansas City and providing connections with its western division, already has been described. The company continued to offer an optional 36 hour coast-to-coast schedule with an overnight stop in a hotel at Kansas City. In April, a new late afternoon schedule in each direction between New York and Pittsburgh, via Philadelphia and Harrisburg, was inaugurated over a 341 mile airway. A new service was inaugurated October 1 between Detroit, Toledo, Fort Wayne, and Indianapolis, connecting with the main line operation to California. The new route was 272 miles long. Schedules

were rearranged November 5 on the southwestern lines of the company between St. Louis, Springfield, Tulsa, Oklahoma City and Amarillo, so that planes would connect at each end of the line with the main line operation, and provide one-day service from St. Louis to Los Angeles and from Amarillo, Tex., to New York. Through connections at Tulsa with other air lines, fast through service from New York and principal cities in Texas was offered. Dayton, O., was designated as a stop on the trans-continental line July 1 to pick up passengers for points west of St. Louis. The company's remarkable new maintenance base at Kansas City already

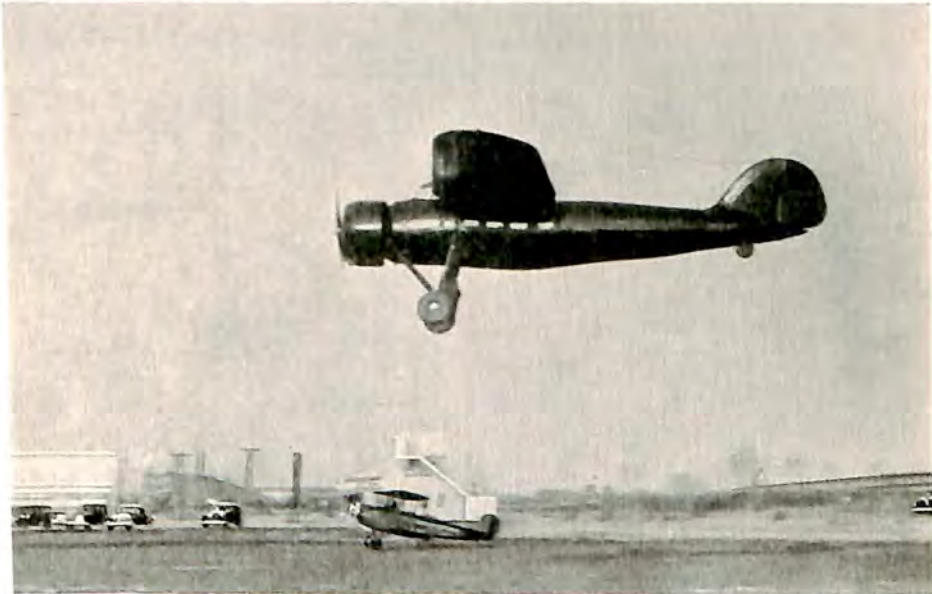

EIGHTY MINUTES TO WASHINGTON

Ludington Airlines' Cyclone-powered Consolidated Fleetster landing at Washington-Hoover Airport on regular service from New York.

has been described. The line also was an important factor in the formation of General Air Express in which seven lines were represented.

United Air Lines, the operating subsidiary of United Aircraft and Transport Corporation, was without doubt the largest air line in the world from the standpoint of total mileage flown. Through its four divisions: National Air Transport (New York-Chicago and Chicago-Fort Worth-Dallas), Boeing Air Transport (Chicago-San Francisco), Pacific Air Transport (Seattle-San Diego), and Varney Air Lines (Seattle-Salt Lake City), United Air Lines flew 14,000,000 miles during 1932, maintaining 95.8 per cent. of its total scheduled mileage for the year. Its passenger traffic

reached a new high for a single month in August when 11,800 revenue passengers were carried. In December, 1932, United celebrated the completion of its 50,000,000 miles of flying, of which 22,000,000 had been flown at night. Serving 45 cities in 20 states, the company's planes were required to fly from sea level to 12,000 feet and at ground temperatures ranging from 30 degrees below zero to 120 degrees Fahrenheit. Its first "one business day" air passenger service from coast-to-coast already has been described. This additional coast-to-coast schedule supplemented the previous one under which passengers left either seaboard in the forenoon and arrived on the opposite coast shortly after the luncheon hour the next day. Inauguration of the first overnight air passenger service between New York and Chicago was linked with closely coordinated schedules at Chicago which permitted the passenger to arrive in Kansas City before noon, and Fort Worth, Dallas and even cities in South Texas, before dinner. With the building up of traffic on the New York-Cleveland-Toledo-Chicago route, United increased its services on that route to six round trips daily, and indicated that it would further increase that service when new ships are delivered in the summer of 1933. In April, the company established the first overnight air passenger service between Chicago and Dallas, and through connections with American Airways expedited service to south Texas points. United's route was extended January 16 when service was started from Watertown, S. D., to Omaha, via Sioux Falls and Sioux City, 259 miles. The company also inaugurated shuttle schedules April 1 between Los Angeles and San Francisco and between Seattle and Portland, devoted to passenger and express traffic. This marked United's debut into shuttle service without mail loads. South Bend, Ind., was added as a stop on some schedules between Chicago and New York. The part played by United in the four-corner air line express system provided in cooperation with the Air Express Division of Railway Express Agency already has been described. So has its plans for a great fleet of twin-engined high-speed transports, and its progress in coordinating maintenance work in centrally located division bases at Chicago, Cheyenne and Portland. United replaced its existing radio equipment during the year with improved two-way sets incorporating improvements developed as a result of three years of experience with the first equipment. While the company had mail contracts on most of its schedules, several were inaugurated during the year without mail loads. Passengers and express were carried on practically all schedules.

United States Airways, Inc., operating over the 564 mile route between Kansas City and Denver, via Topeka, Salina and Goodland, Kan., on a sub-contract for mail from American Airways, cut its service from two round trips daily to a single round trip daily in August. Passengers and express also were carried.

Varney Speed Lines, as the operating name for Varney Air Services, Ltd., increased its service between Los Angeles and San Francisco Bay to four round trips daily with passengers exclusively on high-speed schedules. Some express was carried in addition to passengers on another division which linked San Francisco-Oakland with Sacramento in six daily round trips at high speed. The company's total miles of routes were 420, 70 of which were on the Oakland-Sacramento division. Air Ferries, Ltd., was reorganized during 1932 and operated as Varney Air Ferries providing service to various points in the San Francisco Bay district.



EVERY HOUR ON THE HOUR

Passengers boarding Ludington Airlines' Lycoming-powered Stinson transport in hourly New York-Washington service.

Western Air Express, in addition to holding a forty-seven and one-half per cent. interest in Transcontinental and Western Air, operated service between San Diego and Salt Lake City, and served other cities on its Rocky Mountain division from Denver to El Paso and Amarillo. The night air mail schedule between San Diego-Los Angeles-Las Vegas-Salt Lake City was reestablished by the Post Office Department August 15 after an insistent demand by banks and business houses that the service discontinued January 1 be resumed. The company made substantial increases in its passenger and express volume during 1932, and was one of the four lines participating in the air express service agreement reached with the Air Express Division of Railway Express Agency already de-

scribed. The company planned to supplement its Fokker transport equipment in 1933 with new high-speed multi-motored transports of a new design.

Wyoming Air Service, Inc., operated the 501 airway miles of routes between Denver and Billings, via Cheyenne, Casper and Sheridan with passengers exclusively. Seven flag stops were provided in the heart of the dude ranch country along the way. The company changed to its present name from Wyoming-Montana Air Lines in March, 1932.

CHAPTER IV

"WHO'S WHO" AMONG AIR TRAVELLERS

Presidents And Kings Head Year's Air Passenger Lists—Many Senators
And Congressmen Fly—Diplomats And Industrial Leaders Num-
bered Among Patrons—Every Walk Of Life Represented

HEADED by the new President of the United States, the rapidly growing list of the great and near-great who use air transportation included hundreds of names prominent in the news of the year. Kings and cabinet members, senators and Congressmen, diplomats and governors, financiers and industrial leaders, stars of the stage and screen, and others in many walks of life utilized air transport during the year to speed up the tempo of modern business and international relations or to provide added hours for recreation.

The political campaigns of 1932 brought the airplane into daily use by literally hundreds of candidates and the spokesmen for both parties. Democracy's drive for the Presidency was given a quick start when Governor Franklin Delano Roosevelt and his family sped to the scene of the National Democratic Convention in Chicago in a Wasp-powered Ford of American Airways. A few hours before he had learned in Albany of his selection as the party's standard-bearer while following the proceedings broadcast by radio, and it was the Governor's desire that century-old traditions which surround "official notification" of candidates be swept aside in favor of immediate action.

It was not the first time that the future President had flown, for he had used government planes during his term as Assistant Secretary of the Navy. However, his interest in air travel as a mode of transportation which dovetails perfectly with his desire for immediate and direct action on matters of public importance made it certain that Franklin Delano Roosevelt's name would be recorded as the first in the history of the country who flew during his term of office as President of the United States. What was more, the new occupancy of the White House on March 4th meant the installation of an entire flying family, since Mrs. Roosevelt and every one of her children have become enthusiastic air travellers.

President Theodore Roosevelt, who was in office when motor cars were

substituted for carriages as White House equipage, was the first President to fly. However, he did not fly during his occupancy of the White House; and it is little wonder when one realizes the type of "box-kite" craft available in that day. His widow, Mrs. Edith Kermit Roosevelt, utilized air transport in 1932 when she flew to Washington in August aboard a giant Conqueror-powered Condor of Eastern Air Transport to attend the notification ceremonies of President Hoover.

Mrs. Franklin D. Roosevelt used the air lines frequently during the year. She not only flew with the Governor and other members of the



ROOSEVELT FLIES TO CONVENTION

On first leg of journey that was to carry him to White House, Franklin D. Roosevelt boards American Airways plane for Chicago convention.

family to the Chicago convention, but sped across the country late in September, using the service of Transcontinental and Western Air from Kansas City to Winslow, Ariz., to meet him upon his return from a campaign tour of the Pacific Coast. Shortly after the election, Mrs. Roosevelt flew from Atlanta to New York on Eastern Air Transport, returning from Warm Springs, Ga. Her expressed desire to see New York from the air at night resulted in an invitation from the line's management to make a special flight over the metropolis a few nights later.

The nation elected not only a flying President, but a Vice-President who used the air lines as well as Army planes frequently during 1932. John Nance Garner, as Speaker of the House in the 72nd Congress and

running mate of Governor Roosevelt, was a frequent passenger on lines throughout the country. Leaving a vacation fishing trip in Texas to speed to Albany for a conference with Governor Roosevelt on an important phase of their campaign, Speaker Garner utilized the service of American Airways to hurry him back to Texas following the meeting and thus saved days for much needed rest.

Seven of the ten members of President Hoover's cabinet made frequent use of the air lines or military planes of the Army and Navy at their disposal. The flying members of the Hoover cabinet were Secretary of

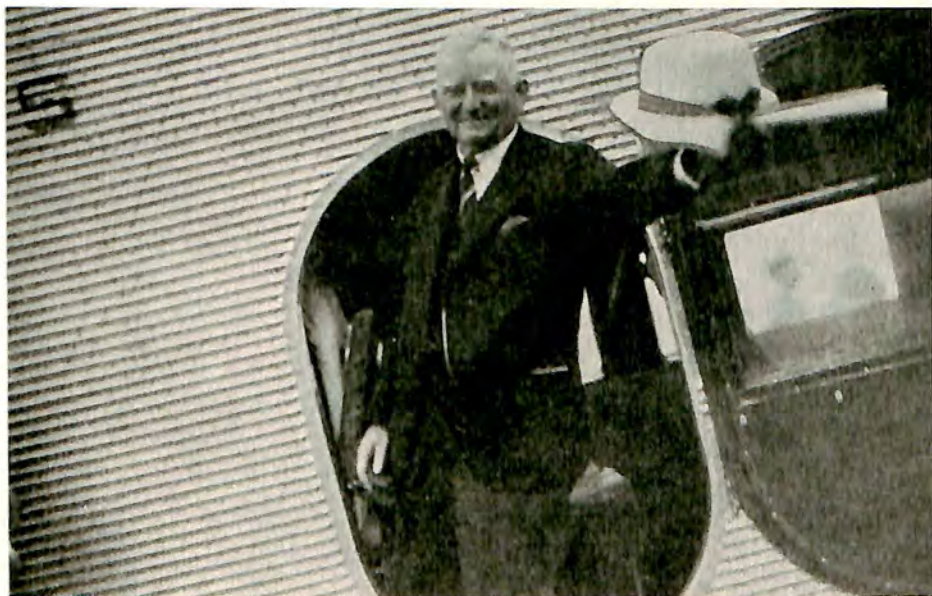

FLYING VICE-PRESIDENT

Vice-President John Nance Garner boarding American Airways' Ford tri-motored transport at Dallas for eastward flight.

State Henry L. Stimson, Secretary of War Patrick J. Hurley, Attorney General William D. Mitchell, Postmaster General Walter F. Brown, Secretary of the Navy Charles Francis Adams, Secretary of Commerce Roy D. Chapin, and Secretary of the Interior Ray Lyman Wilbur.

More than a score of senators in the 72nd Congress had used Army and Navy planes or the air lines on business and pleasure missions, including: Smith W. Brookhart of Iowa, Hiram Bingham of Connecticut, James J. Davis of Pennsylvania, Clarence Dill of Washington, Simeon D. Fess of Ohio, Otis F. Glenn of Illinois, Frederick Hale of Maine, Wesley L. Jones of Washington, John B. Kendrick of Wyoming, George W. Norris of Nebraska, Gerald P. Nye of North Dakota, Key Pittman of Nevada,

David A. Reed of Pennsylvania, Thomas D. Schall of Minnesota, Reed Smoot of Utah, Frederick Steiwer of Oregon, Elmer Thomas of Oklahoma, Robert F. Wagner of New York, Walter F. George of Georgia, Ellison D. Smith of South Carolina, Hamilton F. Kean of New Jersey, Walter F. Walker of Colorado, and Thomas P. Gore of Oklahoma. Senator Carter F. Glass of Virginia had flown with Col. Charles A. Lindbergh, but was partial to the flying colonel as his pilot. Senator William J. Bulow of South Dakota had not flown while holding office in the Senate, although he used air transport as Governor of South Dakota.



MINNESOTA'S FLYING CONGRESSMAN

Like many of his fellow legislators, Representative M. J. Maas of Minnesota uses planes frequently on important trips.

Headed by Speaker Garner, the list of members of the House of Representatives who fly was naturally longer. It included: Henry E. Barbour of California, Gerald J. Boileau of Wisconsin, Joseph W. Byrns of Tennessee, Clarence Cannon of Missouri, Emanuel Celler of Brooklyn, Frank Clague of Minnesota, Robert H. Clancy of Michigan, Arthur M. Free of California, Ralph A. Horr of Washington, W. Frank James of Michigan, Lamar Jeffers of Alabama, Royal C. Johnson of South Dakota, Clyde Kelly of Pennsylvania, Martin J. Kennedy of New York, Paul J. Kvale of Minnesota, James T. Igoe of Illinois, William W. Larsen of Georgia, Fiorello H. La Guardia of New York, James V. McClintic of Oklahoma, Clarence J. McLeod of Michigan, Thomas S. McMillan of South Carolina, John J. McSwain of

South Carolina, Melvin W. Maas of Minnesota, James M. Mead of New York, Ruth Bryan Owen of Florida, Randolph Perkins of New Jersey, Anning S. Prall of New York, Frank R. Reid of Illinois, Edith N. Rogers of Massachusetts, Andrew L. Somers of New York, Philip D. Swing of California, Maurice Thatcher of Kentucky, Gardner R. Withrow of Wisconsin, John S. Wood of Georgia and William R. Wood of Indiana.

The facilities of air transport aided in giving the Democrats an additional vote upon the opening of the second session of the 72nd Congress in December. Senator Walter Walker of Colorado hurried across the

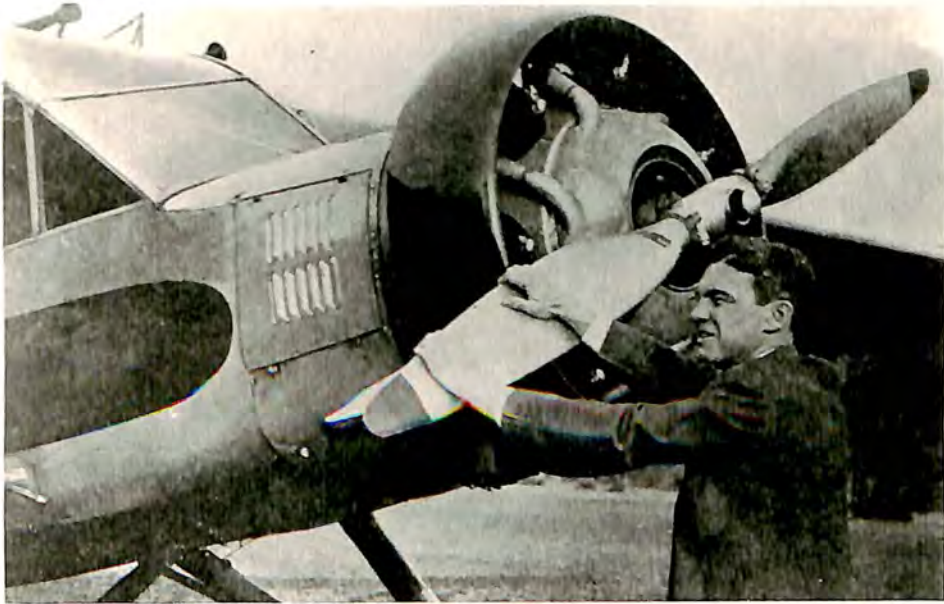

CAMPAIGNING BY AIR

David S. Ingalls, former Assistant Secretary of Navy and candidate for Governor of Ohio, with his Whirlwind-powered C-W Sedan.

country just in time to be present at the opening session after it was learned that, although he had been defeated in the election, he was qualified to occupy his seat for a few days because the Colorado State Canvassing Board refused to issue an official certificate to the successful candidate until all counties had been heard from. One county clerk had not made his report until the time for Congress to convene, and the new Senator-elect, Karl C. Schuyler, a Republican, could not receive his notification until three days after Congress was in session. The trip by air enabled Senator Walker to join his party in the Senate.

During the political campaigns many candidates used the air lines to keep speaking engagements in widely separated sections of the coun-

try, and several used private planes to make tours of their states or districts. William Gibbs McAdoo, for many years an ardent aviation enthusiast and owner of private planes, used his ship on trips to various parts of California during his successful campaign for a seat in the Senate. F. Trubee Davison, Assistant Secretary of War for Aeronautics under President Hoover, campaigned in a Keystone Commuter in his race for the Lieutenant Governorship of New York State. David S. Ingalls, Assistant Secretary of the Navy for Aeronautics in the Hoover "junior cabinet," used his new Curtiss-Wright Sedan to reach every section of Ohio in his race for the Governorship. Scores of other candidates, too numerous to mention, found air transport an aid in covering wide territory during the limited period of the campaign.

The diplomatic corps found air transport suited to its needs during the period marked by many hurried conferences on international economic problems. Sir Ronald Lindsay, the British Ambassador to the United States, and Ambassador Paul Claudel of France frequently used the air lines. John Campbell White, counsellor of the American Embassy in Buenos Aires, saved weeks of travel time through his flight to the United States from Argentina over Pan American Airways. Ambassador Oscar Cintas of Cuba combined the services of Pan American and Eastern Air Transport for quick trips between Havana and Washington. Dana Monroe, United States Minister to Haiti, flew from Port au Prince to Kingston, Jamaica for a conference with the United States Consul there.

Dr. Harmodio Arias, President of Panama, flew to Washington from his home country over Pan American Airways and Eastern Air Transport, and after transacting business in the capital and New York, sped west over Transcontinental and Western Air to attend the Olympic Games at Los Angeles before returning home by air. Former President Ibañez of Chile flew to Santiago from his exile in Argentina via Pan American-Grace Airways when changing political conditions enabled him to return to his country.

Governor Theodore Roosevelt, jr., flew from Puerto Rico to Washington when President Hoover summoned him for a conference in connection with his new post as Governor of the Philippine Islands. When Governor Paul Pierson of the Virgin Islands found it necessary to appear before the House Appropriations Committee, he flew to Washington from his post. Governor Theodore Roosevelt's two sons, Cornelius and Theodore III, flew from Seattle to New York over United Air Lines to continue their studies at Harvard and Groton.

Royalty were included on the year's passenger lists of European air lines, along with the names of Premiers and other state leaders. King Albert of the Belgians flew over Imperial Airways London-Cape Town route to visit the Belgian Congo. Queen Marie of Rumania flew from



FLYING TO HOLLYWOOD

Mary Pickford, motion picture star, boards TWA plane on one of her frequent transcontinental air journeys.



MANY SCREEN STARS FLY

Gary Cooper is another of Hollywood's large circle of motion picture stars who enthusiastically use air travel.

Vienna to Carlsbad in August, and insisted that her son-in-law, Archduke Anton, pilot the plane. Princess Ingrid of Sweden flew to London on a shopping trip in the early autumn. The Earl of Lytton, stricken while serving as chairman of a League of Nations commission investigating the Manchurian situation, flew from Tsinan to Peiping for treatment. The Prince of Wales, without doubt, headed the list of frequent royal air travelers. With his brother, Prince George, he flew to Copenhagen on one of his many trips of the year to open a British exposition there. Premier Ramsay MacDonald of Great Britain commuted by air from his home in



MOTOR MAN AND FUNNY MAN

Henry Ford and Will Rogers end a discussion of "what's wrong with the world" to board Transamerican airliner.

Scotland to London on week-ends, and made many trips to Paris and Geneva. Premier H. U. Moffat of Southern Rhodesia flew to London in June from Africa on his way to the Imperial Economic Conference in Ottawa, Canada.

In America, many stars of the stage and screen were frequent passengers on the air lines. Mary Pickford on one of her trips across the continent over Transcontinental and Western Air turned up a quirk of character for reporters when she made a hurried telephone call to New York from Kansas City, after flying half way across the country, only to learn from her astrologer that the "stars weren't right" for the remainder of the trip that day. She cancelled her Kansas City-New York air trip, but a

week later made the return trip to Hollywood by air. The heavens were favorable. Flying from Washington to New York with her husband, Douglas Fairbanks, Miss Pickford made reservations on the Ludington Airlines. When they reached the airport, Fairbanks asked how many seats there were on the plane, and bought all the places so that he and his wife might make the trip alone.

United Air Lines, American Airways, Western Air Express, Eastern Air Transport, Transamerican Airlines and almost every other scheduled air line in the United States had some of these names on their passenger



AIR COMMUTING CAPITALIST

Truman H. Newberry, Detroit capitalist, commutes between Detroit and Cleveland via Transamerican's 55-minute service.

lists during the year: Will Rogers, Glenn Hunter, Lawrence Tibbett, Fifi D'Orsay, Sue Carroll, Nick Stuart, Helen Kane, Ann Harding, Lynn Fontaine, Earl Carroll, Harry Bannister, Conchita Montenegro, Helene Madison, Rudy Vallee, H. G. Wells, Jeannette MacDonald, Graham McNamee, Thomas Hitchcock, Gary Cooper, Sir Malcolm Campbell, Robert Sherwood, Kay Francis, Jim Londos, Jack Dempsey, Joseph von Sternberg, Francis X. Bushman, Madge Kennedy, Floyd Gibbons, Georges Carpentier, Sydney Lenz, Lilyan Tashman, Mary Roberts Rinehart, Mrs. Alice Roosevelt Longworth, Helen Keller, Edmund Lowe, Heywood Broun, Bernarr Macfadden, Count Felix von Luckner, William Randolph Hearst, jr., Fannie Hurst, Arthur Train, Otis Skinner, Roy Howard, Martin Johnson,

Robert Tyre Jones, Libby Holman Reynolds, Victor McLaglen, Efram Zimbalist, Everett Saunders, George Jessel, and Mabel Walker Willebrandt.

In surveys made by several American air lines, the most frequent answer to the question "For what purpose are you making this flight?" has been "Business." Between 60 and 75 per cent. of the travellers on the air lines are making business trips in which the saving of time means money to them, although many have indicated that their enjoyment of flying is an important factor in their decision. As contrasted with a few years earlier when most passenger flights were made in case of emergencies,

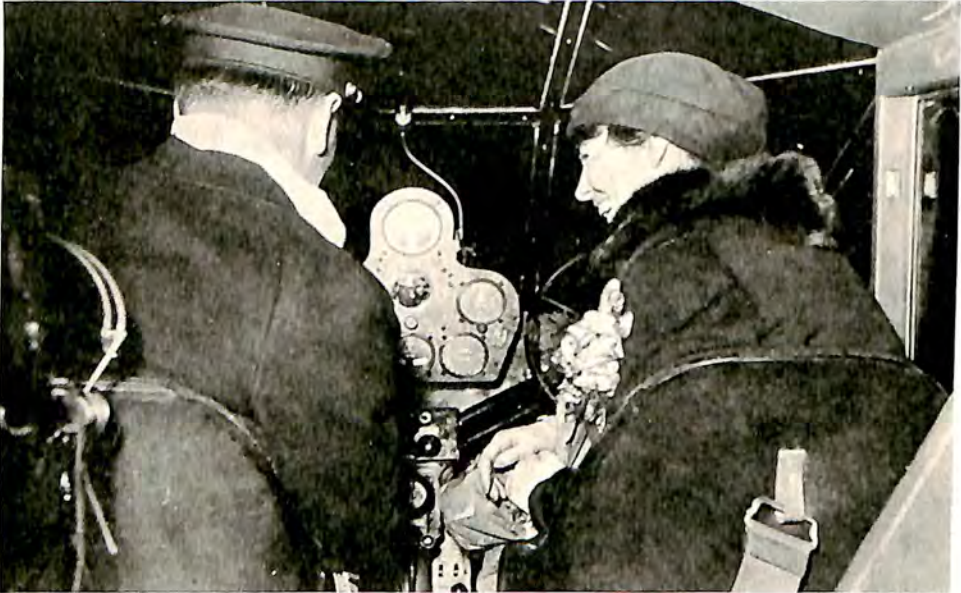

FLYING FIRST LADY

The United States places a flying first family in the White House. Here Mrs. Franklin D. Roosevelt is seen in EAT Condor with pilot.

a very small percentage of the 1932 passengers were on missions resulting from emergencies such as sickness, accidents or death. However, the air lines offered an unusual service to travellers of this class.

Walter S. Gifford, president of the American Telephone and Telegraph Company, flew from New York to Minnesota when his son was seriously injured in a motor car accident, in which a companion was killed. The boy was flown to the Mayo clinic at Rochester for treatment. Dr. Fred H. Albee flew from Baltimore to Venezuela over Eastern Air Transport and Pan American Airways to operate on the son of President Gomez of Venezuela, who was injured in a football game. Scores of similar cases might be cited.

Air travel proved useful in case of business emergencies during 1932, also. Two representatives of the Reconstruction Finance Corporation, A. R. Leroy and John H. McKee, flew over United Air Lines and Western Air Express to Reno, Nev., to inquire into the request of 12 banks for a loan of \$2,000,000 for refinancing during the 12-day banking and debt holiday proclaimed by the Governor of the State. J. Edgar Hoover, head of the Bureau of Investigation of the Department of Justice, was another air traveller frequently seen on the air lines as he carried out his duties of directing the running down of criminals or suspects wanted by the Federal Government.

A "Who's Who" among air travellers would require a volume twice the size of this one. However, it is interesting to get a glimpse of some names on the air line passenger lists who were featured in the world's news during the year



UP WITH THE PEAKS

Passing Mount Rainier, 14,408 feet high, this new Hornet-powered Boeing all-metal bomber carries more than a ton of bombs.

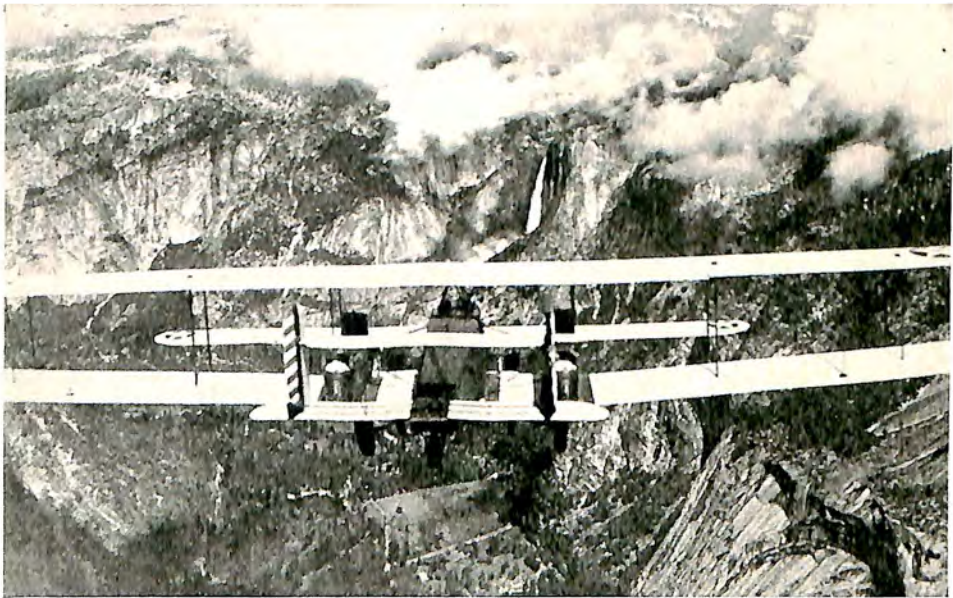

CONDOR OF YOSEMITE

Flying at 13,000 feet headed for Yosemite Falls, this striking view of a Conqueror-powered Curtiss Condor was taken.

CHAPTER V

AIR CORPS: FIRST LINE OF LAND DEFENSE

United States Rated Fourth In Air Strength—Concentrates On Efficiency
Of New Tactical Planes—Five Year Program Still Incomplete
Annual Maneuvers Cancelled For Economy

CURBED by lack of appropriations to complete its Five Year Procurement Program in even the sixth year of operation, the Army Air Corps made its greatest strides during 1932 in development of new tactical aircraft types with greater speed and efficiency. Although the Army Air Corps gained recognition as the "first line of land defense" by military experts, the United States could not be ranked higher than fourth in the strength of its air force compared with the other great powers. France, Italy and Great Britain were known to have greater air strength at their command.

With the strictest economies being made wherever possible, those in charge of the administration of the Army Air Corps turned their attention toward engineering of promising new types of tactical aircraft which might be placed in quantity production to fulfill the Five Year Program as soon as the economic crisis had passed. The aircraft industry met this need with the development of the fastest and most efficient new designs yet submitted to the Air Corps for test.

Emphasizing the necessity for carrying out the Five Year Program and providing a continuing plan for procurement, the Assistant Secretary of War for Aeronautics on December 1, 1932, said: "As the Navy is the first line of defense in our whole scheme of national defense, the air force is the first line of our land defenses. Like the Navy, an air force that is not in existence on the outbreak of war cannot be brought into being until too late to exercise its tremendous power in the early stages of hostilities, when it would be of greatest effect. It will make the first contact for the Army against an enemy in the air, on the ground or afloat. Its state of preparedness in the early stages of a war before ground forces have made contact might well be the decisive factor in determining the outcome."

By reducing the number of flying hours to a bare minimum required for training and by taking advantage of reduced prices for commodities

used in the operation of airplanes, \$1,952,011 was set aside from the 1932 fiscal year appropriation to be returned to the Treasury as a saving. Other economies brought the total amount returned to the Treasury from the 1932 appropriation well over \$2,000,000. However, further reductions in appropriation for 1933 made such savings in the new year impossible, forcing economies which might endanger the Corps' operating efficiency.

For the first time in several years, no large concentration of Army aircraft for maneuvers was staged. The only maneuvers held were within the several corps areas on purely local problems. The value of such tactical



FLYING A PERFECT "17"

Conqueror-powered Curtiss Hawk pursuit planes of the 17th Pursuit Squadron do a little "sky writing."

maneuvers as those held in 1931, when the world's First Air Division was assembled, was not overlooked by military officials, but economy measures dictated their policies. Maj. Gen. Benjamin D. Foulois, Chief of the Air Corps, was awarded the Mackay Trophy during 1932 for his flight leadership of the First Air Division.

While the single-place plane remained the backbone of current pursuit equipment, the Army was able to equip a whole squadron at Selfridge Field, Mich., with the new B/J P-16 two-seater pursuit planes in June, 1932. A tactical service test of the new two-place fighting planes was made in October when six of them made a fast cross-country flight from Selfridge Field, Mich., to Rockwell Field, Cal., and return. The single-place Curtiss

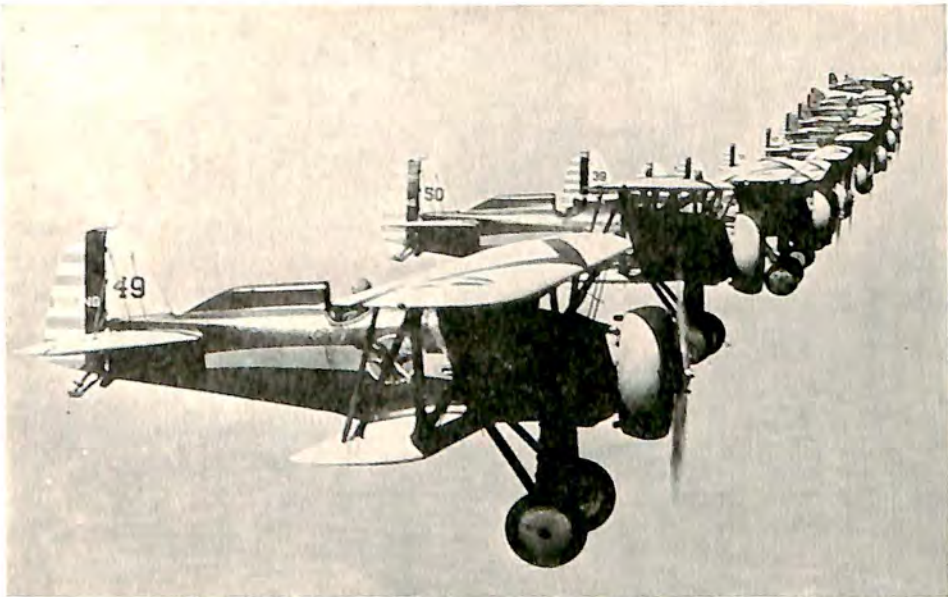

WING TIP TO WING TIP

Wasp-powered Boeing P-12E pursuit planes of the 27th Squadron in formation near Selfridge Field, Mich.



HURDLING HIGH SIERRAS

Two Conqueror-powered Curtiss Condors flying over the snow-covered Sierras on tactical bombardment mission.

P-6E with a liquid-cooled Curtiss Conqueror engine and the single-place Boeing P-12E, with its latest counterpart the P-12F, powered by Pratt and Whitney Wasp air-cooled engines, predominate among the United States Army's pursuit equipment. The Boeing P-26, first known as the XP-936, was the first low-wing monoplane accepted by the Air Corps, representing a distinct departure in pursuit design. Other low-wing monoplanes were to be put on service tests in 1933. A new low-wing all-metal pursuit, the XP-934 (Curtiss Conqueror), with automatic slots and flaps, was delivered late in the year by the Curtiss Aeroplane and Motor Company for Army

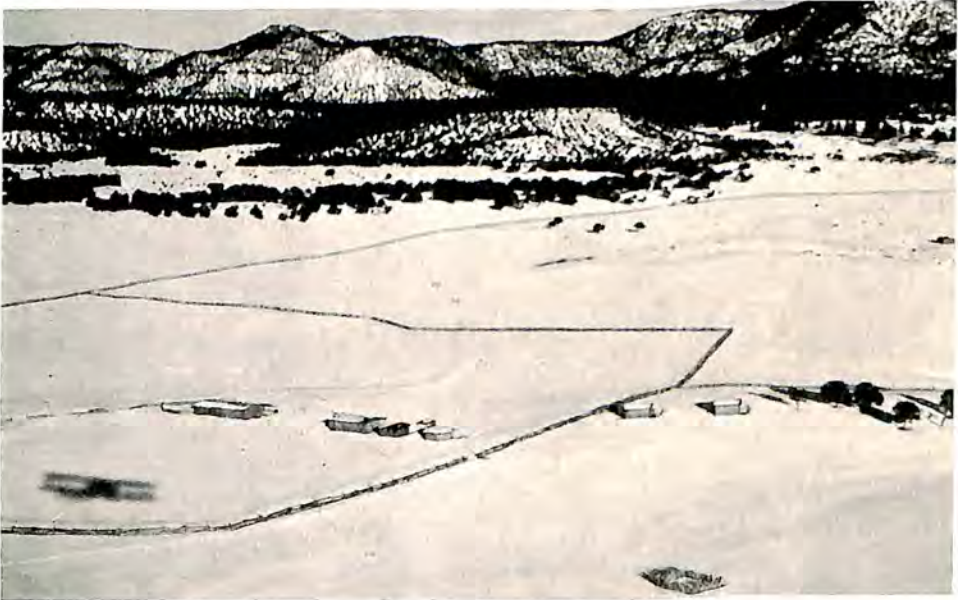

CONDOR OF MERCY

Its shadow on the snow below, a giant bomber prepares to drop food to starving snow-bound Arizona Indians.

tests. Drawings of these designs, as well as most of the others mentioned in this and the next chapter, will be found in Part II of this volume in the section devoted to "Military Airplanes."

Two new types of observation airplanes, with marked departures in design, were introduced during the year to supplement the four standard types in service: Thomas-Morse O-19E, Douglas O-25C, Douglas O-38B, and Curtiss O-39. The Curtiss O-40 (Wright Cyclone) was one of the two new observation planes. Equipped with a retractable landing gear, and dropable gas tank, the new ship was a sesquiplane with a monocoque fuselage and linen covered wings. Its lower wing was well forward of the pilot and since it had only a 30-inch chord, the pilot and observer were



STAIRCASE IN THE SKY

Appearing to ride on each other's wings, these Wasp-powered Boeing P-12E pursuits present a striking picture.

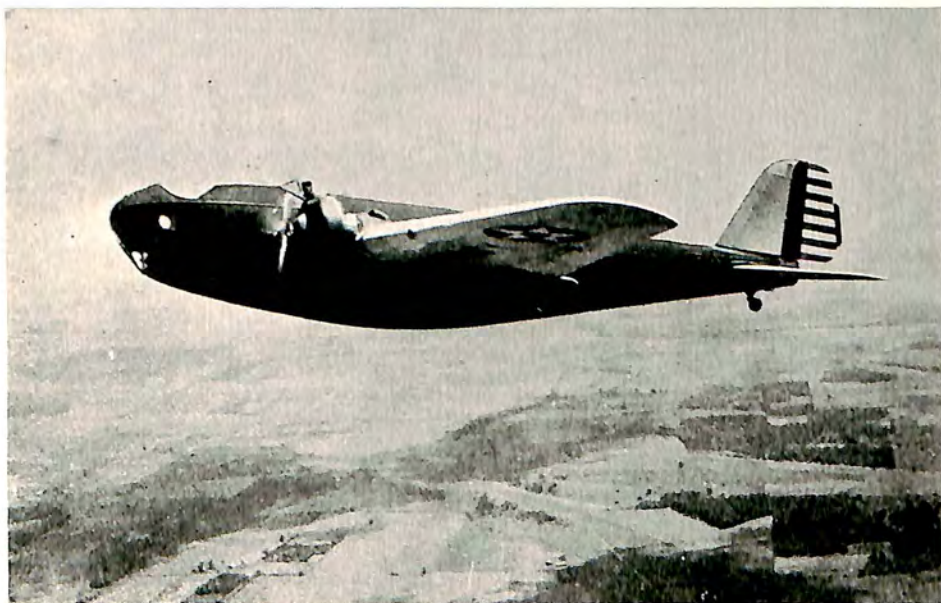

FOR LIGHT BOMBARDMENT

New Cyclone-powered Martin XB-907 light bombardment plane has a monocoque fuselage and retractable landing gear.

afforded excellent visibility. The same design was to be constructed, for tests in 1933, as a monoplane with slots and flaps, and an expected increase in speed. The other new observation type was the Douglas O-31, an all-metal high-wing gull-type monoplane with a Curtiss Conqueror liquid-cooled engine. It was designed for possible use of the new double row air-cooled engine, which was expected to increase its speed to more than 200 miles an hour.

Bombing planes with speeds in excess of standard pursuit types in use two years earlier were the order of the day in 1932. The new Boeing B-9A (2 Pratt and Whitney Hornets) and the Martin XB-907 (2 Wright Cyclones) were both heavy bombers of low-wing all-metal construction with retractable landing gears to add to their high speed. The Douglas B-7 and General Aviation B-8 were light bombers which offered opportunities for conversion to long-range observation planes known as the Douglas O-35 and General Aviation O-27. The standard bombardment planes in service continued to be the Curtiss B-2 Condor and the Keystone B-4 and B-6 biplanes.

Attack aviation made a decided advance during 1932 with the development of the Curtiss YA-8 (Curtiss Conqueror) Shrike, the first low-wing monoplane designed for attack work. Its high speed and general efficiency resulted in a service test order to be completed in 1933. The Curtiss A-3 Falcon continued to be the standard attack type in general use.

With the first year of operation of the new Air Corps Training Center at Randolph Field, Tex., generally known as the "West Point of the Air," the Army reduced the number of flying cadets in training to meet the rigid economies necessary. Two hundred and forty-seven flying cadets completed their course during the year and were commissioned in the Air Corps Reserve with the rating of airplane pilots. The School of Aviation Medicine, established at Randolph Field, made some notable advances during the year including an analytical study of the reasons for cadet flight failures, the development of carbon-monoxide detectors, the study of corrective goggles for pilots, and the value of airplane ambulances for evacuating patients among troops on border defense.

Continuing its development of instrument flying to permit operations under all weather conditions, the Army's efforts for the year were climaxed with the solo flight of Capt. A. F. Hegenberger, who achieved a take-off, fifteen-minute flight over Dayton and a successful landing while closed in a hooded cockpit, without even the protective assistance of a passenger.

Contrary to the general opinion that planes drop only death and destruction, the Eleventh Bombardment Squadron from March Field was sent on an errand of mercy in January after the Indian Bureau, faced with the task of getting food to thousands of Indians isolated on Arizona mesas by a severe blizzard, turned to the Army Air Corps. Operating in ex-



AN ARROW IN THE SKY

Conqueror-powered Curtiss Hawk pursuits of the 17th Pursuit Squadron in unusual demonstration of precision.

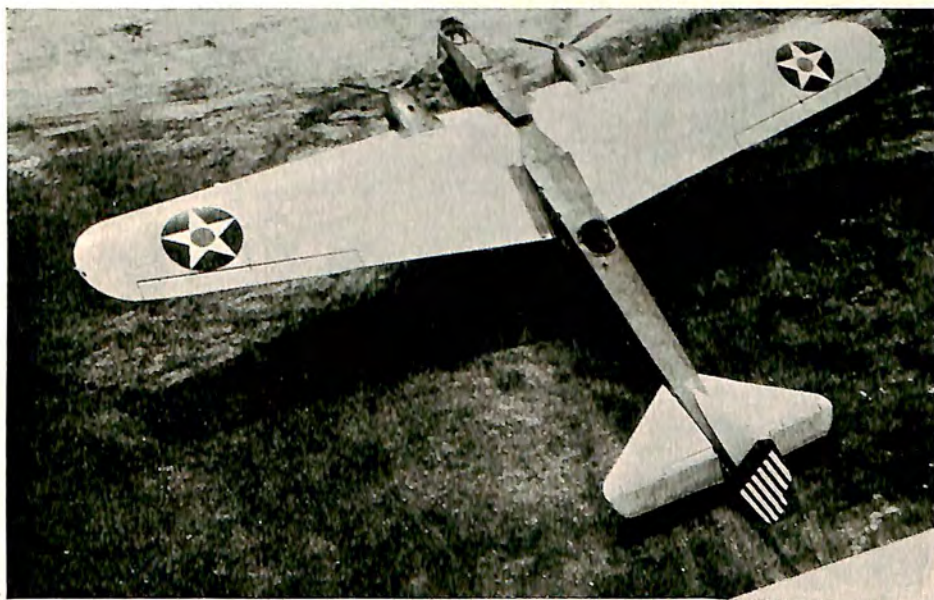

NEW TYPE OBSERVATION

New Conqueror-powered ship perfected by General Aviation Corp. late in 1932 for delivery to Army Air Corps.

tremely cold weather over desolate and little known country, the big bombardment planes literally bombed the Indians with 15 tons of foodstuffs within 24 hours after receiving their orders.

Pilots of the Regular Army and Organized Reserves flew a total of 371,254 hours during 1932. The number of fatal accidents in 1932 increased from 21 to 33 and the resultant number of fatalities from 26 to 50. The number injured increased from 75 to 89. This was at the rate per fatal accident of 0.088 per 1,000 flying hours as compared with 0.053 for the previous year. While this represented an increase in the fatality rate over the previous year, it was lower than that of any other previous year. A thorough analysis of all aircraft accidents was made with a view to eliminating the underlying causes.

CHAPTER VI

PREENING WINGS OF THE FLYING FLEET

Naval Aviation Maintains High Operations Record—Plays Prominent Role
In Fleet Maneuvers—Reduced Appropriations Force Strict
Economies—New Aircraft Carrier Ready In 1934

WRESTLING with knotty problems growing out of reduced appropriations, the Navy entered 1933 after a year of brilliant performance in its aviation operations. All tactical units, except those of the Marine Corps, were assigned to the active fleet and spent a year crowded with activity in carrying out missions which ranged from flying off the ice-encrusted decks of the "U.S.S. Langley" in the North Atlantic to operations in tropical cloudbursts in the Pacific.

All battleships were supplied with three operating planes, 8-inch cruisers with four, 6-inch cruisers with two, the aircraft carriers "Lexington" and "Saratoga" with 72 each, and the "Langley" with 29. Patrol and utility airplanes operated with the base and scouting forces, with other patrol planes based at the Coco Solo, C.Z., and Pearl Harbor, Hawaii, fleet air bases. For the first time in history, Marine Corps aviation went to sea, one squadron of Marines being placed aboard each the "Lexington" and "Saratoga." The aircraft carriers were equipped with scouting, torpedo and bombing, observation, and fighting planes, while catapults on the battleships and cruisers permitted the operation of scouting and observation planes.

Fleet aircraft participated in all maneuvers and concentrations during the year, operating under all conditions encountered. The splendid performance of the Navy's planes was evident from the records made during the fleet maneuvers off Hawaii in February, the concentration of more than 240 naval aircraft at San Diego in July, and the year-round operation of planes from the decks of the fleet. There was a further improvement in the number of hours flown for each forced landing due to power plant failure. This increased reliability enabled the Navy Department to continue its policy of purchasing only 50 per cent. spare engines for future planes. The Navy's safety record also continued on a high plane of efficiency, not a single life ever having been lost on battleships or cruisers due to malfunctioning of the catapults, and only two deaths occurring in

the tens of thousands of landings made on the restricted platforms of the aircraft carriers since their first operation in 1922.

The Navy, Marine Corps and Reserves flew a total of 247,745 hours during the year in heavier-than-air craft with 22 fatalities, making 11,261 hours of flying for each fatality. When it is considered that this figure is derived by including three deaths caused by propeller accidents, it can be seen that the Navy's actual flying record is exceedingly high. The Navy also flew a total of 3,346 hours during the year in lighter-than-air craft, without injury to a single passenger or crew member.

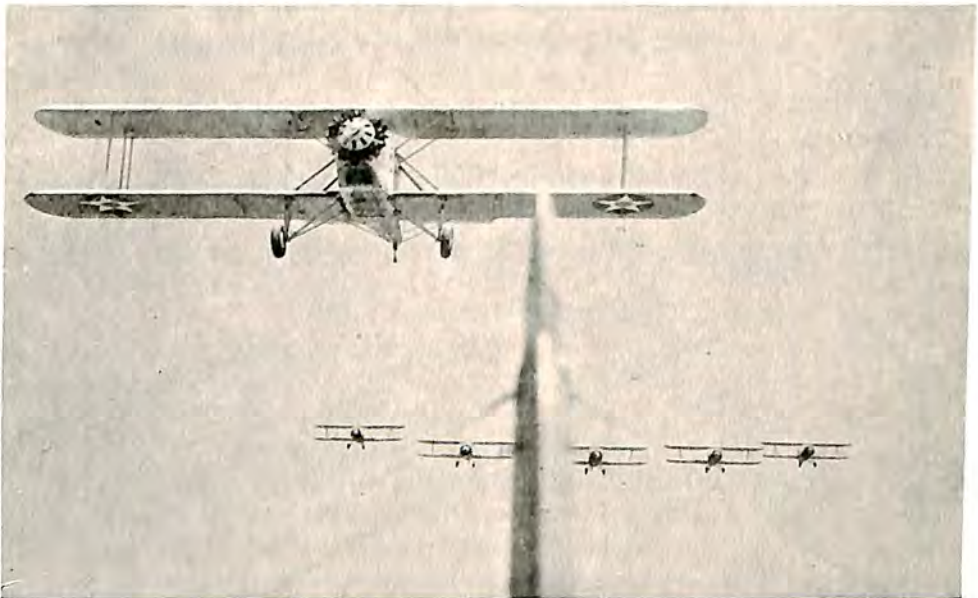

CLOSE ON HIS TAIL

Cyclone-powered Martin torpedo plane and scouts during maneuvers with the Aircraft Squadrons, Battle Fleet.

Development of faster scouting planes and speedier fighting planes, the use of long distance patrol planes based on tenders and on fleet air bases, the increased service given by aircraft aboard battleships and cruisers, and the greater employment of catapult-launched planes from ships of the fleet all were features of the year's progress. A fast experimental two-seater fighter with retractable landing gear passed successful tests, and was considered a particularly important development by military air experts who agree that for tactical purposes the two-place fighter will eventually supplant the single-seater. The Navy conducted performance tests or acceptance trials on 36 different types of planes built under Navy contract to determine the types best suited to naval aviation.



FLEET ON MANEUVERS

With the aircraft carriers "Saratoga" and "Lexington" in the middle background, the fleet anchors in Hawaii.



NEW JOB ON BATTLESHIP

Airplane signal man on "U. S. S. West Virginia" relaying catapult orders from the bridge to pilots awaiting orders.

Construction of the new 13,800 ton aircraft carrier "Ranger," scheduled for completion early in 1934, was continued throughout the year. One hundred and fourteen planes were authorized for the new carrier, but Congress had not appropriated money for their procurement, causing considerable concern among officials in charge of naval aviation who realized that they could not provide this complement of planes from the 960 serviceable ships already in use without eliminating or reducing other very necessary units of the aeronautical organization.

The lack of parity in aircraft carrier tonnage between the United States



"HIGH HAT" FIGHTER

Wasp-powered Boeing carrier fighter of the "High Hat" squadron taking off from flight deck of "Saratoga."

Navy and the navies of the other great powers was a further subject of deep concern to officials charged with the task of providing the country with an adequate naval air arm. Under the Arms Limitations Treaties, the ratios set up were United States 5, Great Britain 5, and Japan 3. The opening of 1933 found the ratios: Great Britain 5, United States 3.9, and Japan 3. Both Great Britain and Japan had taken advantage of building up their aircraft carrier tonnage, while the United States lagged.

Under the treaties, the United States and Great Britain may build 135,000 tons of aircraft carriers. The "Lexington" and "Saratoga" utilize 66,000 tons of the allowed quota while providing but two landing decks. Great Britain had five excellent carriers to two for the United States.



EYES RIGHT

In straight line formation, Wasp-powered Boeing F4B-1 carrier fighters during 1932 fleet maneuvers.

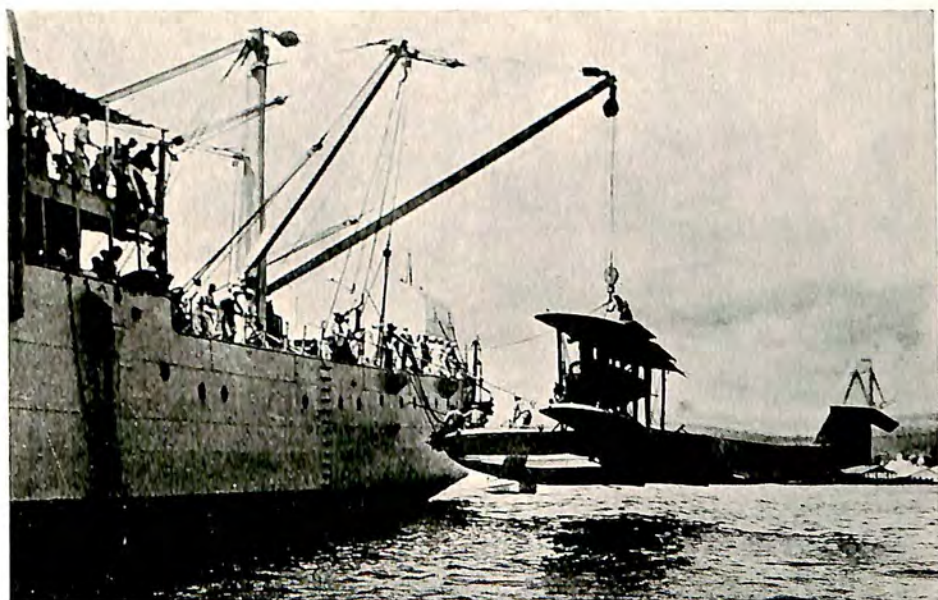

NAVY'S WINGED PATROL

Cyclone-powered Keystone PK-1 patrol boat being hoisted aboard a cruiser in Hilo Harbor, Hawaii, during maneuvers.

Japan, building almost to her allowed limit, had four landing decks. Lack of parity was even more acute when it was realized that three British carriers were classed as "experimental," and could be replaced at will.

Future plans have pointed to the necessity of constructing flight deck cruisers and additional aircraft carriers, with their appropriate complements of planes, if the United States is to have an adequate naval air arm. Experts in the Navy claim that the United States should have from 14 to 18 aircraft carriers for a balanced Navy. Under the treaty, the United States was permitted 14 vessels fitted with landing decks, including flying-deck



FIGHTING POWER

The Curtiss F11C-2, powered with the latest Wright Cyclone, goes through its paces.

cruisers. The placing of landing decks on 25 per cent. of the allowed cruiser tonnage was recommended by Rear Admiral William A. Moffett, who continued to so ably direct naval aviation as Chief of the Bureau of Aeronautics. This would partly remedy the United States' inferiority in carrier tonnage, but obviously could not be overcome during the life of the treaty which expires December 31, 1936.

In the interests of economy no flying-deck keels were laid during 1932. The "U.S.S. Jason" was decommissioned to conserve funds, reducing naval aircraft in Asiatic waters to a utility unit of two planes assigned to the "U.S.S. Heron" and four planes attached to the "U.S.S. Houston." Because no funds were carried in the 1933 Appropriations Act for operation and

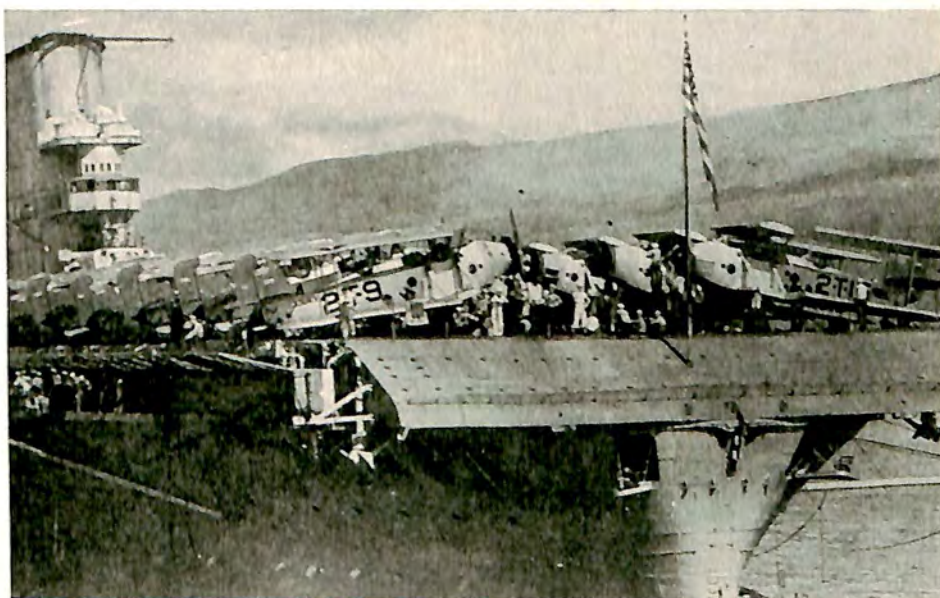

ON BACKS OF THE FLEET

Hornet-powered Martin bombers stowed aboard the aircraft carrier "U. S. S. Saratoga" with wings folded back.



PASS IN REVIEW

Seventy-eight planes caught with one snap of the camera during 1932 review at Naval Air Station, San Diego.

maintenance of the airship "Los Angeles," the veteran ship was decommissioned June 30, 1932, but held in readiness to continue its service on 30 days notice. The "U.S.S. Akron," the first fleet airship and aerial airplane carrier, completed its first year of service with notable success, described more fully in a later chapter. Work went forward on her sister-ship, the "U.S.S. Macon," scheduled to be launched in 1933.

As a result of making every possible economy, the Navy Bureau of Aeronautics achieved a total saving of \$3,541,103, representing 11.4 per cent. of the amount appropriated by Congress for the year. The saving



TWIN-ROW ENGINE

Rear Admiral Moffett inspecting first installation of the Twin Wasp Junior engine with controllable pitch propeller.

was made possible by successive reductions in the operating force plan of the Navy, the abnormally low price of aviation gasoline and oil, the reduction of spare engines from 100 to 50 per cent., and the reduction in quantity of structural spares to be purchased. For the fiscal year 1933, Congress reduced the naval aviation appropriation by \$7,084,580 from the 1932 sum, making necessary the most drastic economies and eliminating any possibility of closing the year with a saving.

In his report to the Secretary of the Navy made public December 11, 1932, Rear Admiral Moffett called attention to the necessity of a continuing program of aircraft procurement to keep the sources of supply intact. "I again desire to invite attention to the serious condition in this country of



LAYING SMOKE SCREEN

Planes of the United States Navy laying smoke screen during maneuvers in California during 1932.

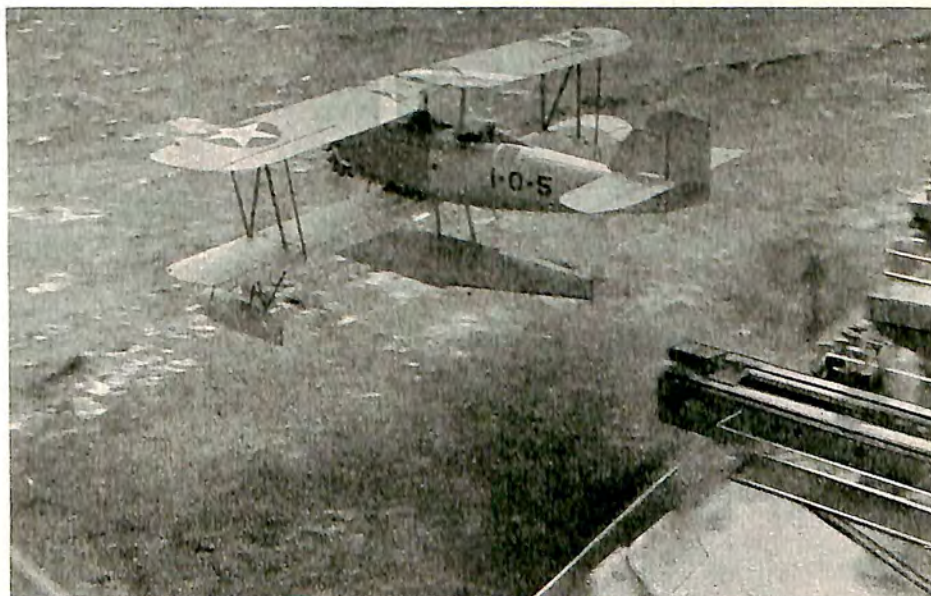

CATAPULTED INTO AIR

Wasp-powered Vought Corsair being catapulted from one of the Navy cruisers during fleet maneuvers.

the aeronautical industry," Admiral Moffett said. "Due to the present economic situation, the aeronautical industry is largely dependent upon the business obtained from the Army and Navy. To provide for the future welfare of both the government and the industry, it is essential that well-established firms be enabled to remain in business. This can be done only by a reasonable volume of experimental and production orders resulting in fair profits."

CHAPTER VII

PROSPECTS BRIGHT IN AIRSHIP FIELD

"Macon" Ready To Join "Akron" in Navy Service—Trans-oceanic Services
Hinge On Congressional Action—"Graf Zeppelin" Makes 18 Trans-
Atlantic Flights In Year—"Los Angeles" Retired

AWAITING the enactment of legislation by Congress extending to airships the same privileges already accorded steamships, the United States entered 1933 ready to carry out a program for construction of giant commercial airships for trans-Atlantic and trans-Pacific service. Such a program would utilize the great storehouse of experience built up by American engineers in the successful construction of the world's largest airships, the "U.S.S. Akron" and the "U.S.S. Macon," as well as hold intact the highly specialized corps of engineers and workmen in Akron.

The Merchant Airship Bill, introduced in the House of Representatives by Congressman Robert Crosser of Ohio, was passed by the House. The bill before the Senate, introduced by Senator McNary of Oregon and similar to the Crosser measure, was favorably reported to the Senate by the committee, but because of measures dealing with unemployment, farm relief, soldiers' bonus and similar matters, the bills were deferred for consideration until the 1932-33 winter session of Congress. The bills would extend to airships the provisions of existing legislation covering steamships, except that the ship construction feature of marine legislation was not included and no appropriation for construction was asked. Airships would be enabled to carry mail abroad under the same schedule in effect on ocean-going liners.

The "U.S.S. Akron," built by the Goodyear-Zeppelin Corporation for the U.S. Navy and commissioned late in 1931, was in its second year of service, after flights covering thousands of miles, up and down both the Atlantic and Pacific coasts and twice across the continent, to test her mettle against severe wind, rain, snow and electrical storms. The "U.S.S. Macon," sistership of the "Akron," was scheduled to take her place in the Navy's service in 1933 with a base at Sunnyvale, Cal. The "U.S.S. Los Angeles" completed eight years of faithful service and won the distinction of being the "grandfather of them all" when it was finally decommissioned in 1932

because of shortage of Navy funds. The "Graf Zeppelin," with more than 300 flights to her credit, made eighteen successful crossings of the South Atlantic during 1932 on a regular schedule between Germany and Brazil.

The splendid records of these American and German airships, covering thousands of miles over land and water, withstanding tropical cloudbursts and terrific gales without injury to a single passenger or crew member, stimulated the interest of the American capitalists interested in trans-oceanic commercial services with airships even larger than the "Akron" and "Macon."

The International Zeppelin Transport Company, representing both American and German interests, and the Pacific Zeppelin Transport Company, an entirely American enterprise, completed their preliminary studies on Atlantic and Pacific coast terminal sites, on operating costs, and best weather routes during 1932. The former is looking to the establishment of a trans-Atlantic airship line, while the latter hoped to inaugurate a line from the west coast of the United States to the Hawaiian Islands and eventually to the Philippines and the Orient.

Work on the "U.S.S.Macon" in the Goodyear-Zeppelin dock at Akron, O., was pushed throughout 1932 to insure her launching on schedule in the spring of 1933. Named in honor of one of Georgia's leading cities, the "Macon" is almost a duplicate of her sistership, the duralumin skeleton construction, the outer covering, the shape and size of the two being identical. The differences between the two ships are of a minor nature growing out of experience gained in the construction and operation of the "Akron." Instead of one helium valve hood for each gas cell, as used on the "Akron," the new ship has two to four smaller hoods for each cell, offering less air resistance and thereby contributing to an increase in speed.

The "Macon" is about 8,000 pounds lighter than the "Akron," yet possesses the same strength and efficiency. Weight savings were made in the gas cells, electrical systems, engine mountings and elsewhere. When the "Akron" first took the air, half of her gas cells were of rubberized fabric and the other half of a gelatin-latex construction, a Goodyear development. Experience proved that the latter material was superior to anything previously used, including goldbeaters' skin, and consequently all of the "Macon's" cells are of the newly developed texture. The "Macon" has an automatic telephone system, constituting the world's first flying dial phone system, with a total weight of only 225 pounds including 19 instruments strategically located throughout the ship, switchboard, cable and other necessary equipment.

Other departures found in the "Macon" affect the fuel and ballast layouts, control system, heating arrangements and other features, all designed to decrease weight and increase efficiency. The improvements are evidences

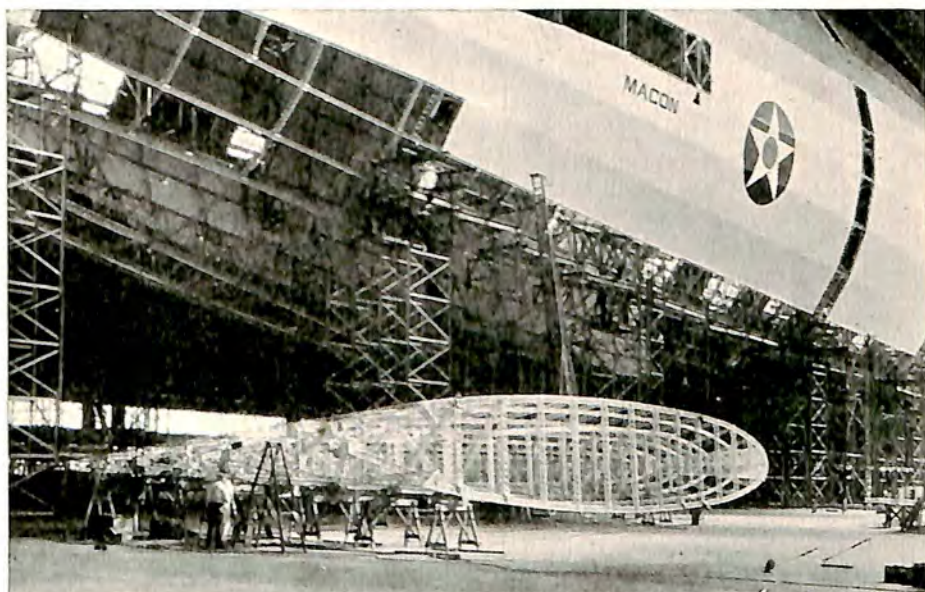

CONSTRUCTING "U. S. S. MACON"

Scheduled to join the "Akron" in service in 1933, the "U. S. S. Macon" is being covered, with top fin under construction beneath.



RAISING "MACON'S" NOSE

With appropriate ceremonies July 4, 1932, the "Macon's" nose is raised into place, completing framework of giant airship.

of normal growth in design which might be expected as the result of two years added experience since the construction of the "Akron." While consideration was given to substantially increasing the "Macon's" size over that of the "Akron," plans were finally dropped because funds were not available. Either ship, however, could be enlarged by nearly 1,000,000 cubic feet capacity by adding another gas cell in the center of the ship.

With the advent of 1933, the Goodyear-Zeppelin Corporation had under construction for the United States Army the largest non-rigid airship in the country, known as the TC-13. It was scheduled for completion in

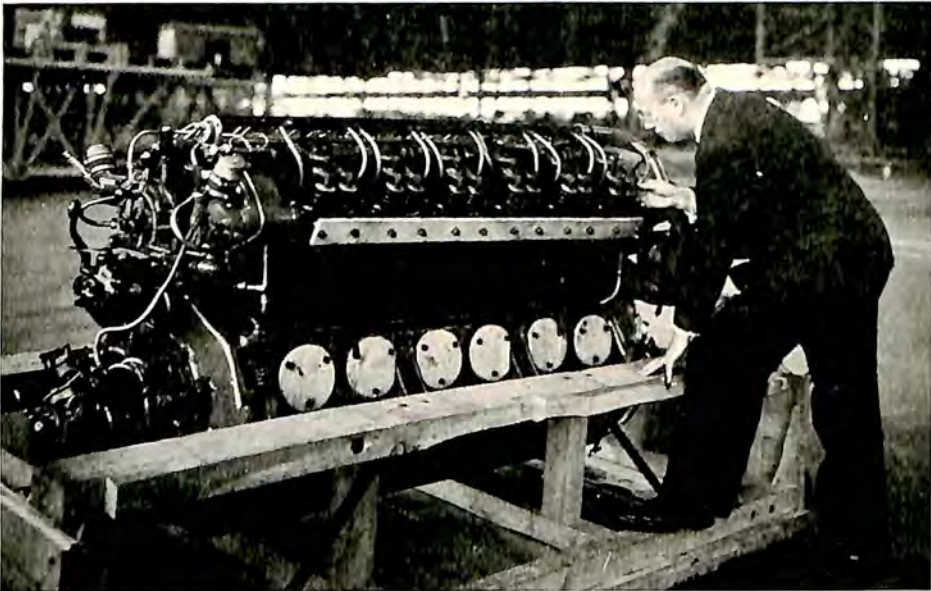

INSPECTS "MACON'S" POWER UNIT

Dr. Karl Arnstein, designer of the "Akron" and "Macon," inspecting one of the 550-horsepower engines for the "Macon."

the spring of 1933, with a gas capacity of 360,000 cubic feet and a gross lift of 22,300 pounds. Its length is 233 feet and its diameter 54 feet. Including the car carried underneath, its height is 69 feet. On each side of the car, a 375 horsepower engine, geared at a ratio of three to two, was mounted with a three-bladed propeller.

Planned for use in coastal patrol work, the TC-13 has five control surfaces instead of the conventional four, mounted in the rear of the ship with one atop the envelope, an elevator on either side and two rudders on the bottom. Space has been provided for three pilots, two mechanics, a navigator, radio operator, bomber, as well as sleeping accommodations, bomb compartment, a sub-cloud car, and a radio set with a 3,000 mile

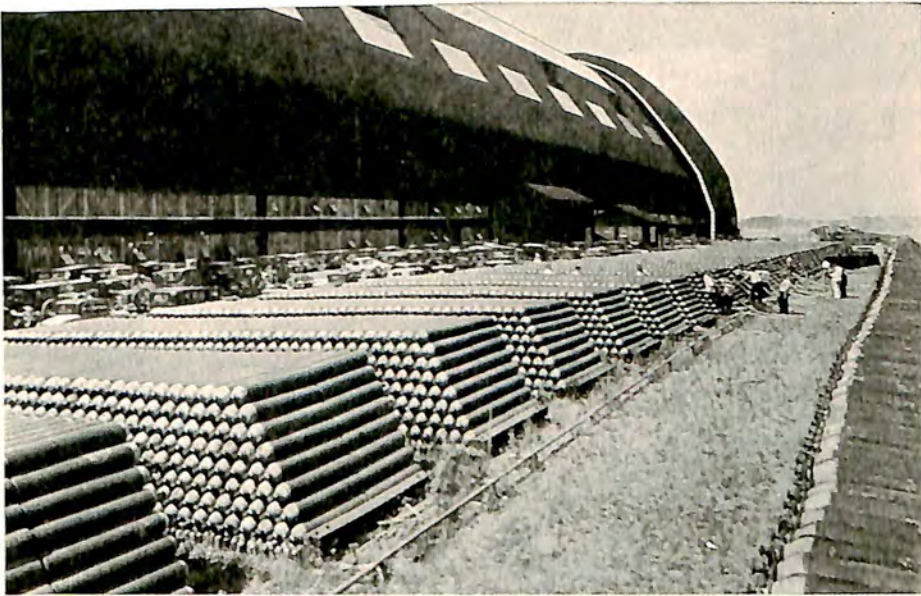

HELIUM FOR THE "MACON"

Thousands of cylinders of helium at the Goodyear-Zeppelin dock in Akron ready to give life to the new airship giant.



NEW AIRSHIP INSTITUTE

Completed in 1932, the new Daniel Guggenheim Airship Institute is opened at Akron as unit of University of Akron.

range. The sub-cloud car, originally designed in the United States by the Army Air Corps, will make it possible for the airship to hide above a bank of clouds, while an observer can descend 1,000 feet in the special car and report his findings by telephone.

The Goodyear fleet of small non-rigid airships, frequently called "blimps," continued to attract attention during 1932 on their flights throughout the country. Five ships were in service, the "Defender" with a gas capacity of 190,000 cubic feet, and the "Volunteer," "Puritan," "Reliance" and "Resolute," each with a capacity of 112,000 cubic feet.

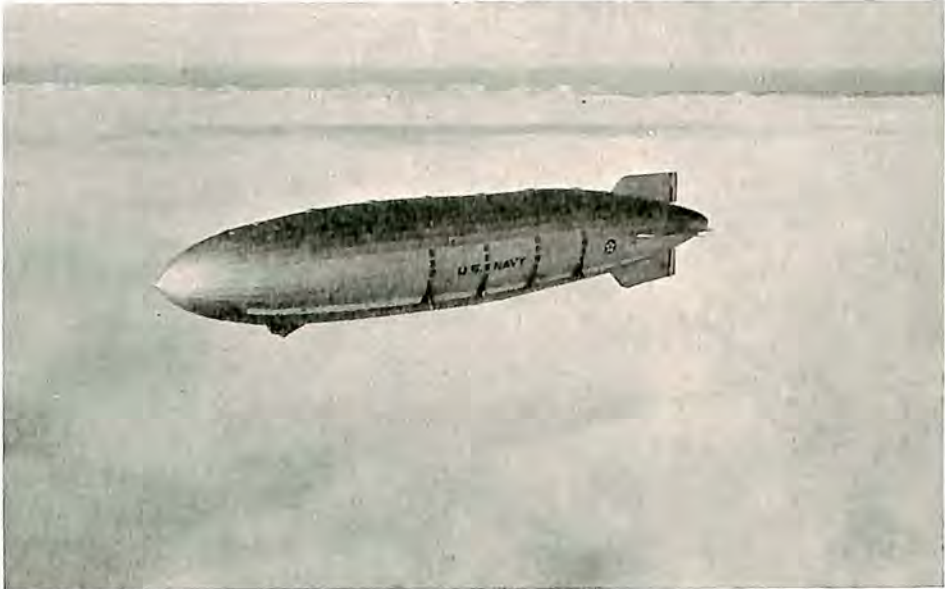

QUEEN OF THE SKIES

Flying over a carpet of clouds, Fairchild Aerial Surveys catch an unusual picture of the airship "Akron."

The "Pilgrim," pioneer of the fleet and having a capacity of only 56,000 cubic feet, made its last flight on December 31, 1931, after a service of seven years and was sent to the Smithsonian Institution in Washington. Its record embraced 4,765 flights totaling 2,880 hours over 94,474 miles with 5,355 passengers.

The fleet of small airships was built primarily to demonstrate lighter-than-air flight and to train personnel in the fundamentals of ship handling, building up a qualified corps to man the giant commercial airships of the future with their cargoes of mail, passengers and express. Goodyear had 25 qualified airship pilots in addition to 100 men trained in the ground and dock handling of ships. During 1932, the "Resolute" was

based at New York, the "Puritan" at Chicago, the "Volunteer" at Los Angeles, and the "Defender" at Akron. Some of the ships operate in Florida during the winter months, returning to Akron in the spring. The fleet had carried more than 100,000 passengers more than 1,000,000 miles without the slightest injury to a single passenger.

Development of a mobile mooring mast mounted to the top of a bus, used for transporting the ground crew from place to place, made possible a considerable extension of the operating range of the non-rigid ships. In previous years, they were forced to remain within cruising range of their



FIVE HOUSED IN "AKRON"

Six of these Whirlwind-powered Curtiss Sparrow Hawks were delivered to the Navy in 1932 for use aboard the airship.

docks. The mast lies flat on the top of the bus and can be raised to receive one of the ships in one minute.

Interested in the possible use of Diesel engines for lighter-than-air craft, Goodyear installed oil burning engines in the flagship of its commercial fleet, the "Defender." Noise and vibration were considerably reduced as a result and fuel economy found to be satisfactory, along with a stepping up of cruising speed. Further tests were contemplated as added improvements can be made to such engines. Development work on Diesel-type engines for airships of the size of the "Akron" and "Macon" was continued during 1932 in both the United States and Europe.

The new year found the Daniel Guggenheim Airship Institute, situated

on the northwest corner of Akron's municipal airport, completed and in full operation after formal dedication of the new laboratory June 26, 1932. A result of the bequest of the Daniel Guggenheim Fund for the Promotion of Aeronautics, the four-story structure housed the world's largest vertical wind tunnel, 60 feet high, as its central equipment feature. The four-bladed propeller fan was designed to create an airstream of 120 miles an hour in the working section of the tunnel.

With the construction of huge Navy airships at Akron, along with plans for commercial airships for use in trans-oceanic traffic, the need for

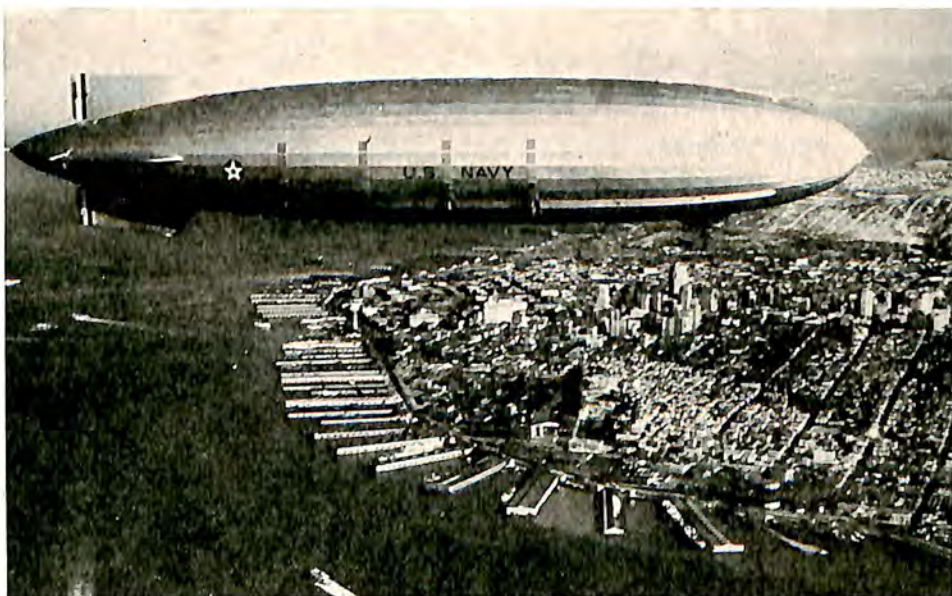

"AKRON" REACHES SAN FRANCISCO

Giant Navy airship over West Coast metropolis at the end of long transcontinental flight to test her ability.

an institute to assist in lighter-than-air research became apparent. The Guggenheim Fund provided a gift of \$250,000, which was supplemented by \$100,000 from the city of Akron. Approximately \$75,000 was expended for the new building and \$50,000 for its equipment. The remainder was to be used to conduct a five year research program. The institute is operated under the supervision of the California Institute of Technology and under the administrative direction of the University of Akron.

The United States demonstrated its continued leadership in balloon racing by winning the third James Gordon Bennett trophy for the third consecutive time, insuring its permanent possession by America. Lieut. Comdr. T. G. W. Settle, chief of the U. S. Navy's inspection staff in the

construction of the Navy's giant airships, scored the victory in the 1932 International Balloon Race at Basel, Switzerland, by remaining in the air 41 hours against an international field of 17 entrants. Ward T. Van Orman, who won the two previous international races, placed second to Settle in the 1932 event by staying aloft 29 hours and landing in Lithuania. Settle landed in Poland, just five miles from the Russian border. The National Balloon Race for 1932 was won by Lieut. W. J. Paul of the United States Army at Omaha, Nebr., but lack of funds kept the Army from entering the international event.

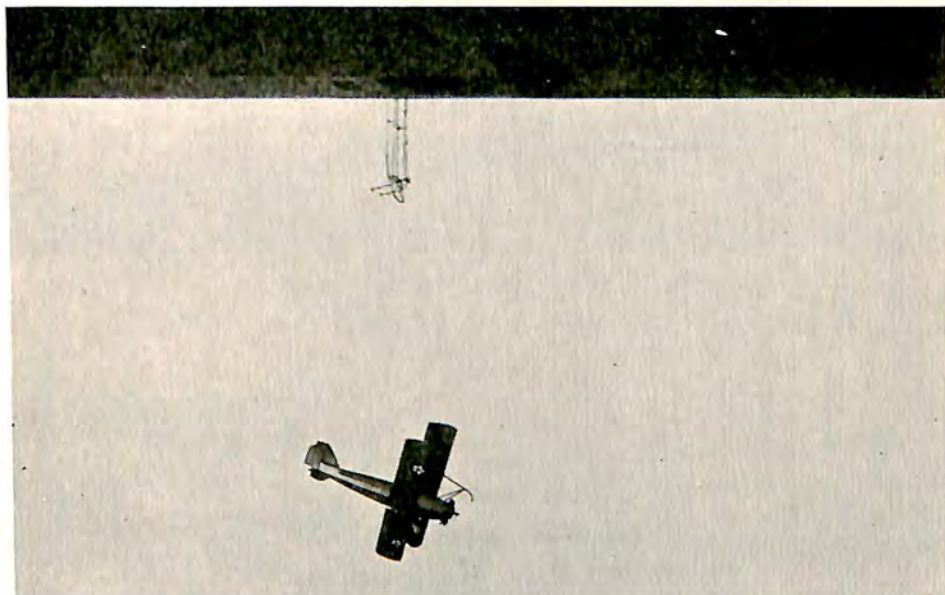

LEAVING "AKRON'S" HULL

Experimental plane leaving the hull-hangar aboard the Navy airship "Akron," showing device for lowering plane.

"Sky advertising" with the use of the Goodyear commercial airship fleet in 1932 opened up a new field of the non-rigid ships' usefulness. Illuminated signs were used at night and long trailing banner signs were employed for daytime flying. Neon signs for night flying, with letters four feet wide and six feet high, were easily discernible at altitudes of 1,500 to 2,000 feet. The daytime banner was made of net with letters six feet wide and eight feet high, the body of each letter being one foot in width. Wind cones kept the 300-foot long trailing signs in position.



BROADWAY ROARS ITS WELCOME

Acme

Amelia Earhart Putnam, first woman to fly the Atlantic, riding up Broadway with Charles L. Lawrence for official welcome.



CHAMBER HONORS MRS. PUTNAM

Acme

Don L. Brown (left) and Bernt Balchen greet Mrs. Putnam, standing with her husband, before Chamber dinner in her honor.

CHAPTER VIII

HISTORY MAKING FLIGHTS OF 1932

World Altitude and Land Plane Speed Records Shattered—Five Planes Carry Twenty-two Persons on Atlantic Flights—"Graf" Makes Eighteen South Atlantic Crossings—Cross-continent Marks Cut

MAN'S conquest of the air pushed the frontiers of aeronautical achievement to a point which left few new laurels for those who seek fame and fortune in the field of history making flights. Although 1933 was to mark only the thirtieth anniversary of man's first successful flight in a heavier-than-air machine, the world already had witnessed many successful flights across the Atlantic and Pacific, to both the North and South Poles, around the world in little more than eight days, across the length and breadth of all the continents, to altitudes of more than eight miles above the earth, for a distance of 5,000 miles non-stop, for duration of more than 84 hours without refueling and 553 hours with the aid of refueling, and at a record speed in excess of 400 miles an hour.

In fact, the opening of 1932 appeared to leave but few blank spaces in Aviation's Roll of Honor for those with a penchant for adventurous flights to fill with their names. Yet the year witnessed some spectacular achievements, which seemed to leave still less room for those whose pioneering or publicity-seeking instincts might prompt to seek a place in the sun.

Fliers seeking a vacant niche for themselves, or one whose occupant seemed a bit insecure in his claim for the pedestal, faced this situation as they surveyed aviation records at the opening of 1932. The world had been girdled in the incredible time of 8 days 15 hours and 51 minutes, a flight made by Wiley Post and Harold Gatty, June 23-July 1, 1931. The North and South Atlantic had been crossed many times in both directions, including 17 successful non-stop flights over the North Atlantic; yet no woman had ever spanned the sea in a solo flight, no solo flight from Europe to America had been successful, no trans-Atlantic flier had made a round-trip, and queerly enough no one had bettered the time of Alcock and Brown, who made the first non-stop crossing in 1919.

If the fame-seeker turned his attention toward the Pacific, he found this entry in the books: Non-stop Pacific flight, Japan to United States, 4,558 miles in 41 hours, by Clyde Pangborn and Hugh Herndon, October 4-5, 1931. Looking to the Arctic or Antarctic: Rear Admiral Richard E.

Byrd with Floyd Bennett as his pilot had reached the North Pole (May 9, 1926) and with Bernt Balchen at the controls flew to the South Pole (November 28-29, 1929). Likewise, the United States had been spanned in 11 hours and 16 minutes by Maj. James H. Doolittle in a transcontinental flight of 2,882 miles, September 4, 1931. Capt. J. A. Mollison held the record for linking Australia and England, 8 days and 21 hours, made July 29-August 6, 1931. London, England, to Cape Town, South Africa, held out its record of 5 days 6 hours and 40 minutes made by Gordon Store and Peggy Salaman, October 30-November 5, 1931.

While "records" were spoken of loosely for flights across continents and oceans, the official world records were for speed, altitude, distance and duration. In these fields, too, the marks at the opening of 1932 had been set pretty high. The Roll of Honor listings read like this: Speed for seaplanes, 406.997 miles per hour by Lieut. George H. Stainforth (Great Britain), September 29, 1931. Speed for land planes, 278.480 miles an hour by Warrant Officer Bonnett (France), June 11, 1924. Altitude for airplanes, 43,166 feet by Lieut. Apollo Soucek (United States), June 4, 1930. Altitude for balloons, 51,775 feet by Prof. Auguste Piccard (Belgium), May 27, 1931. Distance for airplanes, 5,011.8 statute miles in 49 hours and 20 minutes by Russell N. Boardman and John Polando (United States) from New York to Istanbul, Turkey, July 28-30, 1931. Duration without refueling, 84 hours and 32 minutes by Walter E. Lees and Frederick A. Brossy (United States), May 25-28, 1931 at Jacksonville, Fla. Duration with refueling, 553 hours, 41 minutes and 30 seconds by John and Kenneth Hunter (United States), June 11-July 4, 1930, at Chicago, Ill.

The official records not bettered during 1932 were those for distance and duration, both held by the United States, and that for speed with seaplanes, held by Great Britain. Likewise the achievements of Post and Gatty on their speedy world flight, the non-stop spanning of the Pacific by Herndon and Pangborn, and Byrd's dashes to the North and South Poles were not duplicated during 1932.

However, successful bids were launched during the year to be the first woman to span the Atlantic non-stop in solo flight, to be the first solo flier to make a crossing from Europe to America, to raise the world's speed record for land planes, to boost the world's altitude record for airplanes and balloons, and to shatter all speed marks for flights across the United States, between England and Australia, and from London to Cape Town. The 'round-the-world mark set by Post and Gatty was the object of one record-shattering attempt, which fell short of its goal; and the world's speed record for seaplanes was the mark shot at by another which met with unofficial success, but was not recognized. It should be interesting to relate briefly the stories of these history making flights of 1932.

With her eyes firmly fixed on the vacant niche in Aviation's Hall of Fame marked "First Woman to Span Atlantic Non-stop in Solo Flight," Amelia Earhart Putnam, America's leading woman flier, quietly laid her plans for a flight from New York to Paris in the Spring of 1932. May 20th, just five years to the day from the time Charles Augustus Lindbergh took off on his flight from New York to Paris, found the tall, lithe, blond-haired woman flier climbing into her red and gold Wasp-powered Lockheed Vega monoplane at Harbor Grace, N. F. A few minutes later, after shaking hands with Bernt Balchen, who supervised her preparations, and Eddie Gorski, her mechanic, she took off alone and was soon lost from sight flying eastward over the Atlantic.

Without fuss or advance publicity, she had flown from Teterboro Airport, Hasbrouck Heights, N. J., the previous afternoon with Balchen at the controls for the preliminary hop to St. John, N. B., and then on to Harbor Grace. Not even her closest friends knew of her plans.

She knew something of what she might expect on the Atlantic crossing from her flight as a passenger several years earlier in the Whirlwind-powered Fokker "Friendship" which crossed the Atlantic to Wales. That flight was instrumental in her meeting the publisher, George Palmer Putnam, who brought out her first book "20 hrs. 40 min." It also led to their marriage in 1930. Now, Husband Putnam was spending an uneasy hour in a New York hotel while his wife was far out over the Atlantic.

Little did he know that she was finding advance reports of good weather entirely wrong, that for the first time in her experience as a pilot her altimeter was acting up, and that a broken exhaust ring was causing some uneasy moments. It was not until early the next afternoon that these facts became known when she sighted an inviting pasture, landed, and found that she was on a farm near Londonderry, Ireland. The flight from Newfoundland to Ireland had been completed in 15 hours and 18 minutes, for the first time bettering the 13-year-old record of Alcock and Brown, and assuring her the distinction of being the first woman to span the Atlantic in solo flight, although she was short of her Paris goal.

Asked, by enthusiastic British admirers at Hanworth Airdrome, near London, on the following day: "Just why did you do it," Mrs. Putnam replied: "Oh, just for the fun of it." Her enterprising publisher-husband, learning of the remark, announced that he would soon publish a book by his wife, written before her departure, entitled "The Fun of It."

In the meantime, the capitals of Europe were acclaiming the latest exploit of America's premier woman flier. She was the guest of Ambassador Andrew W. Mellon at the American Embassy in London, just as Lindbergh had been Ambassador Herrick's guest in Paris. France be-

stowed the Cross of the French Legion of Honor. Rome lionized her. King Albert of Belgium personally presented her with the insignia of Chevalier of the Order of Leopold. On June 14, Mrs. Putnam left Paris for home and New York's ticker-tape welcome ordained for returning heroes. Charles L. Lawrance, president of the Aeronautical Chamber of Commerce, headed a committee of 150 who greeted her for the parade up Broadway to receive the city's official honors from Mayor James J. Walker.

The Aeronautical Chamber of Commerce fêted her at a banquet in the Waldorf-Astoria on the evening of her return, adding her name to the very limited list of famous fliers honored by the Chamber: Lindbergh, Byrd, Post and Gatty. President Hoover presented the special gold medal of the National Geographic Society on the following day. Congress voted her a Distinguished Flying Cross, and Vice President Curtis presented it at the Olympic Games.

First East-to-West Solo Atlantic Flight

British fliers had shown little interest in recent years in striking out across the Atlantic as Americans had done time after time in their bids for aviation fame. The route from England to Australia and from England to South Africa had proved more attractive to them and their light low-horsepowered planes. One of the greatest of the lot of British fliers who burned up the airways on the Empire routes was a Scot, Capt. James Allan Mollison, former pilot in the Royal Air Force. The lure of the Atlantic, and the opportunity of becoming the first to fly solo from Europe to America and to make a round trip flight—neither of which had been achieved—finally snared him.

After waiting impatiently eight days for favorable weather reports, Mollison took off from Portmarnock Strand, near Dublin, Ireland, on August 18 and headed westward in his tiny de Havilland Puss Moth (Gipsy) cabin plane "Heart's Content." Named for the little Newfoundland peninsula which he expected to sight as the first point of land and not for his bride of three weeks, Amy Johnson Mollison, the diminutive plane faced headwinds from the start. Mollison had had oversize fuel tanks, capable of holding 162 gallons of fuel, installed to feed his 120 horsepower engine and to obtain what he expected would be a 120 miles per hour speed for 3,300 miles cruising.

Sighted twice by steamships on the Atlantic crossing, he passed over Heart's Content, N. F., in the dark, pushed on to Harbor Grace. Estimating his fuel as sufficient to carry him directly to New York, he flew on, circling Halifax, and continuing on down the coast. Fog and the uncertainty of his dwindling gasoline supply in the face of headwinds forced him

to land at Pennfield Ridge, near St. John, N. B., too tired to go on. On August 21, he flew on to Roosevelt Field, L. I., N. Y., circling New York City for a view of the skyscrapers, before landing. He had achieved his ambition to be first pilot to fly solo from East to West, now it remained for him to make the first round-trip flight.

After several days rest in New York during which his engine was tuned up, he took off for the return flight and reached St. John, N. B., without incident. En route to Harbor Grace the next day, he was forced down at Sydney, N. S., by bad weather, and before he got into the air again



BIG YEAR FOR MOLLISONS

Amy Johnson Mollison, who broke London-Cape Town record, and her husband J. A. Mollison, who spanned the Atlantic in 1932.

he was pronounced nervously exhausted by a physician. Pleas from his wife finally induced him to abandon his round-trip effort and return to England by steamer, which he did, leaving Montreal September 3. His failure to carry out the entire program in no way dulled the spirit of his enthusiastic reception in London.

It was the second time during 1932 that he had been the center of attention in England as the result of an outstanding flight. Having already set the record for the fastest flight from Australia to London, in 1931, Mollison turned toward the England-South Africa route. In March, 1932, he flew from Lympne, England, to Cape Town, South Africa, in his little de Havilland Puss Moth (Gipsy III) in 4 days, 17 hours and 19 minutes

to lower the 1931 mark of 5 days, 6 hours and 40 minutes made by Peggy Salaman and Gordon Store.

Not to be outdone by her husband, Amy Johnson Mollison began preparations for a flight to South Africa as soon as her husband returned from his Atlantic exploit. Taking off from Lympne, England, November 15, she sped south in her tiny de Havilland Puss Moth (Gipsy), courageously cutting directly across the Sahara Desert to make certain that she would lower her husband's record. With only five hours sleep for the whole trip, she arrived in Cape Town after clipping 10 hours and 26 minutes from



DO-X SPANS NORTH ATLANTIC

Dornier DO-X, powered with 12 Curtiss Conqueror engines, flying near New York City with 106 persons aboard before Atlantic hop.

Mollison's time. "Great Work Amy" her husband wired, and she hurried preparations for a homeward flight over practically the same route, arriving in London with a South-North record of seven days, seven hours and five minutes.

Mollison's chief contender for the England-Australia route honors was C. W. A. Scott who had his own record for the West-to-East flight snatched from him by C. A. Butler in November, 1931, when Butler made the trip in 9 days, 2 hours and 29 minutes. Scott regained his record in April, 1932, when he flew a de Havilland Moth (Gipsy) from Lympne, England, to Port Darwin, Australia, 11,000 miles, in 8 days, 20 hours and 47 minutes.

This was even faster time than Mollison's record from East-to-West of 8 days and 21 hours, which remained unbroken during 1932.

Fourteen Fly Atlantic in Do-X

In striking contrast to Mollison's flight in a tiny airplane powered with a 120 horsepower engine was the homeward flight of the giant Dornier Do-X with its 12 American-made Curtiss Conqueror engines providing 7,800 horsepower. The lights which gleamed from her cabins and reflected on the waters of Long Island Sound in the early morning of May 19 told of the activity aboard in preparation for the Atlantic flight. With a working crew of 13 and Fraulein Antoine Strassman, German woman flier, who was listed as "assistant purser" because no passengers were allowed, the big ship took off before dawn upon signal from Capt. Friedrich Christensen and headed for Holyrood, N. F.

Laden with 7,000 gallons of gasoline and a total load equal to 260 passengers, Chief Pilot Mertz pulled the huge flying boat up off Newfoundland's waters the following day on the second lap of the journey. That night, with its great fuel supply virtually gone, the pilot "felt" the giant plane down onto the black surface of the sea, cutting the engines as the hull struck the water. They were six miles off Horta in the Azores. The next lap to Vigo, Spain, made on the following day, was easy.

Five days after leaving New York, the big boat settled down onto Southampton water just off the Calshot Air Station, narrowly averted serious damage when it drifted toward the breakwater. Germany accorded the Do-X a tremendous welcome when it was landed on Mueggel Lake, near Berlin, May 24. The great flying boat had been away from Germany 19 months on its cruise to points in Europe, Africa, South and North America, including a non-stop flight across the South Atlantic with 13 persons aboard and its later North Atlantic flight with 14.

First Non-Stop Flight to Berlin

With their eyes fixed on far more than the conquest of the Atlantic, James Mattern and Bennett Griffin took off from New York's Floyd Bennett Field before dawn July 5 in their Wasp-powered Lockheed Vega monoplane "Century of Progress" and headed for Harbor Grace as their first point of call. Their hearts were set on nothing less than the remarkable eight-day record of Wiley Post and Harold Gatty for a flight around-the-world.

They lost little time at Harbor Grace, headed eastward along the Great Circle course. Eighteen hours and 41 minutes later they set their wheels down on Templehof Airdrome in Berlin, having made the first non-stop

flight from North America to Berlin and already many hours ahead of Post and Gatty's time. Spending little more than three hours in the German capital, they headed for Moscow, 10 hours ahead of the record time.

Soon after they reached the Russian border, a hatch flew off injuring one of the tail surfaces. They decided to make a landing in the dark. They sighted what appeared to be a pasture and set their speedy plane down. A few seconds later they were helping one another out of the wrecked plane. They had landed in a peat bog. Their hopes for a world record went aglimmering as they examined the damaged plane, beyond



Wide World

HARBOR GRACE TO BERLIN NON-STOP

Mattern and Griffin land at Templehof Airdrome, Berlin, in their Wasp-powered Lockheed after trans-Atlantic flight.

hope of immediate repair. Berlin papers hailed their great non-stop flight to Germany, pointed out that their time over the Atlantic, about 11 hours, was the fastest crossing yet made.

Von Gronau Completes World Flight

Flying the Atlantic had become commonplace to Capt. Wolfgang von Gronau by 1932, when he made his third flight from Europe to North America via the sub-Arctic route in as many years. Consequently, he decided to continue his 1932 flight by easy stages around the world.

In many ways Capt. von Gronau's 1932 Atlantic crossing resembled those of 1930, when he flew to Chicago after landing in New York's busy

harbor off the Battery, and 1931, when he went to Chicago via Canada. Each flight originated on the Isle of List in the North Sea, off Germany's coast. All three flights were made in B. M. W.-powered tandem-motored Dornier Wal flying boats. In 1930, it was the five-year-old craft which Amundsen and Capt. Frank Courtney had used, and which finally found a place in a Munich museum. In 1932, as in 1931, he used a newer ship named "Groenland-Wal," meaning "Greenland Whale." His crew each year consisted of three men from his List flying school. Franz Hack, mechanic, and Fritz Albrecht, radio operator, made all three flights. In



VON GRONAU GIRDLES WORLD

Capt. Wolfgang Von Gronau at Transamerican Airlines' Detroit base during repair of his B.M.W. engines on world flight.

1932, Gert von Roth, a teacher, replaced Eduard Zimmer, student, as co-pilot. While the first crossing took nine days, the 1932 passage was made in five. His 1931 and 1932 flights were sponsored by the Deutsche Luft Hansa, ostensibly to survey the sub-Arctic route and lay a German claim to pioneering that passage for later commercial operations.

Leaving Germany July 22, von Gronau and his crew arrived at Reykjavik, Iceland, July 24 and pushed on to reach Montreal July 26. On his way to Chicago, he was forced down on Lake St. Clair and was towed to the Transamerican Airlines' marine air base at Detroit for repairs to his German engines. Chicago received him for the third year, August 2. Flying across Canada by way of Winnipeg, the party reached Prince Rupert,

B. C., August 18, and Juneau, Alaska, August 22. Skirting the Aleutian Islands, the plane landed in Tokyo, September 4; Shanghai, September 25; Manila, September 27; Rangoon, October 11; Ostia, Italy, November 7; and received a great ovation at Friedrichshafen, Germany, November 10. With characteristic German thoroughness, von Gronau expressed a desire to leave the round of banquets he was enjoying to complete the last stage of the world flight, from Friedrichshafen back to List, the starting point. He reached List November 23.

Summing up the year's flights across the Atlantic, five planes successfully made the crossing carrying 22 passengers. However, the year was not without its abortive attempts. Three planes, carrying a total of ten passengers, were forced down and their occupants rescued. Three others with a total of five persons were lost at sea, and one ship with two aboard crashed before it headed out over the sea, its occupants escaping injury. Late in the year, the Department of Commerce issued a ruling forbidding any trans-oceanic flights made without specific permission from the Department, which would be granted only after ship and pilots would be thoroughly examined, preparations checked, and all diplomatic arrangements with foreign governments completed.

The three parties rescued were: Lou T. Reichers, 47 miles off Fastnet, Ireland, by "S.S. President Roosevelt" on attempted solo flight from New York to Paris in a Cyclone-powered Lockheed Altair; Stanislaus F. Hausner, 550 miles west of Portugal, by a tanker, on attempted solo flight from New York to Warsaw, after floating eight days in a Whirlwind-powered Bellanca; and the "Flying Family" of Hutchinsons—George, 30, Blanche, 28, Kathryn, 8, Janet Lee, 6—and a navigator, radio operator, mechanic and photographer, by a British trawler, off the coast of Greenland, on attempted flight by easy stages from New York to London in a Wasp-powered Sikorsky 38.

The two planes lost at sea were: "American Nurse," a Wasp-powered Bellanca, carrying William Ulbrich, pilot, Dr. Leon M. Pisculli and Edna Newcomer, a nurse, on an attempted flight from New York to Italy; and a Whirlwind-powered Stinson, carrying Clyde A. Lee and John Bohkon, on an attempted flight from Harbor Grace to Oslo, Norway. Another attempted flight to Oslo ended prematurely when Thor Solberg and Carl Petersen, flying a Hornet-powered Bellanca, to Harbor Grace, N. F., struck the water with a wing at Darby Harbor, N. F., in attempting to avoid a cliff. None was injured.

The only West-to-East Pacific flight of the year ended in disaster with the disappearance of the three Japanese fliers, Eichiro Baba, pilot, Kiyoshi Homma, navigator, and Tomoyoshi Inoshita, radio operator, in an attempted flight from Samushiro, Japan, to Nome in a Junkers-powered Junkers W-33 monoplane.

Flying the Atlantic was just an every-day occurrence for the veteran "Graf Zeppelin" in 1932. The great German airship, presaging what might be expected of the projected American super-airships for trans-oceanic passenger travel, continued its flights with the regularity of a veteran sea-going liner.

Nine round-trips were made with mail and passengers during 1932 between Friedrichshafen, Germany, and Pernambuco, Brazil, on a carefully prearranged schedule. The 18 South Atlantic crossings were made on schedules maintained with almost perfect regularity, the only delays being



NEW ENGLAND-AUSTRALIA RECORD

C. W. A. Scott being greeted by his father and mother in England after record flights to Australia and return.

caused by unfavorable launching conditions at Friedrichshafen. Both delays were overcome during the voyage, so that the next schedule started on time.

During the year, the airship made 58 cruises, flew 112,336 miles, carried 1,218 passengers, 6,052 pounds of mail, and 4,456 pounds of freight. In addition to members of the crew, the ship accommodated 22 or 23 passengers on each flight, depending on the passengers' weight.

The flight to Brazil was scheduled to take 72 hours and the return trip, 96. The year's averages actually were 71 hours and 51 minutes, and 86

hours, respectively. On the fastest Germany-bound flight, the airship required only 67 hours for the trip. Through a hook-up with Luft Hansa's air line service in Germany and the Condor Syndicate in Brazil, Berlin mail on one trip was able to reach Rio de Janeiro four days after posting.

British Capture World Altitude Record

While airplanes and airships were hurdling oceans, several of the world's most coveted records were changing hands. Great Britain wrested the world altitude mark for airplanes from the United States, holder of the title for so many years that America felt it had almost a permanent claim to it. The United States abandoned its record altitude program in 1930 after Lieut. Apollo Soucek of the U.S.Navy boosted the mark to 43,166 feet, and sent its high-flying naval lieutenant to sea with the fleet.

In the Spring of 1932, word came from England that the British were secretly attempting to beat the American's world record. Finally, on September 26, after several attempts, news came that Capt. Cyril F. Uwins had flown a Vickers Vespa (Bristol Pegasus) to a new altitude record of 43,976 feet at Filton, England. He climbed until his fuel gave out, glided to a safe landing in a plowed field.

But the highest point yet to be reached by man above the earth's surface had been accomplished not by an airplane, but a balloon. Prof. Auguste Piccard had navigated his balloon CH-113 into the stratosphere to study cosmic ray phenomena in 1931, reaching a height of 51,775 feet. The Belgian professor boosted that mark further in 1932 when he made an ascension to 53,152 feet, the highest point ever reached by man.

In another field of lighter-than-air navigation, the United States captured world laurels by winning permanent possession of the Third Gordon Bennett Trophy, symbol of three consecutive American victories in the international balloon classic. Lieut. T. G. W. Settle, pilot, and Lieut. Wilfred Bushnell, aide, of the U.S.Navy scored the 1932 victory against 16 contestants at Basel, Switzerland. Ward T. Van Orman, twice winner of the Gordon Bennett trophy, and his aide, R. L. Blair, landed only a relatively few miles short of the distance set by the other American team. In the National Balloon Race for the Litchfield Trophy, the U.S.Army team of Lieut. Wilfred J. Paul and Lieut. John H. Bishop was victorious over a field of six contestants who took off from Omaha, Nebr., May 30, as a feature of the Omaha Air Races. Their mark was 901.4 miles, landing in Canada.

United States Recaptures Speed Record

Partially offsetting its loss of the world's altitude record for airplanes, the United States regained title to the world's speed record for land planes,

lost to Warrant Officer Bonnett of France, June 11, 1924, when the French flier averaged 278.480 miles an hour for the measured course.

Maj. James H. Doolittle brought the record back to the United States September 3 when he flew a Wasp-powered Gee Bee Super-Sportster at an average speed of 296.287 miles an hour over a measured course during the National Air Races at Cleveland. Originally built for Russell M. Boardman, who was injured in an airplane mishap shortly before the races, the plane was finally offered to Major Doolittle, who said he had "left a few more miles in her for Russell to get out."



WIN NATIONAL BALLOON RACE

Sen. Hiram Bingham congratulates Lieut. W. J. Paul, pilot, and Master Sgt. J. H. Bishop, aide, on winning national race.

The world's premier speed record—that for seaplanes—remained in Great Britain's hands, although Italy made a determined bid for it in 1932. Lieut. Ariosto Neri was credited on June 16 with an unofficial speed of 430 miles an hour, considerably greater than Lieut. Stainforth's 406.997 miles an hour. However, the Italian flier's mark was disqualified when the rudder broke loose and the pilot was forced to make an emergency landing. He was killed September 6, before another attempt at the world record was made.

While the United States continued to hold its grasp on the world's records for straight-line distance and duration, both with and without refueling, France raised the closed-course distance record another peg when

Lucien Bossoutrou and Emil Rossi flew 6,575 miles in 76 hours and 35 minutes, March 23-26, at Oran, Algiers. The previous mark of 6,445 miles was held by Joseph Le Brix and Marcel Doret of France. The new record was made in a Bleriot 110 (Hispano-Suiza).

Both Transcontinental Records Broken

While Major Doolittle was preparing for his successful onslaught against the world's speed record for land planes, an old transcontinental speed mark which he cherished was wrested from him by James H. Haizlip, who streaked across the continent from Burbank, Cal., to New York's Floyd Bennett Field in 10 hours and 19 minutes, cutting 57 minutes from Doolittle's time for the West-to-East flight. Haizlip's performance, made August 29, carried with it victory in the Bendix Trophy Race, offered for the fastest time from Los Angeles to Cleveland during the National Air Races. He used a Wedell-Williams (Wasp Jr.) low-wing monoplane.

Close behind Haizlip on that momentous evening came Roscoe Turner, also bettering Doolittle's time, but 39 minutes too slow to nose out Haizlip for the trophy and transcontinental honors. Nevertheless, Turner came into his own November 14, when he made a new record of 12 hours and 33 minutes for the East-to-West transcontinental flight from New York's Floyd Bennett Field to Burbank's United Airport, bettering an earlier mark of 14 hours and 50 minutes made by the then Capt. (now Comdr.) Frank M. Hawks. Turner, like Haizlip, used a Wedell-Williams (Wasp Jr.) low-wing monoplane.

Commander Hawks, who for years made a specialty of having breakfast and dinner on opposite ends of continents, opened 1932 with a flight from Agua Caliente, Mexico, to Vancouver, Canada, and return in 13 hours and 44 minutes, using his famous Whirlwind-powered Travel Air "Texaco 13." His northbound trip was made in 6 hours, 52 minutes and 45 seconds. Hawks' style was cramped considerably, however, when he wrecked his plane in April while attempting to take off from a short dirt road on the Worcester (Mass.) Airport. His jaw was broken and his familiar smile stilled for several months. The close of the year found him taking delivery on a new 14 Cylinder Whirlwind-powered Northrop all-metal low-wing monoplane, determined to burn up the airways and get his old records back in 1933.

Another of Major Doolittle's inter-city records to fall during the year was that for a flight from Ottawa, Canada, to Mexico City, Mexico, with a stop in the capital of the United States. James R. Wedell of New Orleans, flying one of his Wasp-powered racers, made the three-capital flight, October 23, in 11 hours and 53 minutes for the 2,500 miles. His time was 53 minutes faster than Doolittle's 1931 mark. Many other inter-

city flights at high speed, too numerous to review, were made by many pilots. Attention also is called to the complete results of the 1932 National Air Races, including the Thompson Trophy Speed Classic, in Part III of this volume, "Aviation Chronology and Records."

American women pilots raised the unofficial world's records for women in speed, distance, altitude, and duration with the aid of refueling during 1932. However, none of the marks set by women surpassed the official records, all of which had been made by men. The most important women's records made during the year will be found in the day-to-day diary of



SETS NEW TRANSCONTINENTAL RECORD

Col. Roscoe Turner and the Wasp-powered Wedell-Williams speed plane in which he broke the East-West coast-to-coast mark.

important aviation events during the year in Part III of this volume, "Aviation Chronology and Records."

Aside from the always inviting opportunity to better existing records or repeat outstanding flights, already achieved, in faster time, the 1933 pilot seeking new laurels could find only one niche yet unfilled: "First Pilot to Successfully Complete Round-trip Trans-Atlantic Non-stop Flight." It is likely that this niche might collect quite a bit of dust before it becomes filled, since achievement of the feat would be little more than a "stunt" and just so much exhausting punishment for the pilot. The new Department of Commerce regulations also were likely to keep American pilots from becoming too eager for the "honor."

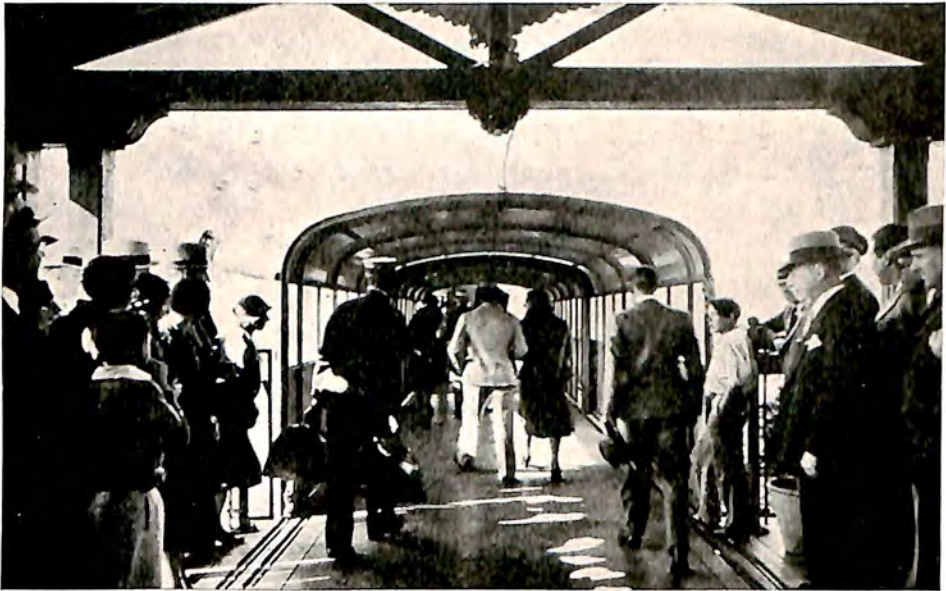

TELESCOPIC RAMP TO PLANE

Protection of passengers from wind, dust and weather is provided at United Airport by this covered passageway to planes.



FRIENDLY LIGHTS AT NIGHT

Lights of United Airport at Burbank, Cal., gleam a friendly greeting to the ever-growing list of night passengers.

CHAPTER IX

AIRPORTS: HARBORS OF THE SKY

New Ports Established or Existing Terminals Improved in Twenty-eight States—Aviation and Utility Interests Cooperate On Advance Planning—Newark Holds Traffic Lead—Statistics in Annual Survey

ALTHOUGH the nation's total expenditure for construction, maintenance and operation of airports in 1932 was only half that of the preceding year, municipalities and private initiative continued the leadership of the United States in providing the world's greatest network of airways and sky harbors for the air travelling public. The air line passenger, private and industrial flier, and military pilot all utilized the increased facilities provided through the expenditure of nearly \$5,000,000 for the construction of new terminal buildings, hangars and lighting equipment as well as the addition of greater landing area and more surfaced runways.

While the annual survey of the Airport Section of the Aeronautical Chamber of Commerce of America showed that some airports, both municipal and commercial, had been abandoned, either because of adverse economic winds, poor location or lack of activity, it was known that 41 new municipal airports and 28 commercial ports were established or opened during 1932. This did not include 91 other fields, given an auxiliary rating by the Department of Commerce, which were established either by state, municipal or private initiative. Twenty-eight states were the scene of this activity during 1932.

Strict economy, forced by decreased revenues, resulted in the slashing of municipal appropriations for new airport construction and expansion and caused the total amount spent by municipal and private enterprises for new construction to fall below the \$5,000,000 mark for the first time in three years. The amount spent was actually \$2,500,000 less than had been planned in appropriation estimates drawn up at the close of 1931. It also was about \$9,000,000 less than the amount spent for new construction in 1931, which was a banner year. The fact that many major airport projects had been completed also contributed to the drop in new construction. Many cities included airport construction in their unemployment relief

programs. The Chamber's survey placed the total amount spent for expansion work in 1932 on the nation's 750 leading municipal and commercial airports at \$4,478,886, an average of \$5,971 per airport. Estimates for 1933 construction were reported at \$1,063,200, representing a still further drop for the new year.

Expenditures for maintenance and operation remained at approximately the 1931 levels for most major airports, although the reports indicated that \$4,500,000 was spent for this purpose, representing a decrease of \$850,000 from 1931 figures. The amount spent was about \$1,500,000 more than was



CATALINA'S AIRPORT RAMP

Whirlwind-powered Douglas Dolphins and Cyclone-powered Keystone Air Yachts on the ramp and turn-table at Catalina Island.

anticipated in pre-year estimates. Estimates for 1933 indicated that airport managers planned to cut a total of \$325,000 from their 1932 budgets, estimating their total expenses for maintenance and operation in 1933 at \$4,187,006.

The total number of airports of all kinds recognized by the Department of Commerce at the close of 1932 was 2,079. Of these 547 were municipal airports, 619 were commercial ports, 350 were intermediate fields, 459 were marked auxiliary fields, 50 were Army air bases, 14 were Navy air bases, and 41 were government, state or private fields. Alaska had 72 fields, two of which were lighted for night flying. Eleven major airports had night lighting equipment installed during 1932, bringing the total in the United



RUNWAYS ARE LENGTHENED

Runways of the Glenn Curtiss Airport at North Beach, L. I., N. Y., were improved as part of 1932 program.



KANSAS CITY AT NIGHT

Wasp-powered Ford of Transcontinental and Western Air arriving at the Kansas City Municipal Airport from the west.

States completely equipped with lighting for night flying up to 691. More than 90 per cent. of the world's lighted airports were located within the continental limits of the United States. The nation's splendid facilities for night flying accounted for the rapid expansion of 24-hour day flying operations of the air lines with passengers, mail and express. Night flying took air transport out of the auxiliary service class and made it a national transportation system.

The Airport Section of the Aeronautics Branch of the Department of Commerce continued its program for rating airports and encouraging the



HUGE TWA MAINTENANCE BASE

Built at a cost of \$300,000, this central operating and maintenance base of TWA was completed in Kansas City in 1932.

development of first class ports, 12 airports being given new ratings during the year. A new transport rating for airports, known as A-T-A, was established to designate those ports ideally prepared to meet the needs of air line operation on a large scale. Four airports had received this rating by the close of 1932: Birmingham Municipal Airport, first to receive the new designation; Wayne County Airport at Detroit, Mich.; Oakland (Cal.) Municipal Airport; and Lambert-St. Louis Field at St. Louis, Mo. Airports added to the growing list to receive A-T-A ratings included: the Douglas (Ariz.) International Airport and municipal airports in Minneapolis, Minn.; El Paso, Tex.; Detroit, Mich.; Tulsa, Okla.; Akron, O.; Buffalo, N. Y.; and Houston, Tex. Parks Airport at East St. Louis, Ill.,



PITTSBURGH'S NEW TERMINAL

As passengers arriving at Pittsburgh see the new Allegheny County Airport passenger terminal opened during 1932.



BUSY DAY AT BIRMINGHAM

Passenger terminal, styled after Mount Vernon, and new hangar on the Birmingham, Ala., Municipal Airport seen from the air.

obtained an A-2-X rating and the Municipal Seaplane Base at West Palm Beach, Fla., was given a D-2-X rating. More than 700 municipalities utilized the advisory service of the Department of Commerce during 1932 on problems of airport site selection or details of construction programs for future planning.

Realizing the importance of future planning in conjunction with the selection of airport sites and plans for their expansion, the Airport Section of the Aeronautical Chamber of Commerce devoted a major share of its attention during 1932 to working out an agreement with power and utility



OKLAHOMA CITY AIR TERMINAL

Modern passenger terminal dedicated in 1932 on Oklahoma City's Municipal Airport, with TWA plane on concrete apron.

interests which would make it possible for aviation and utility executives to give each other advance notice of airports planned or utility programs projected which might include serious obstructions to air navigation. The work was being carried on through the American Committee for the Marking of Obstructions to Air Navigation, created to include associations and representatives of all interests concerned with the problem. The several sections of the Aeronautical Chamber of Commerce had half of the total voting members on the Committee. It was hoped that through such advance planning airport projects would not be located in areas involving major utility developments such as radio towers and high tension lines and that utility interests, in turn, would cooperate by not erecting obstructions

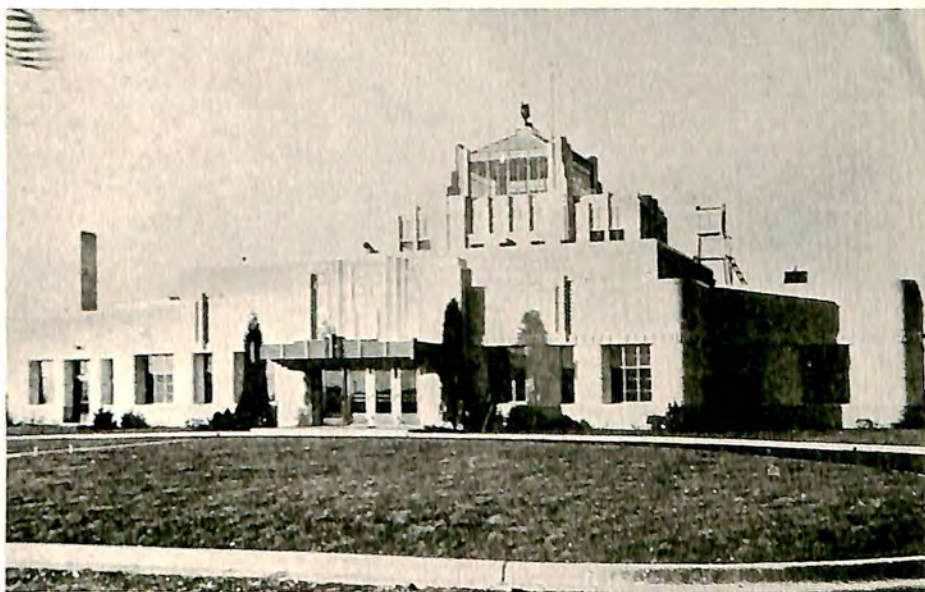

TULSA'S ATTRACTIVE TERMINAL

Judged one of the finest air passenger terminals in the Southwest, this modern building is on Tulsa's Municipal Port.

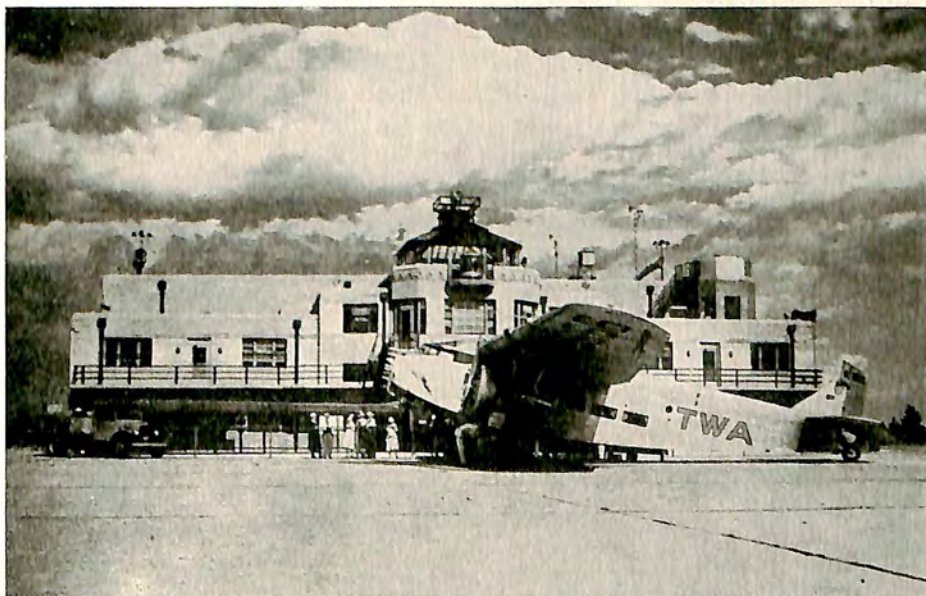

INDIANAPOLIS' TRAFFIC INCREASES

With new schedules added and routes opened, Indianapolis' passenger terminal has become an important center.

to air navigation near existing airports and airways. The Chamber's Airport Section did not hold its annual National Airport Conference in 1932, because of the expressed desire of member airport managers to cut travel expenses, but such a conference was planned for 1933.

One of the outstanding construction projects reported to the Aeronautical Chamber of Commerce in its survey of 100 representative airports was that which had been launched by the City of New Orleans (La.) on Lake Ponchartrain. Built of fill surrounded by a retaining wall, the new airport was to be dedicated early in 1933 for the use of both land and



SUNDAY IN LOUISVILLE

Typical Sunday crowd at Kentucky's chief air center, Bowman Field in Louisville, with new hangar in background.

seaplanes. Four runways, ranging from 3,600 to 4,000 feet in length, and several buildings, including a large terminal of Spanish Renaissance architecture, were features of the new port.

The Oklahoma City Air Terminal, a municipal project dedicated April 1, 1932, was another new airport representing an expenditure of \$500,000, which included the cost of the land, engineering and inspection, installation of a drainage and sewer system, runways, water supply system, lighting, grading, a \$53,000 terminal and administration building, 120 by 120 foot hangar, fencing, motor drivers, aprons and taxi strips and landscaping. It indicated what cities planning new airports might obtain at reduced costs made possible by economic conditions.



GRAND CENTRAL AT GLENDALE

As the air passenger sees the mission terminal building and runway of the Grand Central Air Terminal at Glendale, Cal.

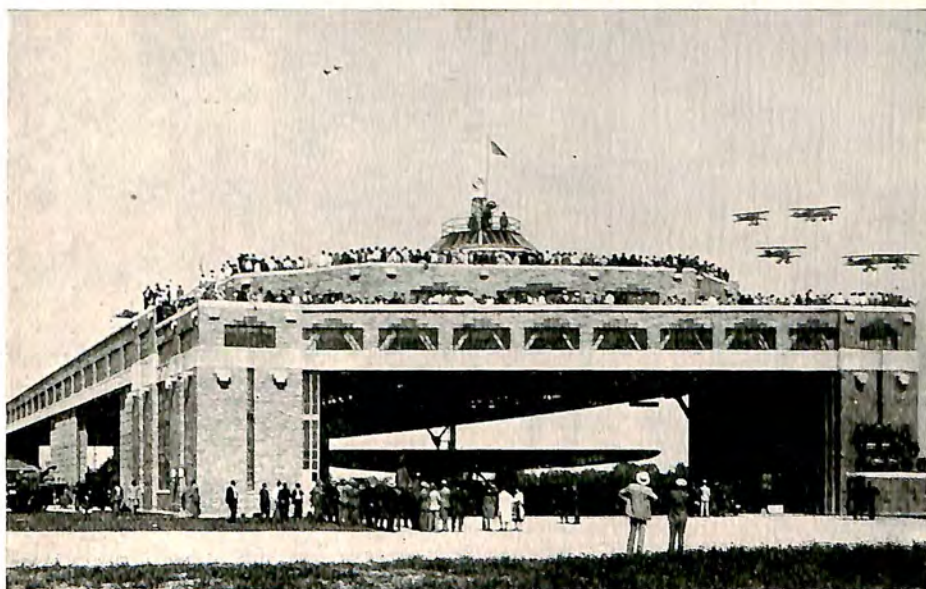

WAYNE COUNTY ON GALA DAY

Crowds attracted by a special flying program on the roof terraces of the main hangar at Wayne County (Mich.) Airport.

The year's improvements throughout the country included the addition of about 2,500 acres of land to existing or new ports, the extension or installation of runways on more than 100 airports, the installation or improvement of lighting equipment at 75 fields; and the construction of approximately 100 hangars of all sizes. Several new terminal buildings were completed and landscaping projects carried out.

Lindbergh Field at San Diego, Cal., added a new terminal building and hangar of Spanish architecture to its plant, and built 50,000 square feet of new runways after 40 acres of land were added to the existing site.



LIGHT GUN FOR AIRPORTS

New light gun projector, perfected by Westinghouse, being used from the control tower of Indianapolis Municipal Airport.

The Fresno (Cal.) Chandler Airport obtained a new \$18,000 administration building. A large terminal and administration building was erected on the Atlanta (Ga.) Candler Municipal Airport. Jacksonville (Fla.) spent \$20,500 on the erection of a new brick and steel hangar and increased the size of its municipal airport. A double Army hangar was erected on the Louisville (Ky.) municipal airport known as Bowman Field. Fifty acres were added, a 3,000 foot runway installed, and a new metal hangar erected on the Baltimore (Md.) Logan Field. Work on a new passenger terminal for the Las Vegas (Nev.) Western Air Express Airport was started. The Newark (N. J.) Municipal Airport, recognized as the world's busiest air line terminal, added a new hangar and about 45 acres of landing area to

its plant. The Camden (N. J.) Central Airport was enlarged by 28 acres and its runways widened and lengthened.

Three concrete taxi strips were added to New York City's Floyd Bennett Field. A new runway and 500 square feet of landing area were added to the Pawtucket (R. I.) What Cheer Airport. Sixty thousand dollars was spent for further improvement of the magnificent new Pittsburgh (Pa.) Allegheny County Municipal Airport, which was opened to traffic during the year. This project was described in "The Aircraft Year Book for 1932." The Cincinnati (Ohio) Lunken Municipal Airport carried out one of the



MIAMI DURING RACE TIME

Miami's Municipal Airport during the All-American Air Races staged each year in January for Florida's winter crowds.

year's most extensive runway programs, with the construction of three concrete strips 100 feet wide and two miles long. The Dallas (Tex.) Love Field, a municipal airport, built four asphalt runways, added 90 acres of land, and installed a complete new lighting system. Thirty-five acres were added and a complete lighting system installed on Rentschler Field, a United airport at East Hartford, Conn. The landing area of the Boston (Mass.) Municipal Airport was enlarged, and the Hartford (Conn.) Brainard Field almost was doubled in size. The construction of a new terminal building on the St. Louis (Mo.) Lambert-St. Louis Airport also was undertaken. The landing area of the Memphis (Tenn.) Municipal Airport was

The year's improvements throughout the country included the addition of about 2,500 acres of land to existing or new ports, the extension or installation of runways on more than 100 airports, the installation or improvement of lighting equipment at 75 fields; and the construction of approximately 100 hangars of all sizes. Several new terminal buildings were completed and landscaping projects carried out.

Lindbergh Field at San Diego, Cal., added a new terminal building and hangar of Spanish architecture to its plant, and built 50,000 square feet of new runways after 40 acres of land were added to the existing site.



LIGHT GUN FOR AIRPORTS

New light gun projector, perfected by Westinghouse, being used from the control tower of Indianapolis Municipal Airport.

The Fresno (Cal.) Chandler Airport obtained a new \$18,000 administration building. A large terminal and administration building was erected on the Atlanta (Ga.) Candler Municipal Airport. Jacksonville (Fla.) spent \$20,500 on the erection of a new brick and steel hangar and increased the size of its municipal airport. A double Army hangar was erected on the Louisville (Ky.) municipal airport known as Bowman Field. Fifty acres were added, a 3,000 foot runway installed, and a new metal hangar erected on the Baltimore (Md.) Logan Field. Work on a new passenger terminal for the Las Vegas (Nev.) Western Air Express Airport was started. The Newark (N. J.) Municipal Airport, recognized as the world's busiest air line terminal, added a new hangar and about 45 acres of landing area to

its plant. The Camden (N. J.) Central Airport was enlarged by 28 acres and its runways widened and lengthened.

Three concrete taxi strips were added to New York City's Floyd Bennett Field. A new runway and 500 square feet of landing area were added to the Pawtucket (R. I.) What Cheer Airport. Sixty thousand dollars was spent for further improvement of the magnificent new Pittsburgh (Pa.) Allegheny County Municipal Airport, which was opened to traffic during the year. This project was described in "The Aircraft Year Book for 1932." The Cincinnati (Ohio) Lunken Municipal Airport carried out one of the



MIAMI DURING RACE TIME

Miami's Municipal Airport during the All-American Air Races staged each year in January for Florida's winter crowds.

year's most extensive runway programs, with the construction of three concrete strips 100 feet wide and two miles long. The Dallas (Tex.) Love Field, a municipal airport, built four asphalt runways, added 90 acres of land, and installed a complete new lighting system. Thirty-five acres were added and a complete lighting system installed on Rentschler Field, a United airport at East Hartford, Conn. The landing area of the Boston (Mass.) Municipal Airport was enlarged, and the Hartford (Conn.) Brainard Field almost was doubled in size. The construction of a new terminal building on the St. Louis (Mo.) Lambert-St. Louis Airport also was undertaken. The landing area of the Memphis (Tenn.) Municipal Airport was

greatly improved, after bad weather and poor landing facilities forced the air lines to cancel their stops in Memphis for a short time.

The Pan American Airways continued its construction of the world's largest marine air terminal at Dinner Key, Miami, Fla. The second steel and sheet-metal hangar for giant flying boats was completed.

Facilities for lighter-than-air craft were improved with work under way on two civil airports, the Pal-Waukee Airport at Chicago and the Miami (Fla.) Municipal Dirigible Airport, to house small commercial airships. The Navy was rushing to completion its giant airship dock at Sunnyvale,



WEST POINT OF THE AIR

The Sky City created by the U. S. Army for its Air Corps Primary Flying School, now open and in full operation.

Cal., to house its second super-airship, the "U.S.S.Macon." Other airship dock projects were under consideration.

The Army Air Corps put the finishing touches on its "aviation city" at Randolph Field, Tex., the Primary Training Center, hurried completion of Barksdale Field at Shreveport, La., for an attack wing, and had projects at Hamilton Field, Marin County, Cal., and Alameda, Cal., under way. National Guard squadrons were provided with new facilities on the Boston (Mass.) Municipal Airport and the Newark (N. J.) Municipal Airport. The Department of Commerce, because of reduced appropriations, included no new construction in its program for the fiscal year 1933.

Led by Tennessee, Michigan and Idaho, several states had undertaken programs for the construction of auxiliary fields designed to provide state

airways to supplement the national system. Michigan constructed new auxiliary fields at Amasa, Harrison, Houghton Lake, Mio, Moran, Rexton, Roscommon, St. Helens, Three Lakes and Waters. Idaho conditioned a new state maintained auxiliary field at Stibnite. Tennessee continued its state program of auxiliary fields designed to eventually link Memphis, Nashville and Knoxville with an adequate airway.

Municipalities reporting the establishment of new city-owned airports to the Department of Commerce during 1932 included: Heber Springs, Paragould, and Springdale in Arkansas; Blythe, Portola, and Vallejo in



NEW ATTACK WING HOME

Barksdale Field at Shreveport, La., completed during 1932 by the U. S. Army Air Corps for the Third Attack Wing.

California; Pensacola, Sanford and Vero Beach in Florida; Bainbridge, Brunswick and Warm Springs in Georgia; Hailey and Lewiston in Idaho; Jacksonville in Illinois; Muncie and South Bend in Indiana; Des Moines and Spirit Lake in Iowa; Lawrence and Liberal in Kansas; Hammond in Louisiana; East Millinocket in Maine; Port Huron in Michigan; Bemidji in Minnesota; Joplin and Mexico in Missouri; Wolf Point in Montana; Buffalo (marine) and Geneva in New York; Burlington and Fayetteville in North Carolina; Conneaut in Ohio; Oklahoma City and Lawton in Oklahoma; Pittsburgh, Gilbertsville, Hughesville, and Johnsonburg in Pennsylvania; Galveston and Palestine in Texas; Williamsburg in Virginia; Goldendale in Washington; and La Crosse in Wisconsin.

Air line traffic on airports throughout the country showed an increase in 1932, while other forms of flying showed some decrease on many ports,

PENNSYLVANIA AIRLINES - INC.
PASSENGERS EXPRESS

DAILY SCHEDULE

WESTWARD ROUTING				EASTWARD ROUTING			
TRIP	NO. 1	NO. 2	NO. 3	TRIP	NO. 3	NO. 2	NO. 1
LV WASHINGTON	8:20A	12:30P	5:30P	10:00P	8:00A	1:45P	4:30P
AR PITTSBURGH	11:15A	2:20P	7:20P	12:25A	8:25A	2:10P	5:00P
LV PITTSBURGH	11:25A	2:30P	7:30P	11:54A	9:20A	3:05P	5:55P
LV AKRON	12:40P	3:35P	8:35P		9:30A	3:15P	6:05P
AR CLEVELAND	1:05P	4:00P	9:00P	3:05A	11:15A	5:00P	7:50P

AIRLINE CONNECTIONS

TRANSIT POINTS	AIRLINES	AIRLINE SERVICES
AKRON	1- AIRLINES	1- AMERICAN AIRWAYS
CLEVELAND	1- 4-5	2- EASTERN AIR TRANSPORT
WASHINGTON	2-3	3- DELMONTE AIRLINES
		4- TRANS-AMERICAN AIRLINES
		5- UNITED AIRLINES

REMARKS
TRIPS No. 1 and No. 2 Do not operate on Sundays or Holidays.
TRIPS No. 1 and No. 2 MAIL EXPRESS ONLY - NO STOP AT AKRON

SEE MAP BELOW FOR CITIES SERVED

AIRWAY MAP OF PASSENGER LINES

MEXICO

PITTSBURGH'S SCHEDULE BOARDS

Huge schedule boards for Pennsylvania Airlines and TWA decorate modern lobby of new Allegheny County Airport.

the Aeronautical Chamber of Commerce annual survey showed. The Newark (N. J.) Municipal Airport continued to be the world's busiest airport, with 27,000 landings and 99,600 passengers carried during the year. Other important centers were the Chicago (Ill.) Municipal Airport; Cam-

den (N. J.) Central Airport; Tulsa (Okla.) Municipal Airport; Alameda (Cal.) San Francisco Bay Airdrome; Dallas (Tex.) Love Field; Fort Worth



RYAN SCHOOL BUILDING

Ryan School of Aeronautics Administration Building on Lindbergh Field, San Diego's municipal airport, in California.

(Tex.) Meacham Field; Burbank (Cal.) United Airport; Cleveland (Ohio) Municipal Airport; and Glendale (Cal.) Grand Central Air Terminal.

The nation's leading airports and their managers will be found in an alphabetized list in Part V of this volume, "Aeronautical Directory and Trade Index."



NEW YORK AT SUNSET

Fairchild Aerial Surveys caught this unusual glimpse of New York's financial center and Upper Bay at sunset.

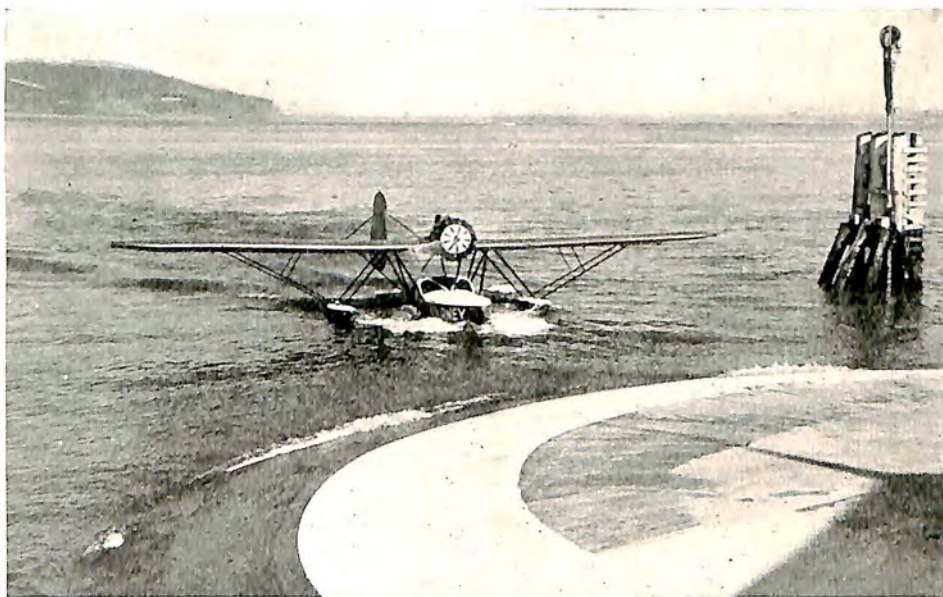

VARNEY'S TRANS-BAY SERVICE

Commutation service such as that performed by this Wasp-powered Sikorsky S-39 across San Francisco Bay offers a new field.

CHAPTER X

FLYING WITH THE AERIAL SERVICE OPERATOR

Million Passengers Carried on Short Hops and Charter Flights—Student Training Is Major Activity—Photography and Mapping Projects Completed—Annual Survey Statistics Given

EMBRACING the whole gamut of useful activities to which aircraft have been adapted, the story of the aerial service operator always is an interesting one, although his number has decreased steadily since the opening stages of the financial crisis in 1929. The annual statistical estimates of the Aeronautical Chamber of Commerce, based on detailed reports from several score typical operators, indicate that aerial service operators in the United States grossed between \$10,000,000 and \$12,000,000 during 1932. While some of the 280 operators known to be in business during the year reported increases in their total volume of business of from 10 to 18 per cent. over the previous year, most of them reported decreases averaging about 35 per cent. Gross receipts were approximately \$8,000,000 less in 1932 than in 1931.

While this meant red ink for some, many were able to adapt themselves to changing conditions and by expanding the range of their activities find sufficient work to keep them busy on missions that included everything from charter flights to crop dusting. Their planes were used for short pleasure and sightseeing trips, student instruction and solo, aerial advertising, charter trips, sales demonstrations, aerial photography, mapping, crop dusting, seeding and aerial surveys.

Reports from typical operators indicated invariably that the increase in volume of scheduled air line operation cut deeply into the field of the aerial service operator so far as the interest of the public in short pleasure and sightseeing hops was concerned. Nevertheless, the estimates indicate that 1,118,578 passengers were flown in 1932 on short hops and charter flights. While this was twice the number of passengers carried on the scheduled air lines, the duration of each hop was short and the revenue obtained comparatively small. The figure also represented a big drop from the 2,995,530 passengers carried by aerial service operators in 1929, the 2,621,769 persons carried in 1930, or the 1,875,991 patrons in 1931.

Based on typical reports, the Aeronautical Chamber of Commerce estimated that all aerial service operators in the United States piled up a total of 591,728 flying hours during 1932, about half the number of hours flown in the banner year of 1929. This flying was divided as follows: short hops, 76,640 hours; charter flights, 51,421 hours; aerial photography, 11,243 hours; mapping, 5,550 hours; crop dusting, 12,426 hours; student instruction, 183,436 hours; student solo, 176,689 hours; and unclassified activities—including sales demonstration flights, advertising, seeding, etc.—74,323 hours.

From this it was easy to see that the training of students, both dual instruction and solo, was the most important single activity of the commercial operator. Ten thousand student permits issued by the Department of Commerce and active during 1932 would not seem to indicate any waning of interest in flying for sport and business by the younger generation. •The Aeronautical Chamber of Commerce reported that 4,243 persons received pilots' licenses in 1932, of which 230 were transport licenses, 63 limited commercial licenses, and 3,950 private licenses.

The list of aviation schools holding Approved Certificates from the Department of Commerce, which accounted for a major share of the students trained during the year, will be found in Part V of this volume, "Aeronautical Directory and Trade Index." Among these schools, the Boeing School of Aeronautics, operated by United Aircraft and Transport Corporation, at Oakland, Cal.; the Penn School of Aviation, controlled by the Pittsburgh Aviation Industries Corporation, with bases in Pittsburgh and Harrisburg, Pa.; the Safair Schools; the Curtiss-Wright Flying Schools; the Ryan School of Aeronautics at San Diego, Cal.; and Parks Air College at East St. Louis, Ill., were typical examples of first class training centers in widely separated sections of the country.

The Boeing School of Aeronautics was developed by United Aircraft and Transport Corporation specifically to qualify students for responsible positions in air transport and aircraft manufacture. With a curriculum based on experience gained by United companies in flying millions of miles and manufacturing hundreds of planes and engines, the Boeing school attracted students from every state in the Union and all territories, as well as foreign countries. Many of the graduates were absorbed in various divisions of United. Attendance of 80 per cent. capacity or better was maintained during 1932. Although tuition rates were lowered during the year, the curriculum was expanded to include new and improved courses in instrument flying, communications, metal fabrication and air transport operations. A special master pilot and "refresher" course attracted considerable enrollment, as did a summer school course designed for teachers.

The Penn School of Aviation maintained its activities during 1932 on approximately the same level as 1931 at its three school bases, Pittsburgh-



TRAINING AIRPLANE MECHANICS

Students of Curtiss-Wright Aviation Schools are given thorough training in the rigging and repair of airplane structures.

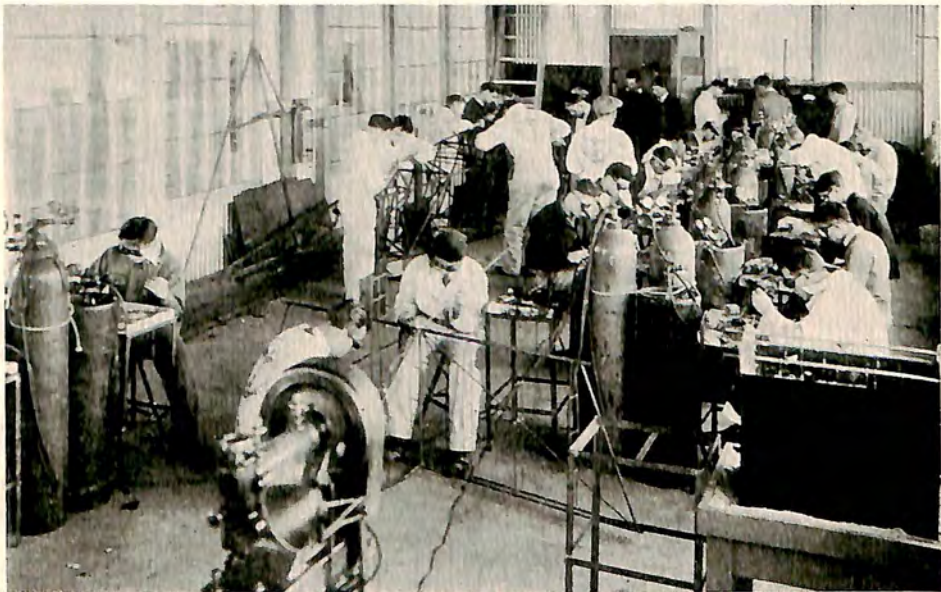

STUDENTS TAUGHT WELDING

Placing increased emphasis upon metal fabrication methods, this welding shop is an important unit in Boeing School of Aeronautics.

Butler and Bettis Airports in Pittsburgh, Pa., and the Harrisburg (Pa.) Airport. Three new courses were added to the school's curriculum during 1932: a Master Aviation Course, a six weeks practical training in business phases of the industry in addition to a complete mechanic's and pilot's course; an Instrument Flying Course, including all instruction necessary to obtain a special Department of Commerce transport instrument rating; and an Instrument Repair and Overhaul Course, including all new navigation instrument maintenance. Through the school's close affiliation with Pennsylvania Airlines, practical maintenance work was included as a feature of its courses for mechanics.

The Ryan School of Aeronautics moved its approved school into a new Spanish style administration building on the \$2,000,000 San Diego (Cal.) municipal airport known as Lindbergh Field. Parks Air College at East St. Louis, Ill., continued to operate one of the largest single-unit approved schools in the country. The Curtiss-Wright Corporation operated one of the largest chains of flying schools in the country, but turned over its school activities at Valley Stream, L. I., N. Y., late in 1932 to a new organization known as Safair.

In the field of charter flying and sightseeing hops, the activity of Newhamco Air Service at Concord, N. H., operated by Robert S. Fogg, was typical. The company concentrated its flying between June 18 and September 15 using two planes, one a cabin biplane and the other an open biplane, to take passengers on short hops from lake resorts in Maine, New Hampshire and Vermont. While a well-defined drop in passenger hopping was reported, the company increased its charter flying with special appeal to business men desiring to save time and travel more comfortably. The longest charter trip was a 3,000 mile flight to Labrador and return.

Many aerial service operators found newspapers and press associations among their best customers, calling upon them for special charter flights to important news stories in remote places, or to speed photographs or reporters from one section of the country to another.

Some aerial service operators reported a trend toward confining their activities to sales and service work, eliminating schools and other specialized work from their programs. Skyways, Inc., at Cleveland, O., was typical of this trend. Having discontinued its school in September, 1932, it concentrated on operation of an approved repair base and served as a sales organization for several airplane lines, as well as offering flying service for charter, photography, and advertising.

Farm Flying Service in Oakland, Cal., operated by Livingston G. Irving, a graduate of the University of California College of Agriculture, was representative of the aerial service operator specializing in crop dusting and seeding. This company used its planes to sow rice from March through April, dust crops with insecticide from May to October, and seed

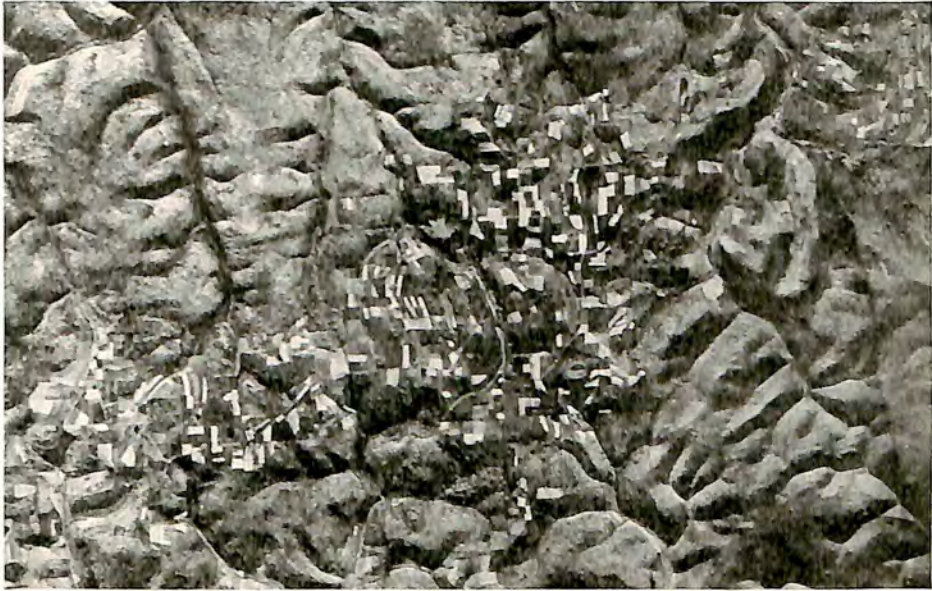

HOW AERIAL SURVEYOR WORKS

These two Curtiss-Wright Aerial Survey photographs show how the town of Germania, Pa., was first photographed from the air and the final line property map (below) was compiled from the air map.

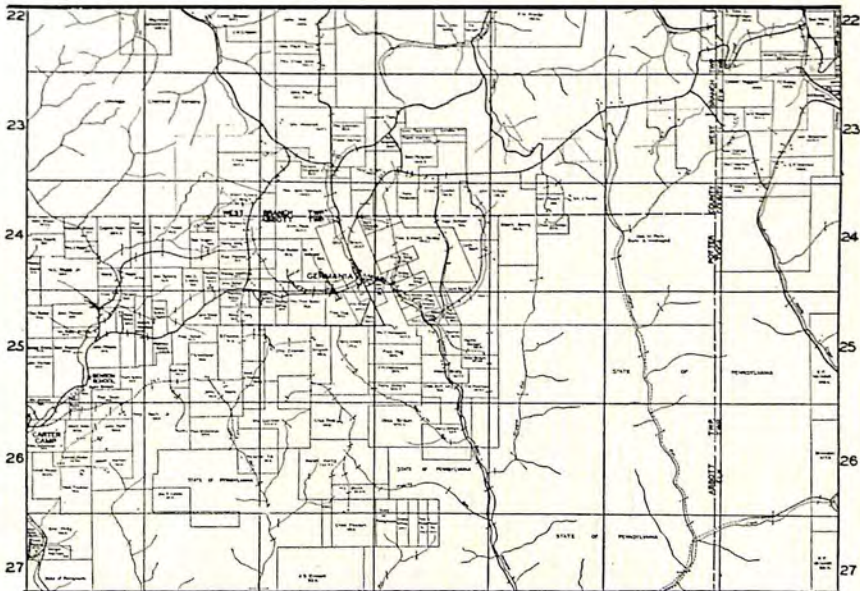

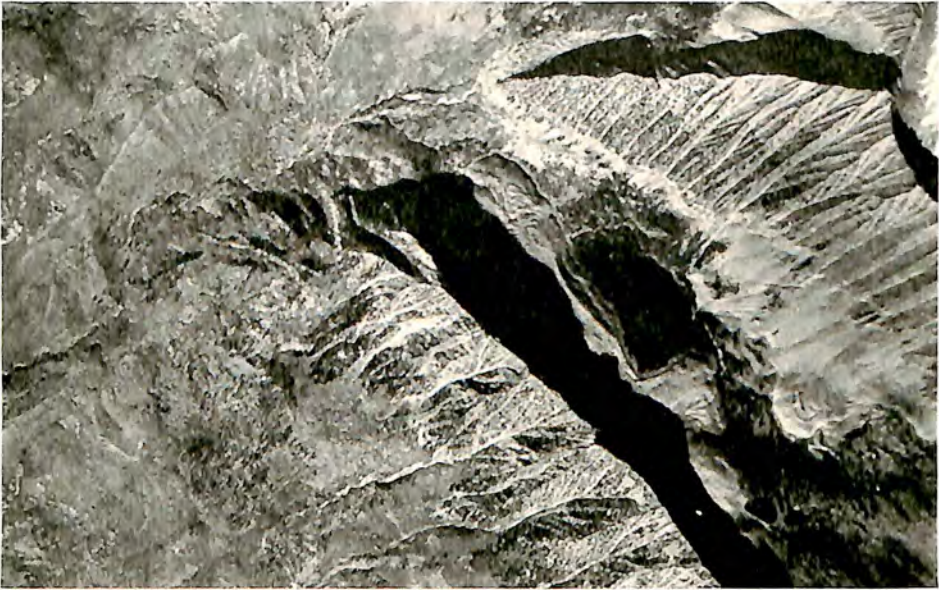

SURVEYING NATIONAL PARK

With Chair Mountain, 12,000 feet high, in the left center, this photo was taken at 22,000 feet by Curtiss-Wright in its survey of Holy Cross National Park in Western Colorado.



FOREST FIRE SURVEYS

Use of aircraft for forest fire patrols has become common, suggesting adaptability of the autogiro for such work.

range land from November to February. Flying four feet above the ground, their airplanes dropped 800,000 pounds of seed and insecticide during 1932.

The Aerial Survey Division of Curtiss-Wright Air Terminals completed several important survey and mapping projects, including 700 square miles of the Holy Cross and Gunnison National Forests in Colorado, 4,600 square miles of the new natural gas region in northern Pennsylvania, and 1,100 square miles of heavily wooded mountains in north central Pennsylvania.

Dallin Aerial Surveys of Philadelphia, Pa., completed air maps during 1932 of Trenton, Wilmington, York, Harrisburg, Reading and Wilkes-Barre as a part of its year's program in aerial photography. Fairchild Aerial Surveys, Inc., a division of Fairchild Aviation Corporation, with laboratories in New York, Dallas, Los Angeles and Mexico City, carried out an extensive program of aerial photography both for mapping and commercial advertising.

Here are a few interesting statistics on aerial service in general during 1932: 4,030 persons were employed, including 732 pilots and 1,946 mechanics and laborers; 1,979 planes were in use, including 1,915 single-engined land planes, 15 tri-motored planes, and 49 seaplanes and amphibians; 325 airports were used as bases, 65 per cent. of which were equipped for night flying; the average pilot flew 808 hours; the average sightseeing hop lasted nine minutes and cost \$1.50; and the average charter rates were: 20 to 25 cents a mile for single-engined land planes; 82 cents a mile for tri-motored land planes; 40 cents a mile for seaplanes; 75 cents a mile for single-engined amphibians; and \$1.40 per mile for twin-engined amphibians.



NEW CABIN AUTOGIRO

New Whirlwind-powered Pitcairn PA-19 over New York City near Central Park, showing distinctive new double rudder.



LANDING NEAR YOSEMITE FALLS

Demonstrating its ability to land in confined areas, a Pitcairn PCA-2 autogiro lands within Yosemite's 3,000 foot cliffs.

CHAPTER XI

AIRCROSSING IN SPORT AND BUSINESS

Sport and Business Fliers Own Half of All Commercial Aircraft—Aviation Country Clubs Round Out Fourth Year—Pleasure Aircrosses Gain in Popularity—New Soaring Records Set

WHILE the market for aircraft privately owned by individuals or corporations for sport and business flying lagged behind the outlets in the military, transport and aerial service fields during 1932, private flying still accounted for about half the commercial aircraft holding active licenses. However, the cry for economy in individual and corporate budgets during 1932 cut the estimated total distance flown by planes in this category to about 25,000,000 miles, as compared with 30,000,000 miles in 1931 and 40,000,000 miles in 1930.

Since about 60 per cent. of the privately owned planes in use were more than three years old, it appeared certain that manufacturers with designs appealing to this market could expect a large share of replacements sales in 1933, or as soon as the stringency of existing economic conditions could be relieved. With this in view, several important commercial aircraft manufacturers refined existing designs or introduced new models especially adapted to the needs of the private owner. The incorporation of such features as semi-cabin tops for open models to provide greater comfort in cool weather, storage space large enough to accommodate suitcases and sports apparel, and side-by-side seating arrangements were looked upon as steps in the right direction.

Private ownership of aircraft still continued to be confined for the most part to wealthy sportsmen or business executives who could pay for the premium of speed necessary in making business contacts or who found rest and recreation in flying. The fact that the Department of Commerce had issued nearly 19,000 pilot's licenses of which more than 10,000 were private licenses gives some indication of the possible field for expansion in the private-owner market, if the cost of ownership could be brought within the means of this class. What might be expected in the way of further expansion to reach the hundreds of thousands of air line travellers depended wholly on future engineering developments which might bring

aircraft within the reach of the unskilled operator of the type capable of owning and operating a medium-priced motor car.

Since private pilot's licenses are renewed each year, it is possible to keep a check on the number of active pilots in this class, which by law is not qualified or permitted to carry passengers for hire or reward. Disregarding the 4,193 private pilots who had not yet renewed their licenses when the study was made, the Department of Commerce learned from a check of private pilots' flying logs in 1932 that five had flown more than 5,000 hours each. This was as much flying time as many air line pilots



FOR SPORT AND BUSINESS

Continental-powered Waco four-place cabin plane combines features desired by the private owner in sport and business.

had. The study further revealed that 937 private pilots had from 201 to 5,000 hours each; that 373 had from 151 to 200 hours; 711 had from 101 to 150 hours; 1,702 had from 51 to 100 hours; and 1,840 had less than 50 hours in the air. This latter group clearly indicated the student beginners. The fact that five private pilots had flown 5,000 hours without attempting to obtain a rating in the higher license brackets—industrial, limited commercial or transport—indicated that the industry's desire to discourage non-professional pilots from obtaining professional ratings was having some effect.

The use of private aircraft for extended pleasure cruises continued to become increasingly important during 1932. Dr. R. U. Light and Dr.



IN FAST TAKE-OFF

Waco F seaplane, powered with a Warner Scarab, demonstrating its high performance in take-offs from water.



LAMBERT'S NEW SPEEDWING

"Casey" Lambert, heir to one of St. Louis' largest fortunes, in his Whirlwind-powered Curtiss-Wright Speedwing.

Norton Canfield of Boston made an air cruise from their homes in Massachusetts to Panama and return by way of Merida, Yucatan, using Dr. Light's Pitcairn for the 3,000-mile trip in a vacation spirit. Ross Hadley and John Pratt flew a Stearman over Europe, northern Africa and Asia early in the year. Lewin B. Barringer and a party of three made an air tour to the West coast and return in a Jacobs-powered Waco cabin plane, a jaunt of 5,000 miles which started from Philadelphia in the late winter. Carl Johnson and Sanborn Young of California spent six weeks in cruising 10,450 miles in a Wasp-powered Ryan through the United States and parts



AIR CRUISER AT GREENBRIER

Fred King of Wheeling, W. Va., preparing to leave Greenbrier Airport at White Sulphur Springs in his Bellanca Air Cruiser.

of Canada and Mexico. Amelia Earhart Putnam and her husband, George Palmer Putnam, made several extended air jaunts from coast to coast after her trans-Atlantic flight, including one to Los Angeles for the Olympic games.

Robert Buck of Westfield, N. J., leading exponent of flying in the nation's junior contingent, made an outstanding flight to Mexico City and on to Los Angeles. Henry King, of the cinema, used a Kinner-powered Travel Air for his vacation tour of the South. Lawrence P. Sharples combined business with pleasure in Europe by renting a plane and in two weeks flew solo a 2,100 mile itinerary which included England, France, Belgium, Holland, Germany and Denmark. Dr. John D. Brock, Kansas City ama-

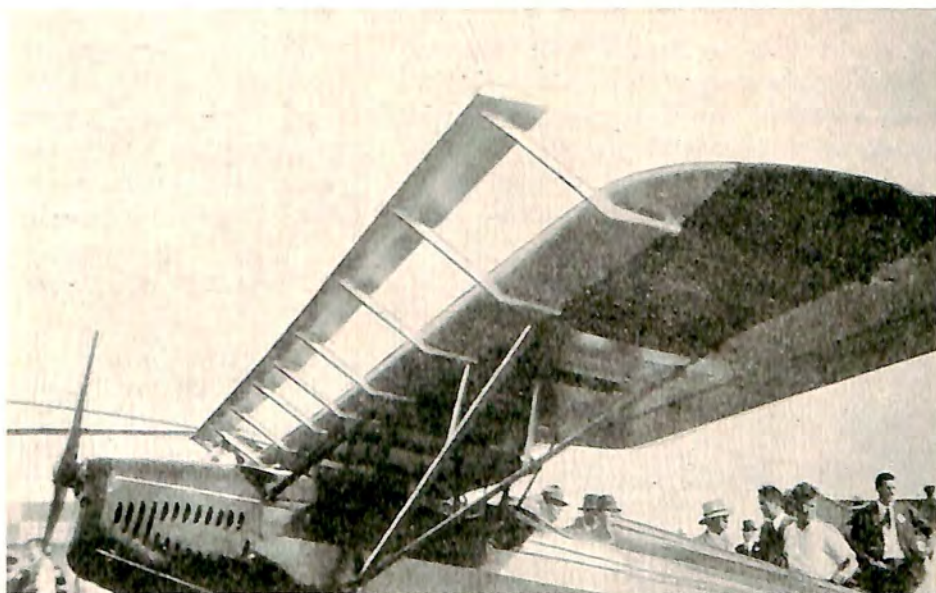

FIXED SLOTS FOR LIGHT PLANE

Fixed slot as used on Cirrus-powered Fairchild 22 in tests of the National Advisory Committee for Aeronautics.



LIGHT PLANE FOR PRIVATE FLIER

The Fairchild 22, powered with an American Cirrus engine, was designed for the private light plane owner.

teur pilot, continued to maintain his unique record of making at least one flight every day regardless of weather. He started his daily flight log November 15, 1929.

Newspapers, insurance companies, oil drillers, power interests, advertising agencies, department stores, publishing houses, automobile, accessory and tire manufacturers, as well as dozens of other classes of industrial concerns, continued their operation of corporately owned planes for a wide range of purposes.

The Champion Spark Plug Company, for instance, sent its pilot, Capt.

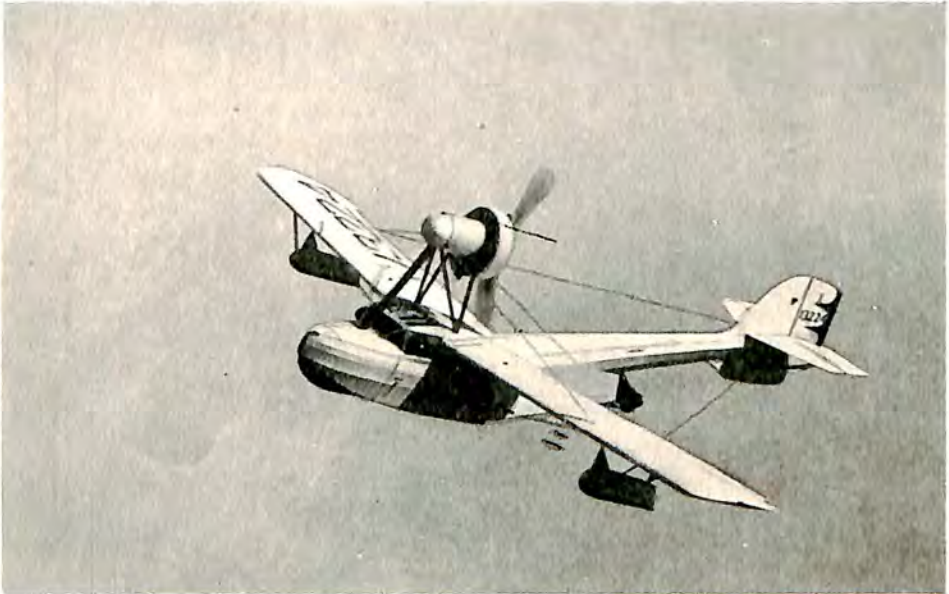

NEW CABIN AMPHIBION

Whirlwind-powered Privateer P-3, built by Amphibions, Inc., is a three-place cabin amphibion with pusher engine.

Lewis A. Yancey of trans-Atlantic fame, all over the United States, across the straits to Havana, Cuba, then over the Caribbean to Merida, Yucatan, up to Mexico City, and back to the United States by way of Brownsville, Tex., in a Pitcairn (Wright Whirlwind) autogiro. The Standard Oil Company of New York sent its Bellanca, piloted by Capt. Julian S. Dexter, through most of the company's New York state and New England territory, participating in sales conference programs, transportation of executives, local sales promotion, and advertising. John Udd, president of the Ford hotels, bought a Whirlwind-powered Curtiss-Wright Commuter for travelling between the company's units in Buffalo, Toronto, Montreal,

Utica, Schenectady and Syracuse. Similarly, several hundred industrial concerns made use of the air fleets.

William T. Campbell, pilot for the Coca-Cola Company, flew Dr. Felix De Roy of Belgium above the cloud-enshrouded countryside of New England in an autogiro to make a scientific study of the total eclipse of the sun, which was not visible from the ground. Al D. Myers, for 32 years a prospector in the Far West with a mule as his chief mode of transportation, enlarged the scope of his work through the extensive use of a new Kellett Autogiro purchased during the year.



SIDE-BY-SIDE LIGHT PLANE

Its two passengers seated side-by-side, the new Aeronca light airplane is powered with a new design Aeronca engine.

Several companies carried on sales goodwill tours with marked results. Capt. Earle S. Eckel, pilot for the Tide Water Oil Corporation, made 1,750 flights with 1,550 passengers using the company's autogiro. Don Walker, pilot for the Sealed Power Corporation, flew his company's autogiro on one of the most extensive campaigns of the year, flying 60,000 miles to visit 225 cities in 22 states and Mexico. He made 2,100 landings and carried 3,066 passengers.

Juan de la Cierva, inventor of the autogiro, was met by a Pitcairn model directly at the pier when he arrived from Europe early in the year, and was whisked away to the Willow Grove plant of the American company for

a conference. Mr. Cierva was flown to Washington a few days later to visit the White House upon invitation from President Hoover.

Because non-professional flying lent itself easily to becoming a part of social activities promoted in a club atmosphere, the Aviation Country Club plan rounded out its fourth year of operation with the opening of three new units during 1932. The Aviation Country Club of Philadelphia, housed in a colonial structure on its own flying field at Blue Bell, Pa., was opened in May, 1932; and the Aviation Country Club of Westchester, acquiring the field and facilities formerly operated by Westchester Airports Corporation at Armonk, N. Y., started its activities in September. Another



NEW TRAVEL AIR SPORT

The Travel Air Sport, produced by Curtiss-Wright, is powered with a Wright Whirlwind 165 horsepower engine.

unit, established late in 1931 in a picturesque setting at Westport, N. Y., on Lake Champlain, started actual operations in June, 1932. Known as the Aviation Country Club of Lake Champlain, it combined the features of an elaborate country club with land and seaplane facilities. An 18-hole golf course, a modern yacht club, three tennis courts, and facilities for hunting, ice-boating and riding were available.

The Aviation Country Club of Long Island at Hicksville, L. I., N. Y., continued to be the largest and most active unit of the group. Ten members purchased new planes during the year: Carlton Putnam, a Wasp-powered Bellanca; R. L. Brooks, a Lambert-powered Monocoupe; Kenyon

Boocock, Wasp-powered Stearman Beta; Charles Carey Rumsey, jr., a Lambert-powered Monocoupe; Luis de Florez, a Cirrus-powered Fairchild; Aline Rhonie, a Lambert-powered Monocoupe; Jack Rutherford, a Continental-powered Waco; Mrs. Edmund Guggenheim, a Wasp-powered Lockheed Air Express; Willis George, a Continental-powered Waco; and George W. Hard, a Whirlwind-powered Travel Air. Planes owned by the club for rental to members were flown 468 hours during 1932. Three members of the Westchester Aviation Country Club, Edward Noble, J. J. White and Robert Noble, purchased Kinner-powered Pitcairn autogiros during 1932.



HIGH ABOVE LOS ANGELES

New Kellett K-3 side-by-side cabin autogiro, powered with a Continental engine, is seen flying above the City of Angels.

The United States Amateur Air Pilots Association, formed during 1931 to promote non-professional flying, staged two aircruises, and several events in the National Air Races for 1932. Members of the association owned and operated 168 airplanes during the year, ranging from Aeroncas to Sikorskys. Charles M. Taylor of Little Rock, Ark., won the annual amateur cruise to the National Air Races for the Charles Lanier Lawrance Trophy. Twenty-eight members participated in the three-day cruise to Miami, Fla., for the All-American Air Races early in 1932, and plans for another cruise to Miami were under way late in the year. Henry L. Doherty planned to offer a trophy in conjunction with the 1933 cruise. The

association also sponsored for the first time an inter-club relay for amateurs at the National Air Races, won in 1932 by a team from the Montreal Light Plane Club.

Gliding and soaring in the United States, while limited to a small number of interested participants, made progress during 1932 if records are to be taken as a criterion. The Soaring Society of America, Inc., formed to sponsor soaring as a sport, staged the third annual national soaring meet at Elmira, N. Y., July 11 to 24, 1932, which attracted 45 contestants, six



FROM HOME TO POLO FIELD

Capt. Pierson and Samuel Metzger land at the Menlo Circus Club Polo Field in California for a chukker or two.

sailplanes and 12 utilities. From the ridges surrounding Elmira, 153 soaring flights were made and 29 new soaring licenses earned.

Walter Snell of Providence, R. I., made what was believed to be a world record for speed in a glider when he covered the measured course at an average speed of 38.7 miles an hour. The best marks made by pilots in the sailplane division were: distance across country, J. K. O'Meara of New York, 66.6 miles, landing in Tunkhannock, Pa.; altitude, Martin Schempp of Pittsburgh, Pa., 5,370 feet; duration, J. K. O'Meara, 8 hours and 18 minutes. Schempp almost equalled O'Meara's record for distance by soaring 63.7 miles to Gelatt, Pa. In the utilities division the best performances were: duration, Stanley Smith of Ann Arbor, Mich., 8 hours and

8 minutes; distance, Robert Eaton of Norwich, N. Y., 29.5 miles; and altitude, Robert Eaton, 3,415 feet.

For the first time, two-place utility gliders made their appearance, one designed and flown by Dr. Frank Gross of Akron, O., and the other an Alfaro design flown by Lieut. Comdr. Ralph S. Barnaby of the U. S. Navy. The first machine was flown 7 hours and 31 minutes to win the duration contest in the two-place class, and Lieut. Comdr. Barnaby won the altitude competition with a mark of 2,310 feet.



BUILDING AN AIRWAY

This donkey will attest the difficulty of building airways in Arizona's mountains as he carries a beacon cover glass.

CHAPTER XII

AERONAUTIC PROMOTION AND REGULATION

Department of Commerce Improves Aids to Air Navigation—Enforces
New Requirement on Instrument Flying—Maintains Close Liaison
With Industry—N.A.C.A., Other Bureaus, Active

PURSUING its policy of allowing the aviation industry a wide measure of self-regulation, the federal government carried on an important program of promotion and regulation of aeronautics through the Department of Commerce and continued research in this new field through the National Advisory Committee for Aeronautics and the Bureau of Standards.

A constructive liaison was fostered between the Aeronautical Chamber of Commerce of America, the industry's trade association, and the Aeronautics Branch of the Department of Commerce, which, in addition to its regular duties of promoting and regulating air commerce and constructing and maintaining airways, was engaged in many projects designed to add to its service to the aviation industry and to protect and aid the flying public. Similar cooperation was afforded the industry through the Aeronautics Trade Division of the Bureau of Foreign and Domestic Commerce, which directed a program for the expansion of American aircraft markets at home and abroad. The Chamber cooperated with this Division in the publication regularly of the *Export Trade News*, containing trade information for the aeronautic exporter, and obtained the assistance of the Division's representatives abroad in collecting information for this volume on aviation development throughout the world.

The projects of the Aeronautics Branch during 1932 involved all three of the Branch's main activities: the Air Regulation Service, the Airways Division and the Aeronautic Development Service, all under the direction of the Assistant Secretary of Commerce for Aeronautics in pursuance of the Air Commerce Act of 1926. This Act was passed as a result of the aviation industry's request for regulation, the first time in history that an industry made such a request.

The most important new policy adopted by the Aeronautics Branch with respect to regulation dealt with scheduled air line operation. Under

an amendment to the Air Commerce Regulations Governing Scheduled Operation of Interstate Air Passenger Services, all pilots engaged in such services were required to hold scheduled air transport ratings, effective January 1, 1933. To qualify for the rating, pilots had to have at least 1,200 hours of certified solo flying time in the previous eight years, including 500 hours of cross country flying and 75 or more hours of night flying. The pilot was required to pass a written examination on the use of radio and other aids to air navigation, and tests in meteorology on weather analysis and forecasting. His ability to fly by instruments was tested in a flight



GOVERNMENT CHECKS SAFETY

Testing the control system with loads on the ailerons is but one of the Department of Commerce's many airworthiness tests.

during which he operated the plane while under a hooded cockpit with a Department of Commerce inspector as check pilot.

Indirectly this rating carried with it the requirement that all aircraft employed in scheduled air passenger service be equipped with types of instruments necessary for instrument flying. The Department of Commerce, through its new policy, did not intend to authorize intentional instrument flying with passengers, but required the qualification to assure fitness of pilots and aircraft for emergency use should instrument flying become necessary.

The inspection work of the Branch was improved during 1932 by the

division of the United States into three main inspection divisions: Eastern, Central and Western, with a chief inspector in charge of each division.

The usual annual conference of officials of the Aeronautics Branch with the entire aircraft manufacturing industry was not held during 1932 as no major changes in the regulations were proposed, but a Committee of Engineers from the Aeronautical Chamber of Commerce held two meetings with Department representatives. Points in question were disposed of, and several minor changes incorporated in the new edition of Aeronautics Bulletin No. 7-A, Airworthiness Requirements of Air Commerce



INSTRUMENT FLYING REQUIRED

With January 1, 1933, as the deadline, many air line pilots busied themselves in hooded cockpits like this to pass new tests.

Regulations for Aircraft. However, the Engine Manufacturers' Section held the first conference that it has had with the Aeronautics Branch, with the result that substantial revisions in the engine regulations were made. Requirements governing the airworthiness of aircraft components and accessories were to become effective early in 1933 as the result of agreements between the Aeronautics Branch and the Accessory and Material Section of the Chamber on the text of Aeronautics Bulletin No. 7-F.

Several hundred persons took advantage during the year of the liberalized eyesight requirements promulgated by the Department of Commerce. The requirements permit and at the same time require students and private

pilots with slightly defective vision to wear correcting lenses while operating aircraft.

On January 1, 1933, nearly 19,000 pilots held active licenses issued by the Department of Commerce, and there were also about 10,000 student pilots who held Department student permits. Nearly 8,000 aircraft had complied with the Department of Commerce regulations and had been issued licenses. More than 8,000 held mechanics' active licenses from the Department.

There were 19,500 miles of federally lighted and radio equipped airways

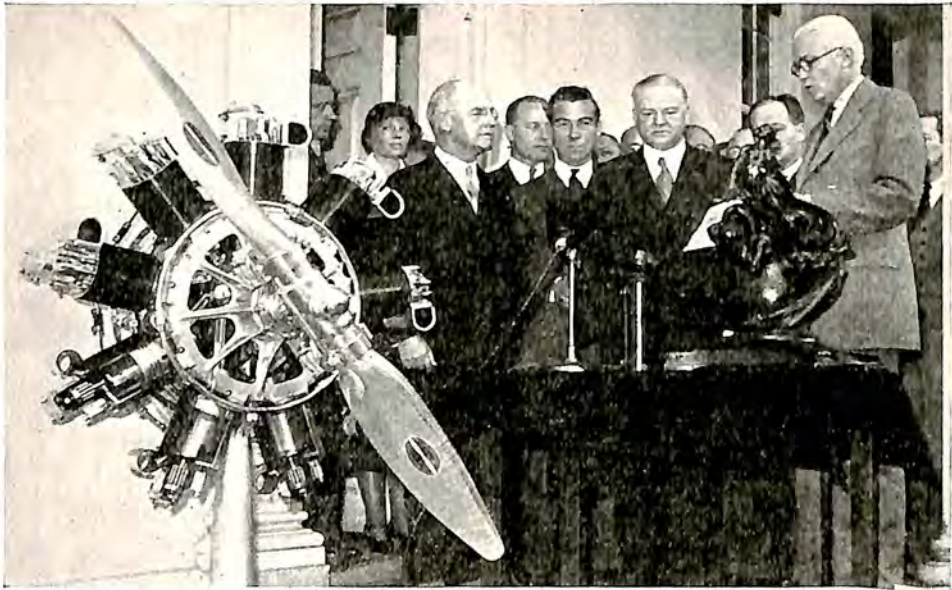

PACKARD RECEIVES COLLIER TROPHY

President Hoover presents the Collier Trophy to the Packard Motor Car Company for its Diesel aircraft engine work.

in operation at the opening of 1933, which included three transcontinental routes in addition to numerous other connecting airways. Of these, 2,000 miles were constructed in the program authorized by Congress for the fiscal year ending June 30, 1932. In accordance with the government's program of economy, no new construction was undertaken for the fiscal year 1933. Experiments conducted during the year proved the practicability of the transmission of weather maps by means of teletypewriter circuits. An experimental circuit over which maps were transmitted at intervals of three hours was successfully maintained for three months. The purchase by the Aeronautics Branch during the year of teletypewriter equipment on airways circuits, including page machines and automatic transmitting equipment,

was brought about as an economy measure to reduce the overall cost of the teletypewriter system. Further tests also were conducted on a radio-operated teletypewriter service, with marked success.

A new type radio range beacon antenna was developed by the Aeronautics Branch for the elimination of night course variations experienced in mountainous terrain. It consisted of four 125-foot insulated towers connected by special transmission lines. Contracts were let for the installation of the new type antenna at 50 radio range beacon stations.

In the field of airway lighting, excellent results were obtained in tests



WINGS FOR COAST GUARD

Named the "Altair," this new twin-engined flying boat is one of several built by General Aviation for the Coast Guard.

of a photoelectric cell to be used as a prime element in automatic switching on and off of airway beacons. While it had not yet developed versatility equal to the astronomic time switch in automatically controlling all types of airway beacons, it had the advantage of being able to switch on the beacon current whenever daylight falls below a certain intensity.

With the close of 1932, the airways were lighted by nearly 1,700 rotating beacons, spaced at intervals of 10 to 15 miles along each lighted airway. These lights were equipped with course lights which by color and code characteristics, indicate the presence or absence of landing facilities and give the number of each beacon along the airway.

Department of Commerce intermediate fields, nearly 370 in number

at the close of the year, were so located with relation to municipal, commercial and private airports that landing facilities were available at intervals of 40 to 50 miles along the airways. Airways radio communication stations, the number of which was increased to 70 during the year, furnished complete weather information by radiotelephone in frequent broadcasts to pilots. The number of radio range beacons, which project radio beams for the guidance of aircraft at all times, was increased to 94 during the year. A new type marker beacon was developed, 20 of which were being installed, to facilitate direction and communication in bad weather.

In the field of aeronautic development, a number of research projects were carried out in addition to the publication and dissemination of information, including airway bulletins, statistics, promotional matter and maps. In conjunction with the Bureau of Standards, a study of reduction of airplane noises by means of mufflers was conducted, complementary to previous studies on the insulation of cabins against noise. Experimental work on crash-resistant fuel tanks was completed during 1932, with data to be made public in 1933. Improvement on various features of the radio systems also was undertaken. The development and service testing of an air traffic control projector, capable of sending code flashes in red or green up to six or eight miles, was completed.

The encouragement of airport development and the rating of airports was an active part of the work of the Aeronautics Branch during 1932. Nearly 700 communities desiring assistance in the selection of airport sites and information of airport requirements utilized the field advisory service of the Aeronautics Branch.

The National Advisory Committee for Aeronautics, created by Congress in 1915 and equipped with one of the best research laboratories in the world, continued to work with the several departments of the federal government and with the commercial industry on fundamental problems of flight. The results of the Committee's research were made available to engineers in the industry through technical bulletins issued at frequent intervals. The Committee held its Seventh Annual Aircraft Engineering Research Conference at Langley Field, Va., to which members of the Aircraft and Engine Manufacturers' Sections of the Aeronautical Chamber of Commerce were invited.

Several governmental boards, formed to coordinate the work of various departments and bureaus of the federal government, continued their activity during the year. The Aeronautical Patents and Design Board, created to inquire into the value and possible use of aeronautical inventions by the government, considered several score designs passed on to it by the National Advisory Committee for Aeronautics. The Helium Board acted as a coordinating agency and advisory board of the Army, Navy and Bureau of Mines departments interested in the non-inflammable lifting gas used for

airships. Duplication of effort in the Army Air Corps and Navy Bureau of Aeronautics came under the scrutiny of the Aeronautical Board. The Board of Surveys and Maps similarly brought together various departments in the government interested in the development of maps. The boards were of real value in cutting expenses of the federal government through elimination of waste effort.

The United States Coast Guard, rendering an important service to peacetime shipping, expanded its aviation division with the addition of five new twin-engined FLB flying boats built by the General Aviation Manufacturing Company and described in a later chapter on "Trends in American Aircraft Design." The new boats started useful service soon after they were commissioned by answering calls to take stricken seamen from ships at sea and rush them to hospitals on shore for medical attention. Aviation was proving itself an extremely useful adjunct to the Coast Guard service.



DES MOINES' FLYING REPORTERS

Returning from another big news story, the Pitcairn autogiro "Good News III" of the Register and Tribune lands tail first.

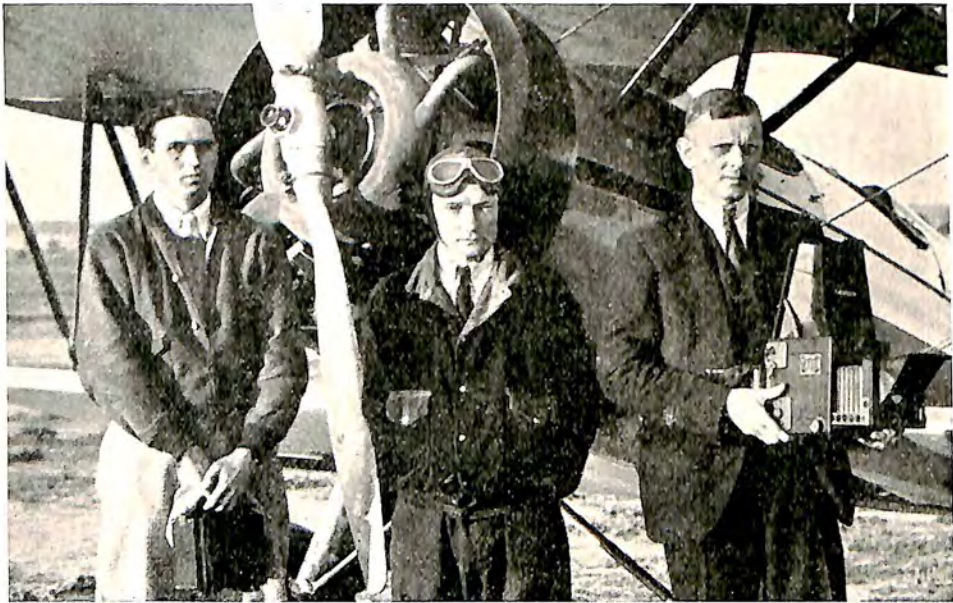

DAYTON HERALD'S FLYING STAFF

Fred J. Van Pelt, Robert Thompson, and Morris Fawcett of the Dayton Herald ready to fly to the "story of the day."

CHAPTER XIII

AVIATION AND THE PRESS

Air Transport Aids Newspapers In Covering Year's Biggest Stories—Flying Reporters and Cameramen Used For Political Conventions, Hurricanes, Wars, Riots, Etc.—Aviation Editors Busy on 117 Major Dailies.

THE growth and prosperity of American Journalism since the establishment of the first newspaper in the New World has been linked inextricably with the progress of communication facilities. It is logical, therefore, to expect to find aviation—the newest means of communication and transportation—playing a vital part in further speeding up the tempo of activity in the news and circulation departments of principal newspapers throughout the country during 1932.

Almost all major news stories of the year—wars, hurricanes, tornadoes, political conventions, sporting events, fires, riots, and other events which furnished material for banner lines—were covered through the use of airplanes, either privately owned by enterprising newspapers or chartered for the occasion by press associations or important metropolitan dailies. Likewise, the circulation departments of many papers used planes to speed “extras” and special editions to other sections of the country in their never-ending race to score a “beat” over contemporaries.

Aviation itself furnished the subject matter for scores of good news stories during the year, and because of its popular appeal and newness many newspapers assigned specially retained reporters or aviation editors to cover stories in the aeronautical field. The need for well-trained newspapermen to cover aviation stories in an intelligent and accurate manner resulted in the designation of qualified men with the title of aviation editor on, at least, 117 daily newspapers in the United States. The list of newspapers having such special editors assigned to aviation will be found in Part V of this volume, “Aeronautical Directory.” The names of the aviation editors together with other pertinent information on the relation of aviation to the press was collected through questionnaires sent out to all newspapers in the United States having daily circulations in excess of eight thousand. The questionnaires furnished the machinery for the Second Annual Avia-

tion-Press Survey made by the Aeronautical Chamber of Commerce of America especially for "The Aircraft Year Book." It should be interesting to compare the 1932 data with that obtained in 1931, and published in "The Aircraft Year Book for 1932."

Nineteen newspapers carried a daily aviation column during 1932 entirely devoted to news in the aeronautical field. Forty-six other dailies published special pages or columns on aviation on a weekly schedule, most papers running them as special features on either Saturday or Sunday. Three papers published their aviation features semi-weekly, and three others developed special feature columns for use at frequent intervals without any definite schedule. These special feature columns or pages were in addition to the day-to-day "spot" news stories on aviation, carried on the basis of news developments and their current merit.

A detailed study of representative newspapers throughout the United States during the year revealed that newspapers generally were paying even stricter attention than in past years to the problem of covering aviation news—and especially aircraft accident news—accurately and fairly. Aviation brought with it a whole new vocabulary for the world to master, and because of its very newness and somewhat spectacular character presented serious problems for the press to overcome in its desire to present all news accurately and fairly. To aid in obtaining a clearer understanding of the problems of the aviation industry as they are related to the press, the Aeronautical Chamber of Commerce of America completed early in 1932 an effort which it had started in 1931 to visit personally most of the editors and publishers of key newspapers in every one of the 48 states and obtain a full discussion of the problems involved. The result was the setting up of a closer liaison between the newspapers and the aviation industry and a better understanding of each others' problems. Suggestions made by newspaper editors and publishers were passed along to corporations in the aeronautical industry so that certain practices might be changed to obtain fuller cooperation between the two industries.

Thirty-one newspapers chartered airplanes during 1932 to aid in covering major news stories of the day, most of them outside the aviation field itself. The use of air transport by political candidates, including the successful candidate for the Presidency, furnished one of the chief stimuli for the chartering of special planes so that political reporters might follow their news sources at speeds as fast as the candidates themselves were employing.

Forty-six newspapers utilized the extensive services of the regular air transport lines to dispatch reporters on missions which ran the gamut of the year's biggest stories. Eleven newspapers chartered planes to rush news pictures from distant points to their plants to make early editions, and the press associations also made important contributions in this field.

Eleven planes were chartered to cover emergency stories, such as storms, fires, and riots.

The Associated Press sent its Havana correspondent in a chartered plane to obtain the first eye-witness account of the devastation and loss of life caused by the Cuban hurricane during 1932. It rushed its Miami correspondent via Pan American Airways' plane to Havana to assist in sending out news and pictures of the hurricane's destruction to all parts of the world. Russell Boardman rushed the first pictures taken by The Associated Press of the Republican National Convention in Chicago to New York,

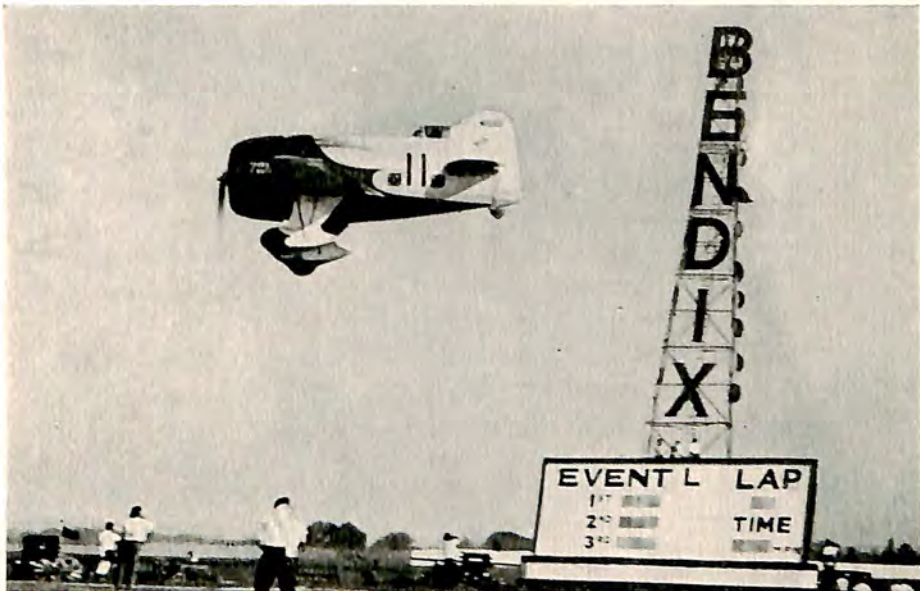

SETTING NEW WORLD RECORD

Maj. James H. Doolittle in his Wasp-powered Gee Bee racer setting a new world speed record for land planes at Cleveland.

making the trip in four hours and six minutes. Seaplanes and land planes were used to relay the first pictures of the Sino-Japanese warfare to New York from the west coast via Seattle. Special planes were chartered by The Associated Press on this occasion to put the pictures into New York even faster than the regular air mail schedules. Through the use of United Air Lines, The Associated Press often provided pictures for Sunday editions of Chicago newspapers, made from original prints, of events developing in New York late Saturday afternoon.

The International News Service, likewise, made considerable use of air transport in speeding up the tempo of its service. Its Miami correspondent was dispatched by air to survey the extent of the hurricane devastation in

Great Abaco Island, off the Florida coast, September 15. Its Shanghai man made a flight over the battle area during the Sino-Japanese conflict, and wired back a brilliant eye-witness account for use in American newspapers. In fact, the major press associations utilized chartered planes or the services of the regular air lines whenever big stories developed and emergencies prompted quick action.

The Birmingham (Ala.) News and Age Herald was the first newspaper to reach the scene of the tornado which claimed 300 lives at Northport, Ala., across the Warrior River from Tuscaloosa. Lieut. Walter Wise of the Alabama National Guard flew the News and Age Herald aviation editor, Ralph Hurst, to Tuscaloosa to obtain the first pictures and news account of the severe storm, after other reporters dispatched by automobile were cut off by the destruction of bridges and a section of the road. The photographs were then flown by American Airways from Birmingham to Atlanta to be telephotoed to other newspapers throughout the United States. The Arkansas (Little Rock) Gazette obtained some excellent aerial photographs of the low stage of the Arkansas River, taken by its flying photographer, Joe B. Wirges. The pictures presented a far different story from that of 1927 when the Gazette used planes to report the river's devastation from floods.

The Evening Star (Washington, D. C.) chartered a plane equipped with colored neon lights and Very pistol flares to announce the trend of the national election which swept Franklin D. Roosevelt into the Presidency. The Star also used planes to obtain pictures and descriptions of the Bonus army camps, the "hunger marchers," and the progress of the Federal building program. The Jacksonville (Fla.) Journal sent its aviation editor, May McCormick, in a plane chartered by officers of Glynn County, Ga., to search for two negroes accused of shooting an officer, and believed to be hiding in a thickly wooded section. An hour's flight over the woods and swamps resulted in the spotting of one of the fugitives who was run out of the swamp into the arms of officers. Later in the day, the Jacksonville paper printed pictures and news stories of the successful search, and the lynching at the hands of a mob, which followed the negro's discovery.

The Georgian-American (Atlanta, Ga.) published pictures in its early Saturday night edition of outstanding plays in the Auburn-South Carolina football game, which had been staged in Birmingham a few hours before. General Air Express and the facilities of American Airways were used to transport pictures of the game, which had an important bearing on the Southern Conference football title.

Chicago's newspapers pooled their efforts by sending six reporters and a representative of the State's Attorney's office to Canada when Martin Insull, Chicago utility magnate wanted for questioning in connection with the crash of his financial enterprises, fled from the United States. The

Chicago Daily News sent its aviation editor, Charles Schwarz, to the Olympic games in Los Angeles by air, and brought back several Olympic stars by plane for a benefit meet sponsored by the paper in Chicago. The Chicago Tribune chartered planes to fly pictures of the Kentucky Derby, Indianapolis Speedway Classic, coal mine riots in Southern Illinois, major prize fights and other news stories of the year.

The Fort Wayne (Ind.) Journal Gazette used the facilities of Transcontinental and Western Air and Transamerican Airlines to dispatch its reporters to the scenes of important stories several times during 1932. The



CROWDS AT NATIONAL AIR RACES

One of the biggest crowds is seen in the stands on the Cleveland Airport during the ten day National Air Races program.

Fort Wayne (Ind.) News-Sentinel used its own plane, a Whirlwind-powered Ryan cabin monoplane, on major stories, although the ship was used chiefly to build good-will through flights to nearby towns in its trade territory. The Indianapolis (Ind.) Star sent its sports editor, W. Blaine Patton, by air to Miami to cover the All-American Air Races there in January, while its aviation editor, Walter F. Morse, flew to the National Aircraft Show in Detroit; and a feature writer, Mary E. Bostwick, travelled with the 1932 Indiana Air Tour to write a day-to-day account of the event. Plans of a leading competitor to send its sports editor by high-powered motor car into the state's 16 regional basketball championship centers to get advance "dope" spurred the Indianapolis Times to send its sports writer,

Dick Miller, by plane to obtain all of the information in but a fraction of the time planned by his contemporary. Success of the venture resulted in plans for its repetition in 1933.

The Tribune (Sioux City, Ia.) reported airplanes to be invaluable in sending its aviation editor, Henry B. Cooper, to cover flood, tornado and grasshopper stricken areas. The Louisville (Ky.) Times and The Courier-Journal sent its flying photographer, G. G. McNeill, in a chartered plane to Crossville, Tenn., when a baby resembling the kidnapped son of Col. Charles A. Lindbergh was reported found there. Within a few hours, pictures of the crowds around the jail at Crossville and of the little mountain town itself were back in Louisville for early editions of the Courier-Journal. In August, its staff photographer took pictures from the air of Army maneuvers at Fort Knox.

Representatives of the Boston (Mass.) Evening Transcript flew more than 100 hours during 1932 on news stories, climaxing their activities with the flight of George Mason on August 31 to obtain an unobstructed view of the total eclipse of the sun in New England from 16,200 feet, when the view of observers on the ground was cut off by heavy clouds. The Transcript's aviation editor, Franklin Jordan, made numerous trips on other stories during the year. The Detroit (Mich.) News, likewise, sent its aviation editor, James V. Piersol, to New England to obtain a description and photographs of the solar phenomenon, using the Wasp-powered Lockheed Vega monoplane owned by the paper. The Detroit (Mich.) Free Press obtained special permission from the Department of Commerce to permit the specially chartered plane carrying two of its cameramen to fly low over the Detroit River during the Harmsworth Trophy Speed Boat Race, and obtained some excellent shots. Since Detroit was without direct telephoto service, the Free Press used the facilities of Transamerican Airlines extensively to rush stories of the Lindbergh baby kidnapping and the two political conventions to Detroit.

The Kansas City (Mo.) Star chartered planes to fly newspapers to important regional football games, so that editions containing accounts of the games might be sold at the stadium gates as the spectators left. The Star also sent its motion picture critic, John C. Moffitt, by air to California to obtain a series of interviews with motion picture stars in Hollywood. Moffitt wrote the script for the motion picture "Air Mail," released during the year.

The Great Falls (Mont.) Tribune, like other papers in the Rocky mountain states which previously waited days for important news pictures, enjoyed unusually good service through the combined use of telephoto and air mail to speed pictures of the political conventions and the World Series to its news rooms. The photograph of Senator Thomas J. Walsh of Montana taking over his duties as permanent chairman of the Democratic

National Convention in Chicago was telephotoed from Chicago to San Francisco and air mailed to Great Falls, being received in less than 20 hours after the film was developed. The facilities of United Air Lines and National Parks Airways were used to speed the pictures from San Francisco.

The Jersey (Jersey City, N. J.) Journal used planes to transport a special edition containing the speech of Franklin D. Roosevelt at Sea Girt, N. J., in time to sell to the crowds assembled there by the time the Presidential candidate had finished speaking. The Brooklyn (N. Y.) Times Union established what it believed to be a record in 1932 by the publication

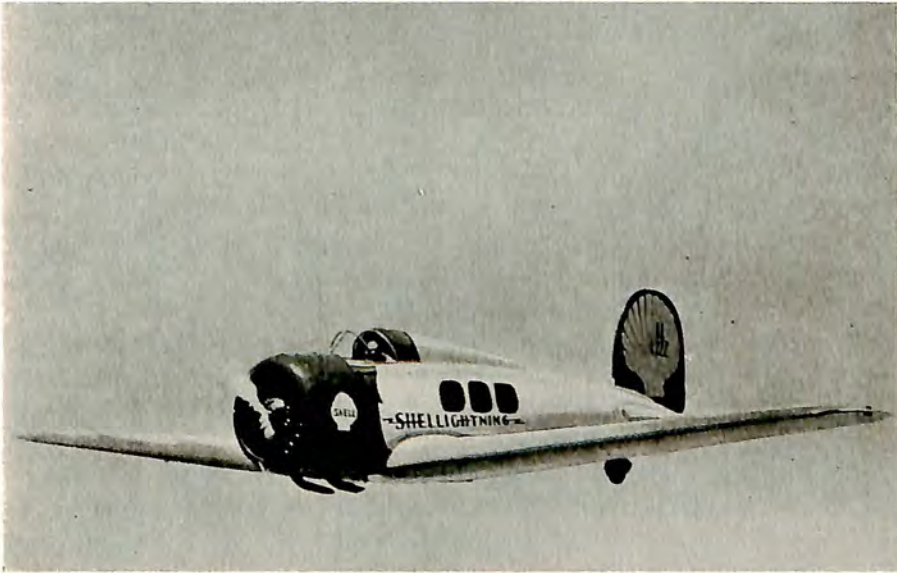

LIKE GREASED LIGHTNING

Maj. James H. Doolittle tucks up the wheels of his Cyclone-powered Lockheed Orion, world's fastest transport.

of 476 columns, or about 10,000 inches of special aviation news features, exclusive of "spot" news. One of its reporters, Gerald D. McClean, added to his experience of having flown 15,000 miles as a passenger, by learning to fly during 1932. After receiving his pilot's license, he wrote an illustrated series of stories called "The Skylarking Reporter." He viewed the eclipse of the sun from 18,000 feet, and later "scooped" contemporaries by obtaining an eye-witness account of a train wreck near Montauk Point, L. I.

The Columbus (Ohio) Citizen, a Scripps-Howard paper, sent photographs of the state's new \$5,000,000 office building after it had been wrecked by an explosion in April, to three other Scripps-Howard papers in Ohio, The Cincinnati Post, The Akron Times-Press, and Cleveland

Press, using the facilities of American Airways. Ohio State University's football games, likewise, served as subjects for news photos which required speedy dispatch.

The Daily Oklahoman (Oklahoma City, Okla.) scored a "beat" in November by publishing an eight-column picture of the Oklahoma-Iowa State football game in its early Sunday editions, which had been taken by Ennis Helm, staff photographer, after a 1,000 mile flight across three states and into a fourth to obtain the "scoop." The Oklahoma City (Okla.) Times gave its readers the first picture of the serious flood which was threatening the city in June, by publishing a full-page aerial view of the flood area in its pink edition.

The Oregonian (Portland, Ore.) sponsored a unique one-day flying tour of the national parks, national monuments and points of scenic interest in the Northwest. Shell Oil's Lockheed Vega monoplane, piloted by William G. Fletcher, was used and Palmer Hoyt, executive news editor of The Oregonian, wrote a brilliant story of the 2,375 mile flight, which was illustrated with aerial photographs made by Burton B. Thurber, cameraman. The Oregonian also chartered planes during 1932 so that its flying cameraman could make shots of pursuit group maneuvers near Mount Hood, flood scenes, automobile wrecks, the airship "Akron," a steamship wreck, the American Legion parade, and other news photos near Portland. With Webster A. Jones, aviation editor, Thurber flew 400 miles to obtain photos and the new story of the first American Legion contingent setting foot on Oregon soil.

The Nashville (Tenn.) Banner used specially chartered airplanes to obtain news pictures of the Kentucky Derby for its bulldog edition. The Fort Worth (Tex.) Star Telegram chartered a light airplane in January to obtain a view of a seven-inch rain which flooded the city and sent the Trinity River on a rampage. The Evening News (San Antonio, Tex.) sent its aviation editor, William F. Salathe, on a 200 mile flight to the Mexican border in search of a fugitive charged with shooting a 65-year-old rancher. The fugitive later was brought back for trial and the Evening News had its story. The San Antonio (Tex.) Express used planes to cover an oil well fire and the search for the Mexican fugitive already mentioned.

These are but a few of the highlights of the year's experiences in covering new stories through the use of aircraft. They are interesting as examples of the way in which newspapers are finding air transport facilities to advantage in speeding up their daily task of collecting the news of the world in story and picture.

CHAPTER XIV

AERONAUTICAL LAW AND LEGISLATION

Special Sessions Increase Number of Aviation Bills Introduced in "Off Year"—New Licensing Acts—Gasoline Tax Laws Summarized—Chamber Continues Analysis of All Current Legislation

BECAUSE many state legislatures were called into session during 1932 to consider matters concerned with the current economic situation, there was an unprecedented number of bills affecting aviation introduced in the so-called "off year" for state legislative activity. It pointed to what might be expected in 1933 when 43 of the 48 states were scheduled to meet in regular session.

The Legal and Legislative Bulletins of the Aeronautical Chamber of Commerce, part of the regular bulletin service to members developed by its Legal and Legislative Research Service, reviewed 135 bills introduced in state legislatures during 1932 affecting aviation in some way. Twenty-nine new laws were enacted.

The legislatures of ten states met in regular session during the year: Arizona, Kentucky, Louisiana, Massachusetts, Mississippi, New Jersey, New York, Rhode Island, South Carolina, and Virginia. States called into special session, for the most part to consider questions of revenue and taxation, included: Alabama, Arkansas, Delaware, Georgia, Illinois (four times), Indiana, Maine, Michigan, Pennsylvania (twice), and Wisconsin.

The licensing of aircraft and airmen was made the subject of bills considered in Indiana, Kentucky, Louisiana, and New Jersey. In the last three states named, the bills were passed and became law. The Indiana legislation failed to pass.

The new law in Kentucky, which became effective March 29, 1932, repealed and reenacted the former laws so as to require all aircraft navigated within the state to be licensed and registered by the federal Department of Commerce, and all persons operating aircraft in the state to have a federal license. The law did not apply to public aircraft of the federal government or of any state, territory or possession, or of a political subdivision, or to aircraft licensed by a foreign country with which the United States had a reciprocal agreement covering the operation of such licensed aircraft.

The Louisiana licensing law, which took effect July 7, 1932, required a federal license for all civil aircraft flown in the state and for all airmen of civil aircraft. Civil aircraft was defined to include all aircraft except that used exclusively in the governmental service of the United States.

In New Jersey the new law was necessitated by the decision of a New Jersey court which held the New Jersey Aviation Act of 1931 unconstitutional. The new law accomplished the same results intended by the 1931 statutes and required federal licenses for all aircraft and pilots, except military aircraft of the United States or its possessions, public aircraft of any state or territory, and aircraft licensed by a foreign country having a reciprocal agreement with the United States.

The final result of these legislative efforts was to put Louisiana among the states requiring federal licenses, New Jersey having previously been so classified under regulations judicially determined to be unenforceable, and Kentucky merely re-enacting similar previous licensing provisions. Georgia was the only state which had no licensing law. A table showing in detail the licensing statutes of all other states will be found in Part IV of this volume, "Flying Facts and Figures."

There were but two airport enabling acts passed during 1932, the states being South Carolina and Virginia. In Massachusetts, three bills having a similar purport failed to pass. Airport enabling acts have as their principal object the giving of authority to governmental divisions in the state for the acquisition, operation, maintenance and control of airports and landing fields.

The subject of regulation and promotion of aeronautics received a considerable amount of attention by state legislatures in 1932 and resulted in several interesting laws. In Massachusetts, railroad corporations were authorized to conduct auxiliary transportation operations by aircraft and to own stock in subsidiary corporations organized under Massachusetts law to operate aircraft for the carriage of passengers or freight or both.

Rhode Island created a State Aviation Commission of three persons, to take the place of the State Airport Commission. The licensing bill passed in Kentucky contained provisions creating an "Air Board of Kentucky" and defining its duties, while New Jersey's new licensing statute created a Department of Aviation for the state with definite duties. New York extended the life of its State Commission of Aviation to April 1, 1933. Another new law in New York related to test flights of aircraft and still another to the preservation of evidence in the case of wrecked aircraft. In Virginia, a new law was concerned with the protection of bailors of aircraft.

There were few legislative efforts on the subject of appropriations for aeronautics, although four states provided funds. In Virginia, the General Appropriation Bill contained an item of \$25,000 for establishing airports

on land donated by localities. This was in line with programs already established in Tennessee, Michigan and Idaho. Another Virginia law authorized the use of a part of the military reservation at Virginia Beach for aviation purposes. The New York law extending the tenure of the State Commission of Aviation carried an appropriation of \$15,000 for its use; and in Rhode Island, a total appropriation of \$82,500 was made for the use of the State Aviation Commission for the period ending June 30, 1933. In Alabama \$142,000 was provided for the air service of the National Guard, with \$140,000 of that sum to be reserved for use during the year beginning October 1, 1934.



AUTOGIRO'S INVENTOR HONORED

Juan de la Cierva (center), inventor of the autogiro, receiving the John Scott Medal from Dr. Louis Heiland, with Harold Pitcairn, autogiro manufacturer.

The subject of taxation, in various forms, received considerable attention. Eighty-four such bills were introduced during 1932, most of them having to do with the gasoline tax. For purposes of brevity, only those bills passed will be reviewed here, and a comprehensive summary of the state gasoline tax situation as it affects aviation in each state will be found in Part IV of this volume, "Flying Facts and Figures."

In Pennsylvania, an emergency sales tax was imposed upon sales of tangible personal property. In Louisiana, the state parishes, excepting Orleans, were authorized to levy and collect one cent per gallon on all gasoline used or consumed within their respective territorial limits. Mass-

achusetts extended until April 30, 1936, the time within which an additional excise tax of one cent per gallon might be collected.

In Mississippi, all but one cent per gallon could be refunded to consumers not using the taxed gasoline in motor vehicles on the public highways. The Maine law taxed gasoline four cents per gallon with a refund as to aviation fuel of three cents per gallon. In New York, the gasoline tax was increased one cent per gallon for the period ending June 30, 1933. In Arizona, the tax was made five cents per gallon to June 30, 1933, and thereafter four cents, with a refund available for aviation use.



SOARING FROM ELMIRA'S HILLS

American soaring enthusiasts better previous performances in 1932 meet staged at Elmira, N. Y., mecca for soaring pilots.

Alabama passed three such laws. One removed the power of the Court of County Commissioners to collect a 2 cent tax; another empowered the Court in Crenshaw County to levy a tax of 1 cent per gallon; and the third imposed an excise tax, in addition to all others, of 1 cent per gallon, upon the business of selling, distributing, refining, storing, or withdrawing from storage gasoline in the state.

New York was the only state to bring up the subject of liability to persons or property on the ground, and none of the bills considered succeeded in passing. The subject of what liability should be imposed by law upon the owners or operators of aircraft for damage to persons or property on

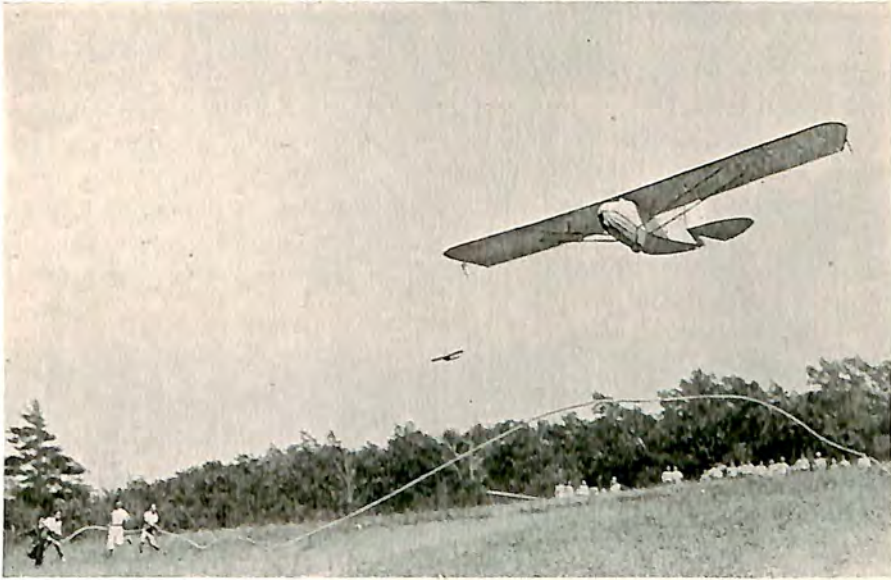

JERKED INTO THE AIR

Franklin utility glider being launched on soaring flight during Third Annual National Soaring Meet at Elmira, July 11-24.



JUST A LITTLE HANGAR FLYING

Corner of the living room in the Pylon Club on Patco Field near Philadelphia, providing cozy quarters for the sportsman pilot.

the ground continued to be an important one under consideration of the Aeronautical Committee of the American Bar Association.

No insurance bills affecting aviation were introduced during the year, and only a few bills of a type not readily classified under the major headings—licensing, airport enabling acts, regulation and promotion, taxation, appropriations, and liability—were considered. In New Jersey, an unsuccessful attempt was made to permit the use of bonds for equipping airports. In South Carolina, a bill which failed provided for roads to connect airports with public highway systems and for highway markers and signals to guide aircraft.



NEW AVIATION COUNTRY CLUB

Another unit in the chain of clubs for sportsmen fliers, the Philadelphia Aviation Country Club at Wings Field is opened.

Rhode Island attempted to make kidnapping by aircraft a criminal offense. New York memorialized Congress to increase appropriations for the development and improvement of the air forces, considered empowering the Public Service Commission to order changed electrical transmission lines erected within 1,000 feet of an airport and constituting a menace to aircraft, and defeated bills requiring passenger aircraft to have at least two exits and a parachute for each person carried. Massachusetts endeavored to restrict the acquisition of certain rights in connection with the passing of aircraft over the lands of others.

As a further effort to keep its members in touch with legal and legis-

lative developments, the Legal and Legislative Research Service reported periodically by bulletin on aeronautical legislation in Congress, and also on court decisions and judicial rulings affecting aviation. The principal bills affecting aviation enacted into law by the first session of the Seventy-second Congress were concerned with appropriations for the Post Office, War, Navy, and Commerce Departments and the National Advisory Committee for Aeronautics. Appropriations by Congress for the aviation activities of the federal government from 1922 to 1933 will be found in Part IV of this volume, "Flying Facts and Figures."

The importance placed on the aviation activity of state legislatures during their 1933 regular sessions, when 43 of the 48 states were scheduled to be active, was reflected in the annual conference of the National Association of State Aviation Officials in Nashville, Tenn., early in December, 1932. Official representatives from 21 states were in attendance at the conference, which considered the proper relation of the state to the development of aviation. Richard S. Boutelle of Tennessee was elected National President of the association for 1933.

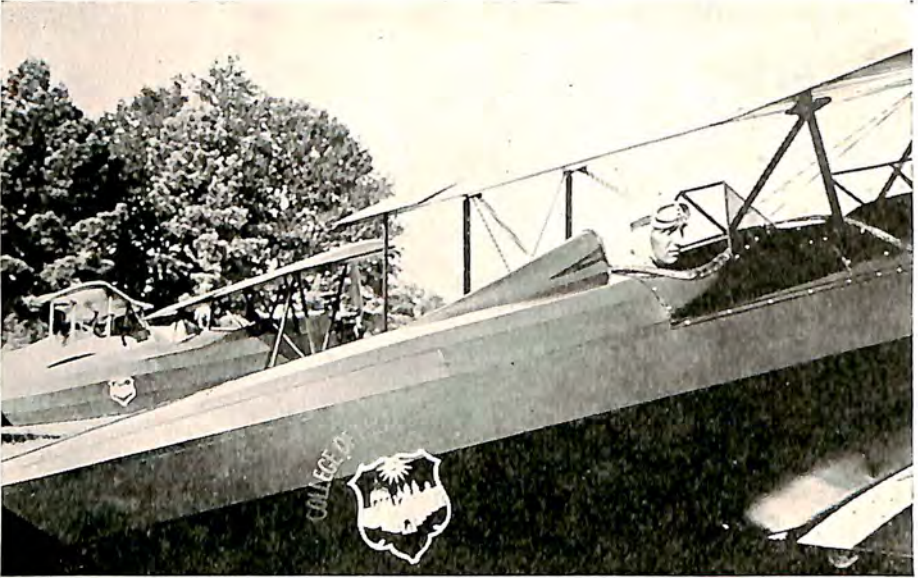

COLLEGE CREDITS FLYING

With college credit offered to students who learn to fly, these planes are used by students at William and Mary.

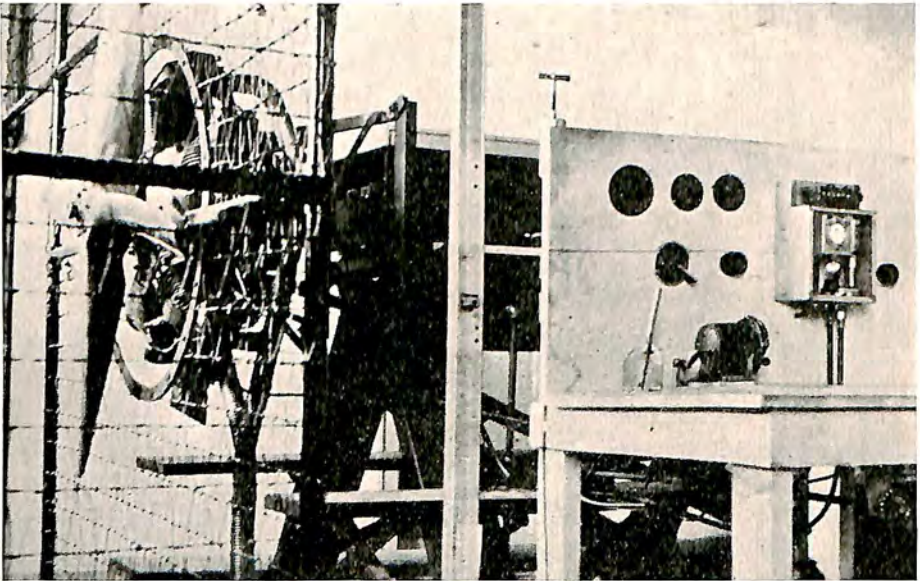

IOWA STATE LABORATORY

Air-cooled engine mounted on a torque stand at Iowa State College ready for students to run tests on it.

CHAPTER XV

EDUCATION TURNS SKYWARD

Aeronautics Courses Attract Thousands of Students—Enrollments Larger In Thirty-three Universities—Seventeen Award Degrees In Aeronautics—Many Faculties Approve Flight Training

WITH one out of every seventy students registered in American universities and colleges during 1932-33 enrolled in a course specifically devoted to some phase of aeronautics, the place of aviation in the college and university curriculum was established. This does not take into consideration additional thousands who studied some facts about this new industry in such general courses as economics, industrial history, physics and law, nor those who turned to flying as an extra-curricular activity.

In the field of elementary and secondary education, appropriate provision for study of aviation was being provided through courses which ranged from simple elements taught in the kindergarten to well-rounded vocational courses in certain trade and high schools.

The widespread interest in aviation and the concerted effort of most educational institutions to provide the student with up-to-date information on the new field taxed the industry and the educator alike. In the grades and high schools particularly, textbooks generally used in industrial history, civics, economics and similar fields were obsolete so far as up-to-date information on this growing industry was concerned. This presented an added problem for the educator, making it necessary for each teacher to be on the alert to temper textbook information with new facts on this rapidly changing field. It challenged the industry itself, and emphasized the necessity for close cooperation between educators and leaders in the aviation industry if instruction on aviation topics is to keep pace with new developments within the industry.

Eighty-nine universities and colleges throughout the United States were known to include special courses of some kind on aeronautics in their curricula. The tabulated results of the fourth annual nation-wide survey on aeronautical education made by the Aeronautical Chamber of Commerce of America especially for this volume are to be found in Part IV, "Flying

Facts and Figures." This table lists all universities and colleges offering aeronautical courses, the number of full and part-time instructors, and the comparative enrollments for 1930-31, 1931-32, and 1932-33.

Enrollment in aeronautical courses reported by 64 institutions for 1932-33 totaled 6,978 students, an average of 104 per school, as compared with a total of 7,020 students reported by 76 institutions in 1931-32 for an average of 93 per school. In the 17 universities offering full-time courses leading to specialized degrees in aeronautics, enrollment for 1932-33 was



STUDENTS IN WIND TUNNEL

University of Detroit students preparing to test a sphere in the university wind tunnel as part of their course.

on about the same level as 1931-32, with only a very slight decrease. The 17 institutions in this first group had a total enrollment of 3,323 in 1932-33 as compared with 3,374 in 1931-32. Eleven showed substantial increases, while six experienced decreases.

The 17 universities offering curricula leading to specialized degrees in aeronautics include: University of Alabama, California Institute of Technology, Carnegie Institute of Technology, University of Cincinnati, College of the City of Detroit, University of Detroit, Georgia School of

Technology, Massachusetts Institute of Technology, University of Michigan, University of Minnesota, New York University, University of Pittsburgh, University of Southern California, Stanford University, University of Washington, Municipal University of Wichita and Worcester Polytechnic Institute.

Restricted budgets for the 1932-33 academic year show their effect on the number of full-time and part-time instructors devoting their attention to the teaching of aeronautical courses. Sixty-two professors and instruc-



RADIO A MAJOR COURSE

Students practicing code signal reception at Boeing School of Aeronautics, where radio telephony is a major course.

tors were devoting full time to aeronautical subjects in 1932-33 as compared with 86 in the previous year. There were 194 part-time instructors compared to 247 the year before.

Despite the reduction in number of instructors, 33 institutions of higher learning reported enrollments for 1932-33 equal or exceeding those of the previous year. Among them were: University of Alabama, Bradley Polytechnic Institute, California Institute of Technology, University of California, Case School of Applied Science, University of Cincinnati, University of Colorado, College of the City of Detroit, Georgia School of Technology, University of Minnesota, University of Nebraska, University of Nevada, New Mexico College of A. & M.A., New York University, Ohio State

University, University of Oklahoma, Oregon State College, Penn State College, Princeton University, University of South Dakota, Stanford University, Syracuse University, United States Military Academy, Virginia Polytechnic Institute, University of Washington, College of William and Mary, University of Wisconsin, and Yale University.

While more than a score of the major universities offered courses specifically designed to train the student to enter some phase of aviation, usually engineering, as a profession, there was considerably greater emphasis being placed upon the importance of providing the student with an

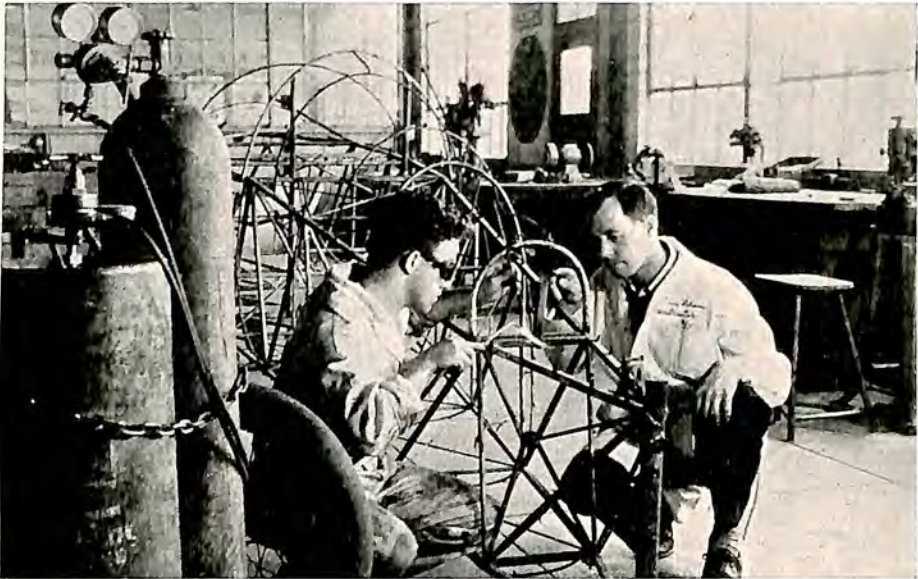

WELDING IMPORTANT COURSE

Student receiving individual instruction in welding in Curtiss-Wright Aviation School as part of ground course.

understanding of the salient features of aviation as it may apply to other fields. Consequently, Air Transportation was included as a part of economics curricula in transportation, Aviation Law as an added feature of advanced Law work, etc.

New York University introduced a unique course in "Contemporary Trends in Aviation," designed to bring to the student a broad picture of aviation today through a series of lectures by 21 prominent figures in the aviation world, including engineers, pilots, executives and specialists. Such a course was expected to meet the need for up-to-the-minute information not found in textbooks, and might offer a pattern for other universities to follow in developing similar courses of a non-vocational nature.

The United States Military Academy continued to give aeronautical instruction to the junior class and the United States Naval Academy provided specific aviation instruction for its three upper classes, designed to generally acquaint cadets and midshipmen with the place and problems of aeronautics in the general scheme.

Flight training under college auspices was offered at only one institution of higher learning, the College of William and Mary in Virginia. This experiment, incidentally by the oldest college in the United States, promised to be one of the most interesting undertaken in aeronautical edu-



MINNESOTA'S FLYING COED

Miss Jean Barnhill, junior aeronautical engineering student at the University of Minnesota, returning from flight.

cation. During 1931-32, the first year the course was offered, 30 students took the flight course and 24 qualified for pilots' licenses. A summer session in 1932 found 35 students enrolled, a limit set by the college. For the 1932-33 term, the limit was set at 25 and enrollment quickly completed.

The College of William and Mary owns its own flying field, one mile from the campus, operates a \$10,000 hangar, with shops and offices, and has four airplanes for student flight instruction. A "laboratory" fee of \$125 is charged for the flying course, which includes ten hours of dual and ten hours of solo flying. The ground school course, a pre-requisite to flight training, is offered with a fee of \$5 per semester. These fees were far below those of commercial schools, since the college subsidizes the

courses just as it does other branches of instruction. The courses were not designed primarily as an introduction to aviation as a profession, but because college authorities are convinced that aviation is destined to take an increasingly important part in the business and cultural interests of all and that the college is the logical place to offer such instruction.

At least one-third of the institutions reporting to the Aeronautical Chamber of Commerce in its fourth annual survey indicated that while they do not provide flight training under college auspices, the faculty is favorable to such training being taken by students at qualified commercial



WIN NEWSPAPER CONTEST

Five of the twelve winners in the Aeronautical Chamber-Hearst Newspapers' aviation contests for students reach Detroit.

schools. This represents a considerable change in faculty attitude from that reported in the first survey in 1929 when very few indicated faculty sanction for flight training. Some still placed restrictions on students desiring flight instruction. The State College of Washington insists on parents' approval, while the University of Iowa limits flight instruction to summer vacation periods. Only two—University of Utah and Lehigh University—indicated that the faculty disapproves flight training during college years.

New facilities and equipment for the use of students in aeronautics courses were added in many schools upon the opening of the 1932-33 term. Six institutions indicated in the survey that they have well-defined

plans for expansion as soon as funds become available. Others indicated they are prepared to expand as rapidly as conditions require. Oklahoma Agricultural and Mechanical College laid plans for a complete aeronautical laboratory housed in its own building. New York University was forced to add an extension to its present aeronautical building to accommodate the increased enrollment in its course in practical assembly and rigging of airplanes.

New courses were introduced in ten institutions, representing important advances in the provision of well-rounded curricula. Cornell, for instance,

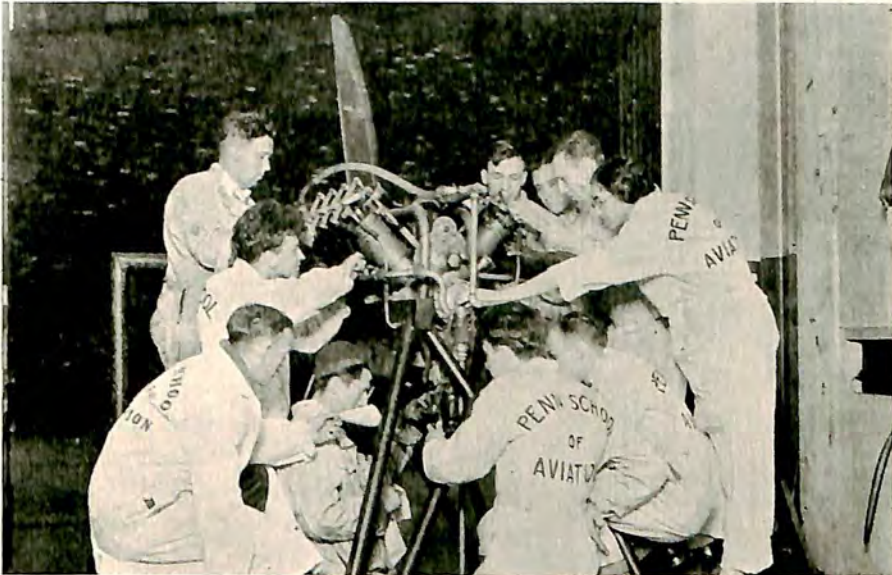

STUDYING AIRCRAFT ENGINES

Students in the Penn School of Aviation at Pittsburgh hard at work on their aircraft engine mechanics' course.

offered its aeronautics course in two semesters instead of one. The University of California added a course in turbulence. The University of Detroit introduced a course on Deisel engine design and the University of Cincinnati added a study of X-ray examination of welds and castings. New York University offered work in airship design and two new courses in maintenance and rigging. Georgia Tech added three courses and Massachusetts Institute of Technology introduced two.

St. John's College of Law in Brooklyn, N. Y., introduced a course in Aviation Law for graduate students only. Undertaken with some misgivings, the course turned out to be the second most popular course offered by the college with 40 registered, about half of the total number of gradu-

ate students matriculated. The University of Minnesota added a correspondence course in elementary aeronautics and the University of Colorado introduced a series of demonstration flights as a new feature of its extension work.

Eight institutions reported aeronautical courses for the first time in the fourth annual survey of the Aeronautical Chamber of Commerce. They were: University of Arkansas, Clemson Agricultural College, Michigan College of Mining, University of Tennessee, St. John's College of Brooklyn, University of Texas, Lafayette, and the University of Toledo. The annual survey is made through questionnaires sent out each year to all universities and colleges regardless of size, a more detailed form being sent to those institutions which reported aeronautical courses in previous years.

The Educational Committee of the Aeronautical Chamber of Commerce, headed by Prof. Roland H. Spaulding, specialist of the Daniel Guggenheim Fund Committee on Elementary and Secondary Aeronautical Education, continued its work of cooperation with universities, colleges and school boards requesting information on aeronautical training. The Committee held its annual meeting in Detroit during the National Aircraft Show and devoted a major portion of its program to a discussion of raising the standards of ground school vocational training for aircraft and engine mechanics.

CHAPTER XVI

AVIATION IN THE WESTERN HEMISPHERE

Air Lines Under Many Flags Serve Nations In Western World—Pan American Airways Makes Great Strides—Year's Progress Shown In Twenty-five Countries—Military Aviation Important

WELDING together a vast system of air line networks under a dozen different flags, the Western Hemisphere enjoyed unusual advantages for the swift transportation of passengers, mail and goods from the frozen land of Alaska, within the Arctic Circle, to the outposts of civilization in southern Argentina. American, French and German interests worked side by side with other companies sponsored by several Latin American governments to speed trade throughout the Americas, and to provide an intermingling of culture which was bound to result in an even closer and more friendly relationship between the many nations in the Western Hemisphere.

More than 74,000 miles of airways were in use during 1932 in the Western World, turning weeks of travel into days and days into hours. Perhaps the most significant event of the year was the linking of all American-owned international airways outside the continental limits of the United States into a single operating unit. It assured unity for the American plan to provide trade routes by air from the United States to all parts of the hemisphere, and later to Europe and the Orient. The French and German enterprises, likewise, were active in the development of air trade routes from the principal South American countries directly to Europe across the South Atlantic. The several other air line networks under the flags of Latin American governments were devoted chiefly to the development of air transportation within their national boundaries or to neighboring countries.

Recognition of the important place of aircraft in the building up of adequate national defense constituted another outstanding development in the progress of aviation in Latin America during the year. The use of military planes in a score of leading skirmishes resulting from revolutionary movements in South America emphasized the potential power of air

forces in dealing with local emergencies. The result was the purchase of up-to-date military planes, chiefly from the United States, to supplement the equipment of several South American nations.

While private flying for sport and business still remained to be developed to its fullest extent, there were some important advances in this field, particularly in Canada and Argentina. It should be interesting to get a glimpse of aviation activity throughout the Western World, outside the continental limits of the United States, as it existed at the close of 1932.

With the acquisition and unification of the Alaskan air lines by Pan American Airways, Inc., one unified system under the American flag was in operation over 25,000 miles of airways extending from within the Arctic Circle on the north to Buenos Aires in Argentina. Pacific Alaska Airways, Inc., a new Pan American subsidiary, took over the lines formerly operated by Alaskan Airways, Inc., as a division of the Aviation Corporation on September 1, 1932, and Pacific International Airways, Inc., a pioneer Alaskan operation owned by Edward H. Lowe, jr., of Grand Rapids, Mich., and San Francisco, Cal., was acquired October 1, 1932.

Previous to the Alaskan acquisition, Pan American had announced the purchase from North American Aviation, Inc., of its Cuban operating unit, Compañía Nacional Cubana de Aviación, on March 1, 1932, to link all important industrial cities of the island with Havana. An independent operating unit, the Cuban company was coordinated with Pan American operations, improving international and internal schedules. Similar relations with the newly established Uraba, Medellin and Central line or "UMCA" provided the first direct rapid international connections for a rich coffee and gold district of Central Colombia. The Pan American system of operations was used as a standard. Starting at Medellin and connecting the interior with the seacoast at Turbo on the gulf of Uraba, the line connected directly with Pan American at Cristobal, offering ready access to Central America, Mexico and the United States. The "UMCA" line also worked closely with the Sociedad Colombo-Alemana de Transportes Aereos or "SCADTA" lines, permitting travellers from the North to visit internal Colombia and then make connections with Pan American-Grace or "Panagra" planes down the west coast of South America.

To round out its operations in the Caribbean region, Pan American extended its service from San Juan, Puerto Rico, to reach Ponce on the south side of the island, and also established a service to St. Croix via St. Thomas, Virgin Islands. Ponce was 75 minutes from San Juan by air against eight hours of ordinary travel. St. Croix was 95 minutes by air from St. Thomas.

By diverting one of the three weekly round-trip flights from Miami to San Juan by way of Kingston, Jamaica, Pan American provided more direct connections throughout the islands, giving the eastern Indies direct

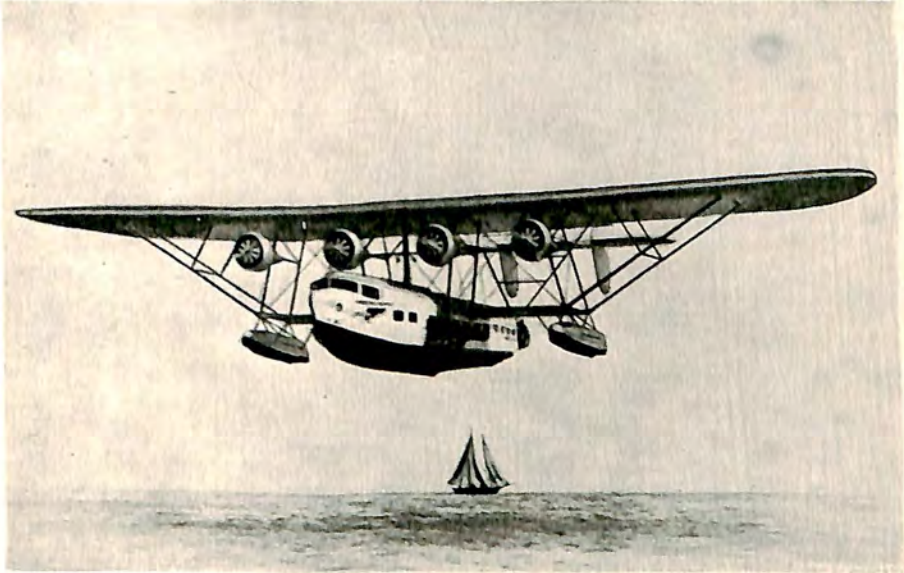

CLIPPERS OF THE SKIES

Giant Hornet-powered Sikorsky S-40 flying boat "American Clipper" links North and South American continents.

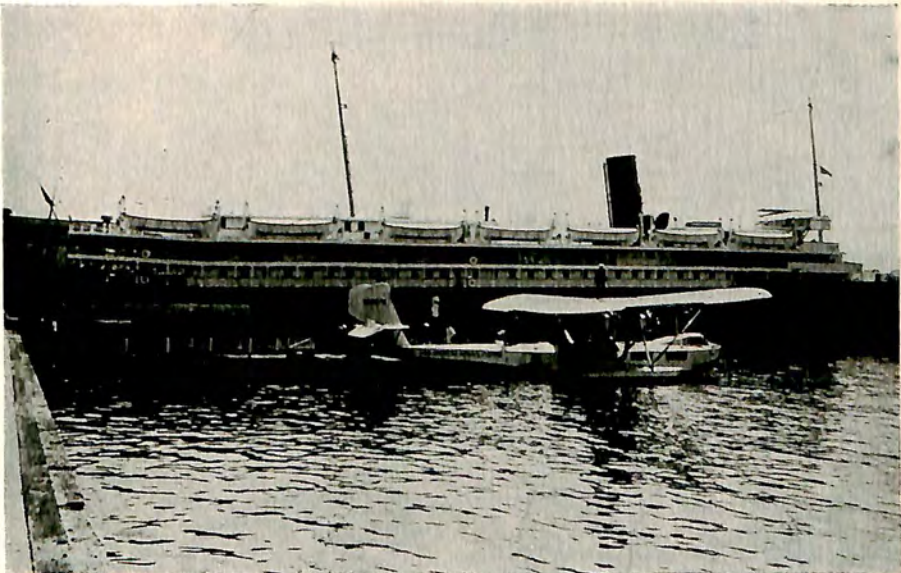

MIAMI TO MONTEVIDEO

Hornet-powered Consolidated Commodore flying boat of Pan American Airways at end of 7,500 mile flight to Uruguay.

routes to Panama and Barranquilla, and providing faster service to the other British possessions in the islands.

Another development regarded as highly significant was the negotiation of a contract for year round air mail service to Nassau, capital of the Bahamas which had enjoyed only winter service previously. During the winter season daily service was to be provided, and during the remainder of the year schedules were twice weekly.

Next to the Caribbean region, the most important extensions of air service in Latin America were in Mexico where a new company, Aerovias Centrales, S. A., opened 1,290 miles of lines when it began operations November 5, 1932, to provide an airway through Mexico to the western part of the United States. The main route extended from El Paso, Tex., to Mexico City via Chihuahua, Torreon and Leon. A branch line from Torreon reached through Durango to Mazatlan on the Pacific Coast. Aerovias Centrales' service was coordinated to provide direct connections with the Pan American System for travellers headed south and east of Mexico, saving about 1,000 miles of travel for west coast passengers to the West Indies, Central and South America.

Wherever new services were established, whether owned by Pan American or affiliated companies, they were coordinated to provide one operating unit for passenger, mail and express service. Many schedules were revised to speed up the service, and new equipment was added to permit the shortening of lines by over-water hops and to supply the needs of growing traffic.

As an example of the new equipment necessary, three of the giant 44 passenger Hornet-powered Sikorsky S-40 flying boats of the "Clipper" class were put into service in little more than a year. The third plane, named "Southern Clipper," joined her two sisterships, "American Clipper" and "Caribbean Clipper" in 1932. Two of the huge flying boats were assigned to the flight from Miami to Barranquilla, including the longest over-water hop on any air line in the world, between Kingston, Jamaica, and Barranquilla, Colombia. The third one was assigned to the Miami-San Juan run. Operation of these giant flying boats in service brought Pan American a step closer toward realization of another phase of its international air route development, the spanning of the Atlantic and Pacific to Europe and the Orient. Late in 1932, orders were placed with the Sikorsky Aviation Corporation and the Glenn L. Martin Company contracting for the immediate construction of two giant four-engined flying boats capable of carrying a load of 50 passengers, mail and express over distances up to 3,000 miles.

Another great technical development of the year was the adaptation of 1,200 miles of lines in the West Indies to the use of flying boats instead of land planes, making a total of 16,000 miles of routes under marine



THROUGH MIRROR WATERS

Pan American Airways' huge Hornet-powered Consolidated Commodore with 22 passengers aboard takes off from turquoise sea.

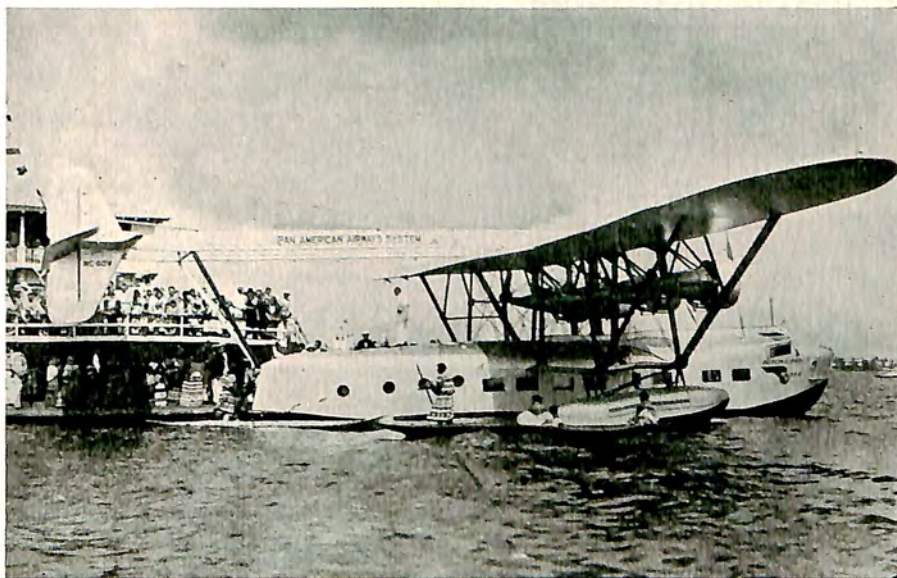

SEMINOLES GREET "WATER BIRD"

Seminole Indians in full tribal costume turn out to greet the Hornet-powered Sikorsky S-40 at Dinner Key marine base.

operation. The decision meant the abandonment of the Pan American Airport at Miami as a northern terminus for the system and the building of the world's largest marine air terminal at Dinner Key on the outskirts of Miami. The Pan American Airport was converted into a maintenance base for the flying equipment of the entire system, including the Pan American-Grace trunk line down the west coast of South America. The magnitude of this operation, as well as a vivid picture of the other air lines operating in the Western Hemisphere, can be obtained from a study of the accompanying maps in this chapter.

Through two hurricanes in Puerto Rico and Cuba, Pan American continued the relief measures which won such wide international goodwill in past years. Having constructed its buildings to withstand hurricane weather, Pan American was able to send minute-by-minute reports from the scene of devastation when the hurricanes were in progress. Other communities were warned, and Pan American's planes were turned to good use in carrying doctors, nurses and medical supplies to the stricken areas.

The extensive air line network within the continental limits of the United States was linked not only with Pan American's connections for the countries to the south, but also with Canada through a line operated by Canadian Colonial Airways, Ltd., from New York and Albany to Montreal and by an extension of Northwest Airways, Inc., from Pembina, N. D., to Winnipeg, Canada. It should be interesting to get a glimpse of the activity within Canada's own national boundaries.

Canada, suffering a severe setback in 1932 as a result of the sharp curtailment of scheduled air mail routes within the country itself, nevertheless continued the operation of eight contract air mail routes by its two operating companies. In addition to the Montreal to Albany service provided by Canadian Colonial Airways, Ltd., six other routes were operated by Canadian Airways, Ltd., namely: Amos-Siscoe; Sioux Lookout-Narrow Lake; Prince Albert-Lac La Ronge; Vancouver-Victoria; Winnipeg-Pembina; and Fort Murray-Aklavik. The Royal Canadian Air Force also maintained service from Montreal to Rimouski to speed mails on the arrival and departure of trans-Atlantic steamers. While in 1931 seven operating companies were maintaining mail service on 20 routes, the cut in appropriations meant a consequent reduction in the first quarter of 1932 to 15 scheduled air mail services. The closing of five lines operated only during the winter and indefinite suspension of two others cut the number operating on June 30 to eight. The winter services operated each year when marine navigation is impossible include: Leamington-Pelee Island; Moncton-Magdalen Islands; Moncton-Charlottetown; Quebec-Seven Islands; and Seven Islands-Anticosti. Thirty-two planes, chiefly American and British, and 41 pilots were used on the 1932 routes, which totaled 348,330 miles flown with 739 revenue passengers, 227,839 pounds of mail, and 1,935 pounds of express

AIRWAYS IN SOUTH AMERICA

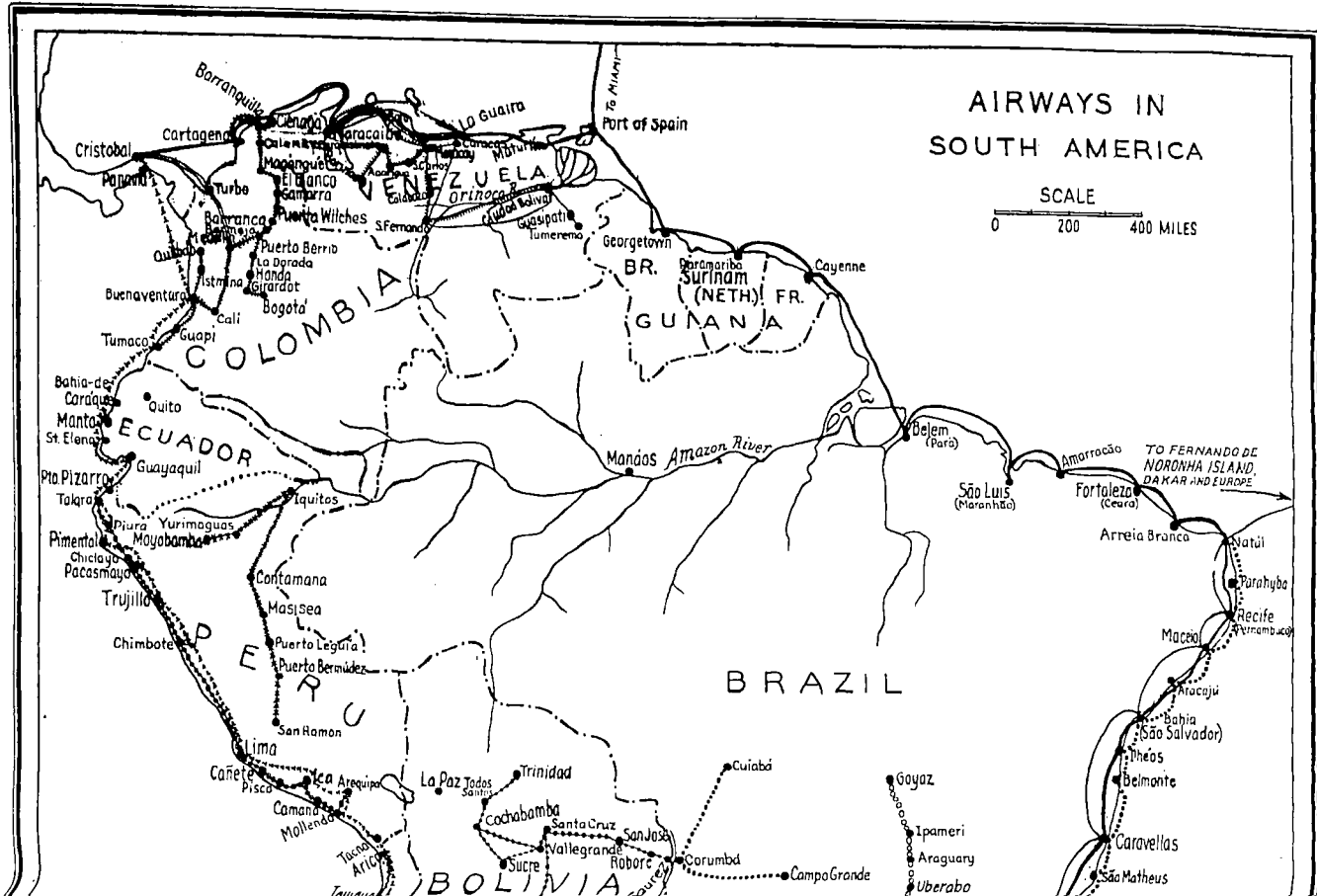
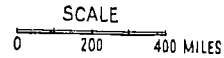



AIR LINES IN SOUTH AMERICA
Prepared for
"The Aircraft Year Book for 1933"
by
Aeronautics Trade Division
Bureau of
Foreign and Domestic Commerce

- PAN AMERICAN AIRWAYS
- AEROPOSTALE COMPANY
- LLOYD AERO BOLIVIANO
- "SCADTA" COMPANY
- CHILEAN NATIONAL AIRLINES
- CONDOR LINES
- FAUCETT AVIATION COMPANY
- PERUVIAN NAVAL AIR LINE
- PAN AMERICAN-GRACE AIRWAYS
- URUBA MEDELLIN AND CENTRAL AIRWAYS S.A.
- XXXX EMPREZA DE VIACAO AEREA RIO GRANDENSE S.A.
- OOOO BRAZILIAN GOVERNMENT
- VENEZUELAN LINE
- BOUNDARY IN DISPUTE
- ⊥ INDICATES PROPOSED AIR LINES
- ⊥ " SUSPENDED AIR LINES

AIRWAYS IN CANADA AND NEWFOUNDLAND

Prepared for
 "The Aircraft Year Book for 1933"
 by
 Aeronautics Trade Division
 Bureau of
 Foreign and Domestic Commerce

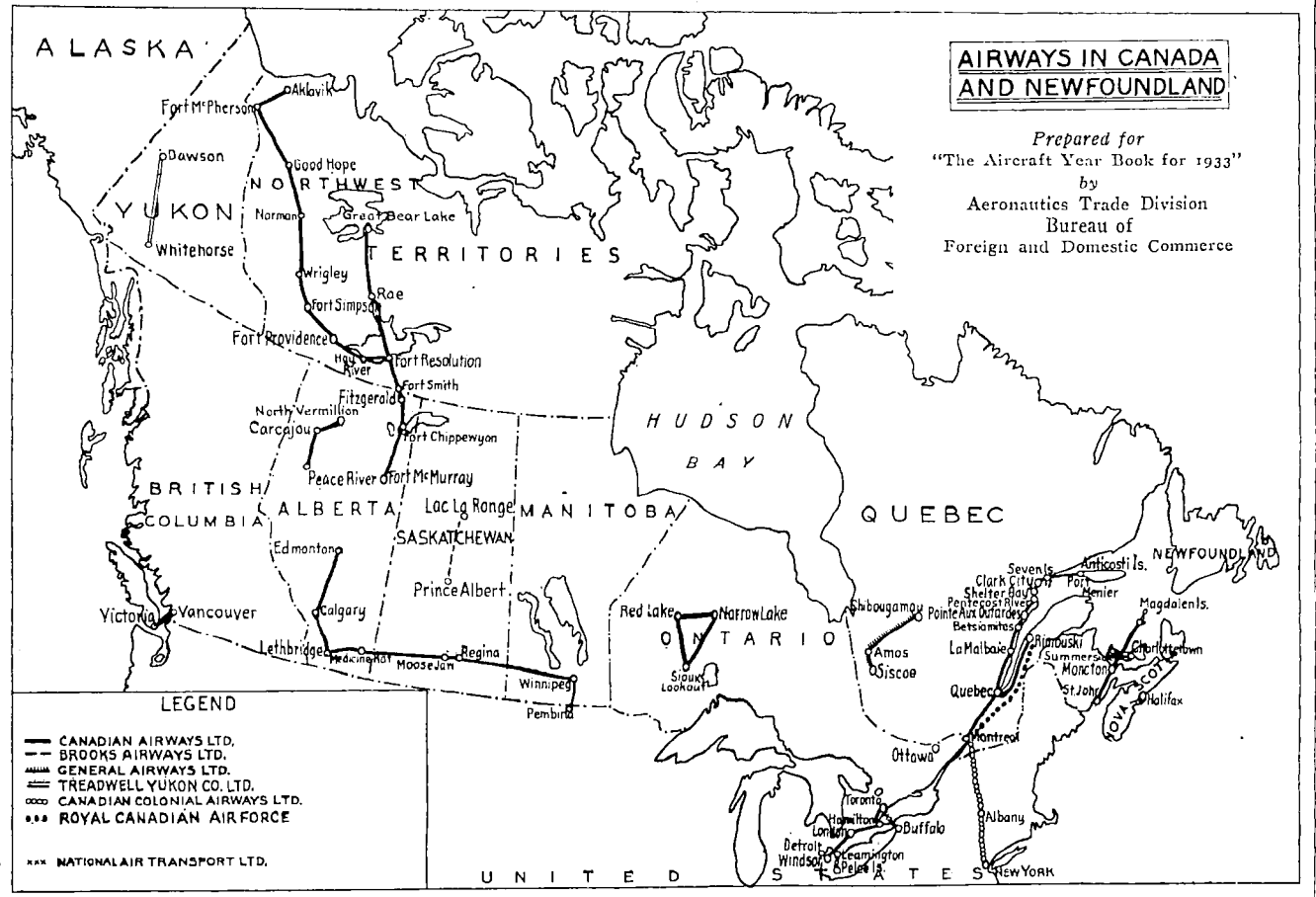

LEGEND

- CANADIAN AIRWAYS LTD.
- - - BROOKS AIRWAYS LTD.
- ▨ GENERAL AIRWAYS LTD.
- ▤ TREADWELL YUKON CO. LTD.
- CANADIAN COLONIAL AIRWAYS LTD.
- ▲▲▲ ROYAL CANADIAN AIR FORCE
- * * * NATIONAL AIR TRANSPORT LTD.

UNITED STATES NEW YORK

8

AIR LINES IN MEXICO, CENTRAL AMERICA, CUBA AND WEST INDIES

Prepared for
"The Aircraft Year Book for 1933"
by
Aeronautics Trade Division
Bureau of
Foreign and Domestic Commerce

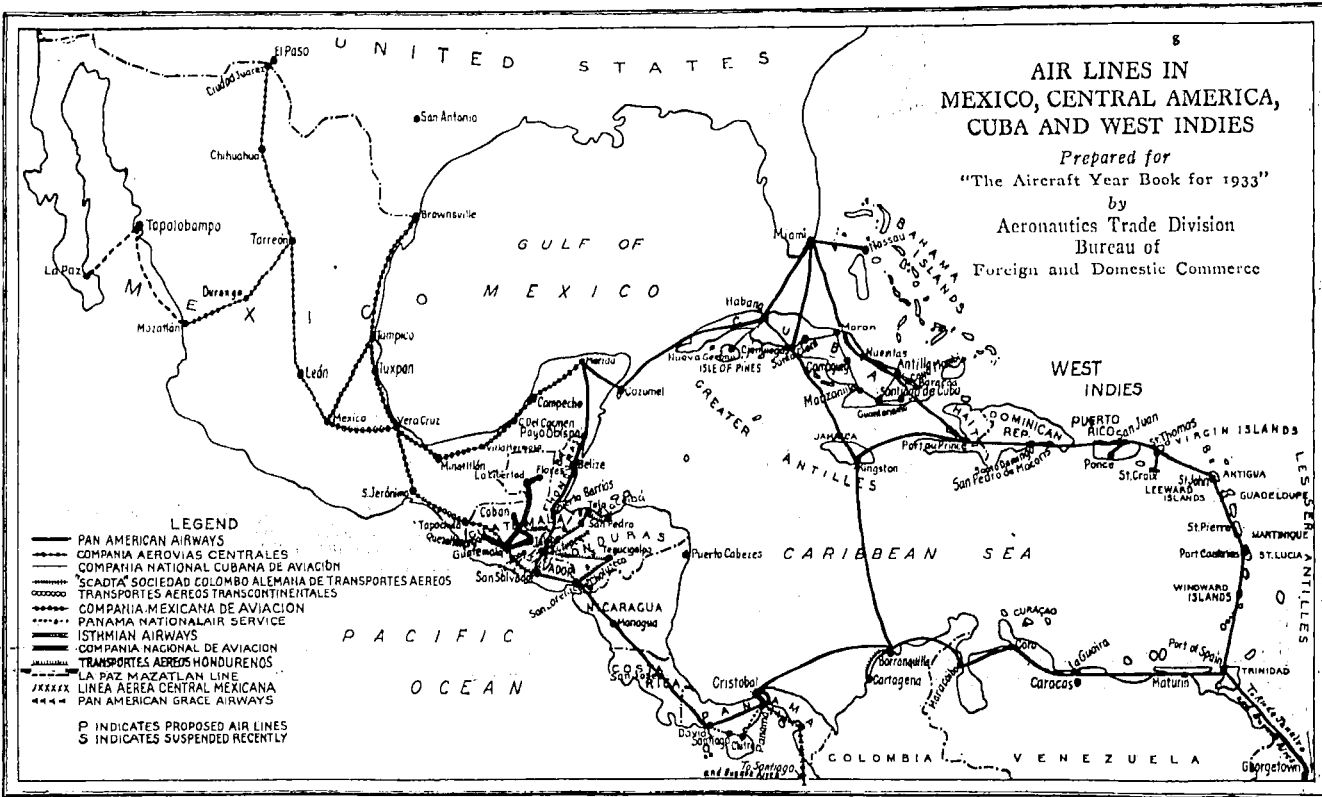

during the first six months of the year without a fatal accident. The cost of air mail service to the Dominion for the six months was \$216,510 as compared with \$1,090,487 in the calendar year 1931. The Dominion also appropriated \$500,000 in 1932 for the construction of 25 emergency landing fields to reduce unemployment and carry out one stage of a plan for the trans-Canada air route. Although 48 airplanes with a total value of \$412,000 were produced in Canada in 1931 by the seven aircraft manufacturers in operation, production was virtually at a standstill in 1932 because of reduced government subsidies and appropriations for military aircraft.



AIR MAIL FOR BAHAMAS

Governor Edmund Hugh Clifford of the Bahamas holding flags attached to first air mail delivered in Nassau.

The Dominion reported on June 30, 1932, to have 313 private pilots, 454 commercial pilots and 367 air engineers licensed, as well as 44 private certified aircraft, 287 commercial aircraft, and 86 licensed airports. Most of the 23 light airplane flying clubs operating in 1931 continued their programs in 1932, having a total membership of 2,915. Seventy-two planes were used with 673 persons under instruction. Perhaps the most notable exception to a general decline of activity due to economic conditions was the increased use of aircraft to fly miners' supplies into inaccessible regions. During 1932 it was estimated that no less than 1,200 tons of freight were moved in this way during the season. Aside from the flight of the Royal Canadian Air Force with mails from trans-Atlantic steamers to the Imperial Economic Conference at Ottawa, there were no outstanding developments in Canadian military aviation during the year.

From this and preceding chapters we have been given a picture of aviation in the northern part of the Western Hemisphere—Alaska, Canada, and the United States. It should be interesting now to turn to the countries of the Caribbean, Central and South America to obtain a glimpse of the year's events there other than those already mentioned in the general description of air line development throughout the Americas. For convenience in future reference, each country will be listed alphabetically.

Argentina had an opportunity to realize the full benefit of its air transport service rendered by Pan American-Grace Airways across the high Andes to Chile, when the Transandine Railway suspended operations April 20, 1932, because of a dispute over Chilean cattle tariffs and remained inactive until late fall. For months the only link between Argentina and its neighbor to the west was by air, and additional planes were added to meet the increased traffic demands. Reduction in the National Government's appropriations to the Direccion de Aeronautica Civil, government bureau controlling civil aviation, from 500,000 paper pesos to 170,000 paper pesos threatened the life of Argentina's own nationally-owned air lines in 1932 and curtailed funds for the civil aero clubs for the promotion of private flying. The short passenger and freight line operated by the Bureau from Bahia Blanca to General Lavalle was suspended, and its unique line from Bahia Blanca to Rio Gallegos in southern Patagonia, often thought of as the world's last outpost, was threatened until the French-controlled company, Compagnie Générale Aéropostale, stepped in and guaranteed a limited operations deficit each month to insure continuation of the line to the isolated southern regions. The National Government established a new line from Tucuman to Tafi del Valle during the year to provide a half-hour service to an important sugar and wine growing district which previously required two to three days by cart. The government-owned and operated aircraft factory at Cordoba was reported to have produced 20 Dewoitine single-place pursuit planes and 10 two-place biplane trainers for the Air Force in 1931. As can be seen from the accompanying map, Pan American Airways (American), Aéropostale (French) and the Condor Syndicate (German) provided the principal services to Argentina.

The **Bahamas** obtained their first air mail service to the United States in 1932 with the signing of a contract between the Bahamas Government and Pan American Airways for daily service during the winter months and semi-weekly service during the summer between Nassau and Miami. There were no private planes or other aviation activity in the British-owned islands.

Bolivia's principal aviation activities were centered in its air line, the Lloyd Aereo Boliviano, which was managed by Germans with the Bolivian Government holding more than 50 per cent. of the stock. Five Junkers planes were used on charter and air line trips, one of them maintaining



OVER GUATEMALA PALACE

Tri-motored transport of Cia. Nacional de Aviacion flying over colonial palace in Antigua, Guatemala.

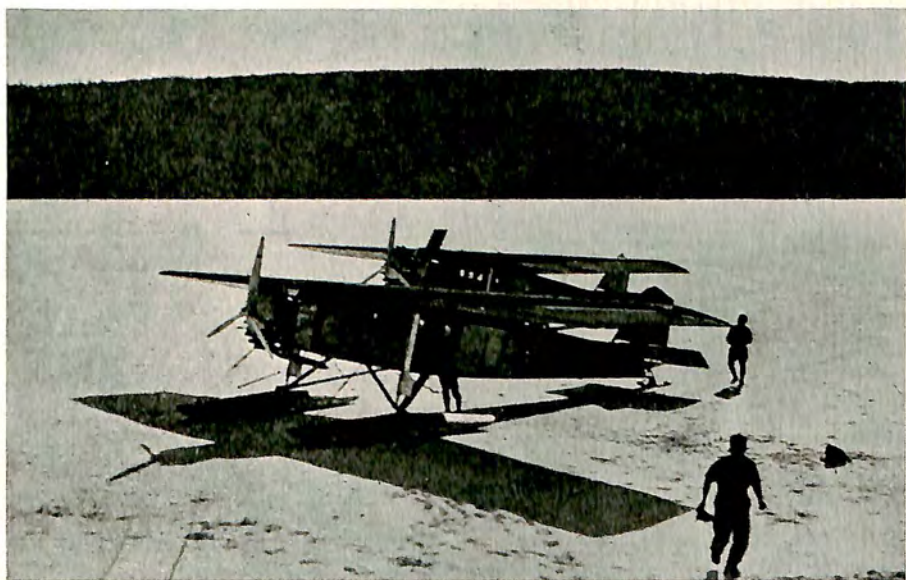

OVER CANADA'S SNOW AND ICE

Hornet-powered Hamilton metal planes do heavy duty in Canada, taking on cargo at Longlac.

the scheduled service from Puerto Suarez to Cochabamba via Santa Cruz. In June, 1932, the company resumed a service to Arica, Chile, for connections with Pan American-Grace, but discontinued the service after a few flights. During the first nine months of 1932, the Bolivian company carried 19,608 passengers on 5,407 flights for a total duration of 7,417.26 hours. The military conflict with Paraguay, which broke out in the late fall, resulted in a disruption of service causing considerable irregularity in service since the five planes of the company were put to military tasks. Due to a lack of experienced pilots only three planes could be put into the air at the same time. There were 40 airports and 35 emergency landing fields in the country.

Brazil's commercial air lines enjoyed rapid increases in traffic during 1932 as indicated from the report for the first six months of the year by the Ministry of Communications showing 4,322 passengers, 34,101 kilos of mail, 66,784 kilos of express, and 47,592 kilos of freight carried a total of 1,061,967 kilometers. In the first six months of 1931, the figures were: 1,919 passengers, 21,459 kilos of mail, 9,047 kilos of express, and 14,333 kilos of freight flown a total of 892,309 kilometers. Panair do Brazil, subsidiary of Pan American Airways, started its flights early in the year over the new extension from Santos to Montevideo, the filling of this link having completed Pan American's circuit around South America. Condor Syndicato Ltda (German) and Aéropostale (French) continued their services as indicated on the accompanying map without change during the year. In cooperation with the Condor Syndicate, the "Graf Zeppelin" was able to speed German mails to Rio de Janeiro in four days on several of its nine round-trips from Germany in 1932. The political revolution in the State of São Paulo against the Brazilian Federal Government (July to October, 1932) afforded the Army Air Service an opportunity to demonstrate its usefulness, with the result that the Ministry of War decided to further build up its military air service. Airplanes delivered and orders placed in 1932 for the Army and Navy air services totaled 145, of which all but 57 were manufactured in the United States. Twenty Fairey Gordons and 37 de Havilland Moths of British manufacture constituted the only planes purchased outside the United States. Boeings, Voughts, Bellancas and Wacos were included among the American planes delivered. Following the cessation of fighting, it was learned that six Curtiss Falcons had found their way into São Paulo, but they arrived there in time to take part only in the last three weeks of fighting. One of the planes had been destroyed, and the Federal Government seized the remaining five at the close of hostilities. During the revolution, the military air mail service, maintained with planes and pilots from the Federal military air service between Rio de Janeiro and São Paulo, was interrupted, but steps were made to reorganize the service immediately after the cessation of hostilities.

British Honduras continued to enjoy air transport service to all parts of the Western Hemisphere through the weekly service of Pan American Airways on its Merida-San Salvador section. The Compañía Nacional de Aviación, Guatemala's air transport line, announced plans for the extension of its Flores-Guatemala City service to Belize, British Honduras. To this end, the company was seeking permission to use a plot of land on the outskirts of Belize as a landing field, and was expected to ask the Government of British Honduras for an air mail contract. American planes and pilots would be used on the proposed extension.



FIGHTING PLANES FOR VENEZUELA

Three Whirlwind-powered Curtiss Wright Osprey fighting planes, bought by Venezuela, in flight formation.

Chile found aviation playing a definite part in its political life during 1932. With the suspension of the Transandine Railway, the air lines served as the country's only link with Argentina. Like Peru, Chile found air travel well adapted to its needs, both within the country and in contact with neighboring countries. Chile, however, had no back country like Peru, eliminating the necessity of crossing the continental divide except when going to Argentina. Scheduled air services in Chile included the bi-weekly Pan American-Grace Airways, the bi-weekly Línea Aérea Nacional, and the Compagnie Générale Aériopostale. The National Air Line used four Wasp-powered Fairchild's and a Wasp-powered Ford to maintain its service north of Santiago. The Aériopostale service to Argen-

tina was very irregular during 1932, placing the major traffic burden on Pan American-Grace. The Curtiss-Wright Corporation's branch factory at Santiago produced ten military planes of the Hawk and Falcon type and one commercial plane during the year. The military planes were reported to be for the air force of Paraguay. The Chilean Air Force was equipped with Curtiss Hawks and Falcons as standard types.

Colombia's oldest air line, "SCADTA," continued to operate its system of national air lines which included the Magdalena River Line from Barranquilla to Bogota, 630 miles; the Transversal Line from Puerto Berrio to Medellin, Cali, and Buenaventura on the west coast, 381 miles; from Buenaventura to Tumaco, 200 miles; from Buenaventura to Quibdó, 180 miles; from Barranquilla to Cartagena, 75 miles; and from Barranquilla to Ciénaga, 40 miles. The former service on the Interocean Line from Barranquilla to Buenaventura was suspended, and the traffic transferred to the Transversal Line. The company had contracts for mail, passenger and express routes with the Republics of Panama, Ecuador and Venezuela, as well as with most European countries. Twenty-one seaplanes, land planes and amphibians were used on the routes over which 624,258 miles were flown in 1931 with 5,681 passengers, 81,867 pounds of mail, and 276,170 pounds of express. In the first six months of 1932, 311,781 miles were flown with 3,607 passengers, 35,843 pounds of mail, and 232,161 pounds of express. Ten pilots and 150 other employees constituted the company's personnel. Through the operating agreement with Pan American Airways, "SCADTA's" services were closely coordinated with the twice-weekly service from Colombia to the United States. The inauguration of service in Colombia by "UMCA," a new operating subsidiary of Pan American Airways, was described earlier.

Costa Rica through the Republic's President signed a five-year contract for the transportation of air mail on July 20, 1932, with two Americans. It was reported that the promoters were unable to inaugurate the service within the 60-day period stipulated in the contract due to the failure of communities along the proposed route to complete landing facilities. A reorganization of the concern and the acquisition of capital for the purchase of new American airplanes was expected. Peter Dmitri Ivanoff arrived in the country during the year with plans to establish an aviation school.

Cuba obtained improved service during the year as a result of the acquisition of the National Cuban air mail and passenger service, formerly controlled by North American Aviation, Inc., by the Pan American Airways, Inc. This development already has been described. The result was a change in the itinerary for the national line with stops at Manzanillo and Bayamo substituted for previous stops at Victoria de las Tunas and Holguin, and the service was extended to Guantanamo. The company's routes in Cuba totaled 739 miles. The Cuban Army air force was equipped with

modern American planes and well trained pilots. Several of its officers made extended flights in 1932 from Havana to Mexico City and to various points in the United States via Guatemala and Mexico. The extent of Cuba's air line system is seen quickly from the accompanying map.

Dominican Republic continued to be served by planes on the Caribbean Division of Pan American Airways, adding San Pedro de Macoria as a port of call during 1932 to the one previously made at Santo Domingo. The tri-weekly service operated by a private company during 1931 between Santo Domingo City and Santiago de los Caballeros was discontinued during 1932.

Ecuador was linked with neighboring countries through the regular service of Pan American-Grace Airways on the west coast of South America, 63,648 miles having been flown in the country during 1931 with 380 passengers and 2,000 pounds of mail. Since "Panagra" used amphibians, it was not important that Ecuador had no first class airports, although there were landing fields at Quito, Guayaquil, Latacunga, Manta, Salinas, and Cuenca. Pilots from other countries were warned against planning flights without first learning from the government about landing field conditions. The Ecuadorian Aviation Corps had six officers and 25 enlisted men in 1932. The first two planes of a substantial order for Curtiss-Wright Osprey pursuit and attack planes were delivered in Ecuador in July. The Aviation Corps had no other aircraft equipment since the destruction of two old model planes within the year.

El Salvador through its principal city, San Salvador, was served as a regular stop on the Central American division of Pan American Airways. The only privately owned airplane in the country was in the hands of the Salvadoran Aero Club, a school with six students under instruction, one of whom was graduated during 1932. The El Salvador air force had three Waco biplanes in service.

Guatemala continued to be served by its own national air line, the Compañía Nacional de Aviación, which flew 127,377 miles with 2,716 passengers, 35,552 pounds of mail, and 38,288 pounds of express during the year ended June 30, 1932. Its lines all extended into the interior of the country, saving weeks of travel by flights of an hour or two. The company's equipment consisted of a Fleet (Kinner) biplane, Kreutzer (3 Kinnners) monoplane, Ogden Osprey (3 Menascos); and one Hodkinson (3 Curtiss Challengers). The Guatemalan Air Corps was equipped with ten planes, including two Waco biplanes. Five private fliers held licenses, but there was only one privately owned plane in the country.

Haiti's aviation activities were confined to the operations of Pan American Airways, which made tri-weekly stops at Port au Prince, and the United States Marine Corps. The landing field at Port au Prince was jointly used by the commercial and military services. Military fields were

located at Cape Haitien, Gonaives and Port de Paix on the Haitian mainland and at Jeremie and Hinche on the island of Gonave.

Honduras was served by two Honduran aviation companies which operated service from Tela along the north coast of the country and from Tela across Honduras to a connection with Pan American Airways at San Lorenzo. Both companies also maintained air taxi services.

Mexico's oldest operating air line, Compañia Mexicana de Aviación, S.A., a subsidiary of Pan American Airways, Inc., enjoyed considerably increased passenger and express traffic during 1932, carrying 7,602 passengers and 56,598 kilos of express during the first nine months of the year as compared with 5,462 passengers and 40,735 kilos of express during the same period in 1931. Air mail poundage, however, dropped sharply. Inauguration of service by the new American-owned Mexican air line, Aerovias Centrales, S.A., greatly expanding services throughout all Mexico and providing direct service to the western part of the United States, already has been described. Opening of this service followed the discontinuance of operations by the Corporación Aeronautica de Transportes, S.A., in February, 1932. The Mexican Ministry of Communications and Public Works also had issued experimental permits for air line services within the boundaries of Mexico to Hans Mattes, Juan R. Platt, Francisco Sarabia, Mack R. Ayres, Roberto Fierro, and Jose Mario Najjar Wert. During 1931, 22,454 passengers were flown a total of 2,008,173 miles on scheduled air lines in Mexico, while during the first five months of 1932 9,408 passengers were carried and 722,377 miles flown. Twenty-nine planes, 13 of them trimotored, were in operation on Mexican air line routes. Each regularly established company received a cash subsidy of 160,000 pesos a year. Nearly 200,000 miles also were flown in aerial service operations during 1931, and more than 100 airplanes were licensed in the country by private owners. The Mexican Government was very anxious to encourage air tourists, and aimed to make their entry into the country free from red tape. Military aviation developments in Mexico during 1932 were marked by the formation of a second aerial regiment, composed of 31 Vought Corsairs manufactured in the Mexican Government Aviation Factory under permission, designs and patents of the American company. The first regiment was composed of 10 Vought Corsairs, 11 Douglas pursuit planes, and 10 Bristol fighters of 1920 model.

Nicaragua continued to enjoy the regular service of Pan American Airways on its Central American Division, operating in 1932 on the same schedule maintained during the previous year.

Panama represented the neck of the hour-glass through which air lines from North and South America converged on their routes to all parts of the Western Hemisphere. The Caribbean Division of Pan American Airways, with planes from Miami, Barranquilla, and Trinidad, min-

gled with planes from Brownsville and Mexico City, operating on the Central American Division of Pan American, and with flying boats from Chile and the west coast of South America operated by Pan American-Grace. Panama also was linked with Medellin, Colombia, through Pan American's new "UMCA" subsidiary. Another American-owned company, Isthmian Airways, operated a passenger service between Colon and Balboa, 47 miles, with Hornet-powered Hamilton metal planes. Three schedules were operated daily from the Atlantic to the Pacific side of the Panama Canal and return. The Panama Government also operated mail and pas-



LUXURY ON AMERICAN AIR LINERS

Looking through the rear hatchway into the smoking lounge of Pan American Airways' giant Sikorsky "Clipper" transports.

senger service from Panama City to interior towns of the Republic. Large fleets of patrol boats and military planes were familiar sights in the Canal Zone as a result of the concentration there of both United States Navy and Army aircraft units for the protection of the canal.

Paraguay was without air line service to neighboring countries since the cessation of operation by the French-controlled line, Aeroposta Argentina, S.A., on April 17, 1931. The only aircraft in the country, therefore, were military airplanes, numbering from 12 to 15 of French and Italian manufacture, in possession of the Paraguayan Government Air Force.

Peru was served by Pan American Grace-Airways, whose headquarters were located in Lima; the Faucett Aviation Company, another American-

owned operation; and the *Linea Aerea Nacional* (National Air Line). Over Peruvian territory alone, Pan American-Grace's planes, according to official figures of the Peruvian Inspector-General of Aeronautics, flew 324,188 miles in 496 flights in 1931 and 201,348 miles in 405 flights in the first nine months of 1932, carrying 3,253 passengers in 1931 and 3,681 passengers in the first nine months of 1932. The Faucett Aviation Corporation, a Peruvian corporation with 51 per cent. of its stock held by North American Aviation, Inc., employed American pilots exclusively in its operation of three Wasp-powered Stinson Cabin planes and a Wasp-powered Travel Air. The Faucett company flew 213,375 miles with 2,516 passengers in 1931, and 167,183 miles with 2,536 passengers in the first nine months of 1932. Throughout the year, the company maintained a twice-weekly service from Lima to Piura and Tulara, and weekly from Lima to Arequipa. By the end of the year, the company was preparing to fly a weekly schedule to the remote cities of Cajamarca and Yungay, previously inaccessible except by muleback. On October 1, 1932, both "Panagra" and Faucett had their air mail contracts restored. They had been cancelled June 19, 1931, when the Peruvian Government decided to operate the routes with Army planes. Because of a threatening international situation, the Army planes were called back into purely military service late in 1932. The National Air Line continued services on its two divisions, mountain and coast, with planes and pilots of the Navy and Army air units until the international situation caused a completed cessation of schedules. The *Compagnie Générale Aéropostale* (French) used planes of the Peruvian National Air Lines to carry mail, printed matter and samples south from Lima to Tacna, but the calling of all Peruvian planes into military service left the French line without equipment. Following the suppression of the revolution in Trujillo in June, 1932, the President of Peru appointed a committee of citizens to conduct a popular subscription for funds to complete some local barracks and for the purchase of aircraft. The outbreak of trouble on the Colombian border in early September and the personal donation of \$100,000 by a Peruvian millionaire gave impetus to the collection. By the end of November, \$275,000 worth of American-made aircraft and spare equipment had been purchased by the citizens committee.

Trinidad in the British West Indies continued to be an overnight stop on the Miami-South American route of Pan American Airways, the only air line servicing the island, and was the terminus for the Trinidad-Venezuela run. The only other aviation activity in the island consisted of a single privately owned airplane.

Uruguay's only complete air transport service—combining passengers, mail and express—was provided by the American companies: Pan American-Grace Airways, which maintained five Fords, four Fairchild, two Lockheeds and a Curtiss Falcon in the country; and Pan American Air-

ways, which used six giant Commodore flying boats and five Sikorsky amphibians. It was at Montevideo that "Panagra" planes from the west coast and "Panam" planes from the east coast met to complete the circuit of South America. The French company, Compagnie Générale Aéro-postale, did not carry passengers, but used two French planes to maintain a schedule leaving Montevideo each Saturday night with mail for Europe, flown to Brazil, then shipped by fast boat to Africa, and finally flown by plane to Paris. During 1931, 570 kilograms of mail were carried by Aéro-postale as compared with 363 kilograms during the first nine months of



CUSHIONS IN THE SKY

One of the central cabins in Pan American Airways' giant transports, "American Clipper," "Caribbean Clipper" and "Southern Clipper."

1932. The company suffered a serious accident when one of its planes was forced down near the Uruguayan frontier with the loss of two lives, although the mail was saved. The Uruguayan War Department purchased seven airplanes during 1932, all of them French Potez Lorraine models. The military service also suffered an accident during the year when a training plane crashed with two Uruguayan Army officers who were killed. Both Pan American-Grace and Pan American Airways maintained perfect records with no accidents in the country.

Venezuela authorized a new air service operated with Army planes and equipment, known as Linea Aviacion Comerciales Venezolanos, in September, 1932, to carry passengers and mail between Maracay and Ciudad

Bolivar, via Calabozza and San Fernando de Apure. Two other services were proposed: one from Maracay to Maracaibo via Chichiriviche and Coro, and the other from Maracay to Barinos via Carcarigua and Barquisimeto. The first line, which was in operation late in 1932, paralleled that operated by the French company, Aéropostale, which carried 1,719 passengers for 6,025,000 kilos of mail a total distance of 168,130 miles in 1931. Pan American Airways continued its service from Maracaibo to Port-of-Spain, Trinidad, B.W.I., via Coro, La Guaira and Maturin, all in Venezuela. Pan American carried 1,325 passengers in Venezuela during 1931, official figures showed. The only privately-owned airplane in the country was used by the Standard Oil Company solely for mapping purposes. Venezuela maintained an Army flying school at Maracay to train pilots for its air force, which received the first of a shipment of a squadron of Curtiss-Wright Osprey attack-pursuit planes late in 1932. The remainder of the order was to be delivered in 1933.

Attention is called to the Aircraft and Engine Export Tables, showing complete exports of aeronautical equipment from the United States to foreign countries during 1932. These will be found in Part IV of this volume, "Flying Facts and Figures."

As a practical example of the value of the vast network of air lines throughout the Western Hemisphere, much of the material reported in the chapter was received from American Trade Commissioners and Consular Officials who prepared special reports for "The Aircraft Year Book for 1933" and sped them to New York by air mail. The reports from as far south as Santiago, Chile, and Montevideo, Uruguay—both of them farther from New York than Moscow—were received in little more than a week from the dates they were written. The result is the presentation of up-to-the-minute information on every country reviewed.

CHAPTER XVII

WORLD AVIATION IN 1932

World Air Routes Exceed 196,000 Miles—Air Lines Under Many Flags Show Progress In Review Of Year In Europe, Asia, Africa And Australia—Military Planes See Action

WITH international affairs occupying a greater share of the world's attention than at any previous time in history, air transport—which knew none of the old economic and political boundaries—was making rapid progress in many parts of the world at the opening of 1933.

In a previous chapter, we have seen the progress made in building a vast system of international air lines in the Western Hemisphere, and we can expect this development to be world wide. The total airway route mileage of all scheduled air lines in the world increased during 1932 from 190,000 miles at the opening of the year to 196,000 miles. The total route mileage of airways operated by scheduled services dropped in Australia and Canada, and showed increases elsewhere.

Routes flown under the flags of all European nations combined totaled 85,000 miles in 1932, of which 58,000 miles were located within the continental limits of Europe and the remainder comprised the colonial and empire routes of the several powers. Under the American flag, more than 48,500 airway miles were in operation by scheduled air lines, of which 28,500 miles were located within the continental limits of the United States. Asiatic countries had a total of 26,000 miles of airway routes in operation under their banners, although 46,000 miles of routes were being utilized within the continent. The additional airway mileage in Asia was accounted for by the fact that its great expanses were being hurdled by the relatively infrequent services of British, Dutch, French and German routes to India and the Far East.

While there were 40,000 miles of routes in Latin America alone, only 23,000 miles of these airway routes were being operated under the national flags of Latin American countries. Activity in each of these countries already has been described in the preceding chapter, "Aviation in the Western Hemisphere." Canada had 5,000 airway miles of routes in operation

under her flag, all located within her boundaries. The 6,000 miles of routes carrying the Australian flag, likewise, were confined to the Australian continent. While only 2,500 miles of airways were operated by lines flying the flags of African states, 12,500 miles of routes (principally European) were in operation on the Dark Continent.

Miles of airways, however, do not provide a complete guide for the comparison of the air transport networks of the various countries and continents. Some of the routes, particularly those on colonial lines which often accounted for the longest mileage, were operated very infrequently.

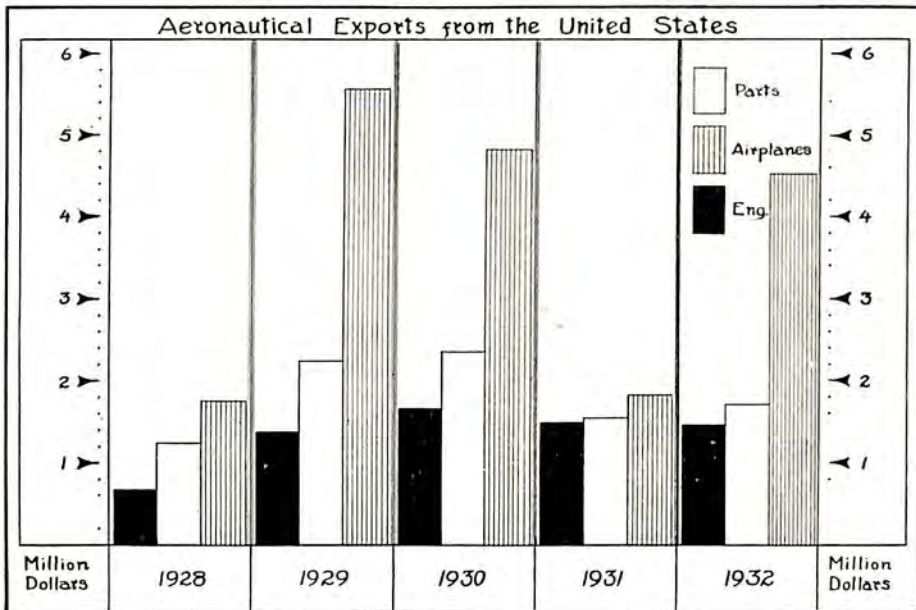

The real guide to comparison, if there can be any just measuring stick, is the total mileage flown by each nation in all classes of scheduled air transport service. Every effort has been made in the following accounts of progress achieved during the year in each country to provide enough statistical information to make comparisons easy, without burdening the reader too much with statistical data.

While air line development claimed first attention, there was considerable progress recorded during the year in technical developments within the manufacturing field, although production in most countries was far below normal levels because of depressed economic conditions. The new stratosphere planes in France and Germany, and new transports in several other countries, were particularly interesting features of the year's advances.

Cash subsidies and other grants from national and city governments

continued to play an important part in the aviation activities of most European and Asiatic countries. Decreases in the year's activity often could be accounted for through a study of the subsidies paid by the government for several years back. While several countries increased their appropriations for aviation, particularly military aeronautics, most nations reduced their total expenditures for the year. However, the major powers abroad made certain that their aircraft manufacturing facilities were held intact by supplying sufficient contracts for military planes to keep factories busy during a naturally laggard period. Military planes saw actual combat service on several fronts during the year, although the world generally was at peace.

As was pointed out in an earlier chapter, France, Italy and Great Britain were conceded to have larger military air establishments than that of the United States, viewed from the standpoint of number of planes in service and total air personnel on active duty. With this single exception, the United States ranked first in every other phase of aeronautic development, so far as its air transport, private flying, aerial service, and manufacturing activities were concerned.

It should be interesting to get a glimpse of aviation activity in all parts of Europe, Asia, Africa and Australia, just as the earlier chapter provided brief reviews for every country in the Western Hemisphere. The information contained in these reviews is more complete and up-to-the-minute than any we have been able to present in past volumes, largely because of the generous cooperation of foreign air officials, executives of transport and manufacturing companies abroad, and scores of others who contributed to the development of reports which were prepared especially for "The Aircraft Year Book For 1933" by American Trade Commissioners and Consular Officials throughout the world. Each country is listed in alphabetical order to facilitate future reference.

Australia

Three subsidized air lines in Australia, operating a total of 5,479 miles of routes, continued to provide service during 1932 under contracts with the Commonwealth Government, which provide that such space as may be required for mails be reserved on each trip, the letters being surcharged 3d. per half ounce. The Queensland and Northern Territories Aerial Services, Ltd., provided weekly service between Brisbane-Camooweal and Brisbane-Normantown, totaling 1,484 miles of routes. Western Australian Airways, Ltd., was operating weekly services from Perth to Derby, Western Australia, 1,467 miles; Derby to Wyndham, Western Australia, 600 miles; and Perth, Western Australia, to Adelaide, South Australia, 1,453 miles. The Larkin Aircraft Supply Company operated between Camooweal, Queensland, and Daly Waters, North Australia, extending its line to

Birdum during the December to March "wet" season when surface transport is impracticable.

New England Airways, the principal non-subsidized company, changed its semi-weekly service to a daily schedule on September 1, 1932, between Sydney, Lismore and Brisbane, 500 miles. L. McK. Johnson also operated a bi-weekly service between Launceston, Tasmania, and Flinders Island.



The Commonwealth Government still had under consideration during 1932 the establishment of an England-Australia air mail service.

Six associated Australian aero clubs, located at Sydney, Melbourne, Brisbane, Adelaide, Perth and Launceston, were operating during the year, receiving a £20 bonus from the Commonwealth Government for each student who qualified for a private pilot's license in addition to the loan of light aeroplanes and engines, accommodation in government hangars, and a cash subsidy for maintenance. Two other organizations, the Goulburn, New South Wales, Aero Club and the Geelong, Victoria, Flying

School received a cash bonus of £40 for each graduate, providing their own aeroplanes and hangar accommodations. The Defence Department also provided aeroplanes for the Central Queensland Aero Club and Bendigo Aero Club, but no cash subsidies. By the end of June, 1932, 854 pupils had qualified for private pilot's licenses, and many graduates completed advance training courses for commercial licenses.

Australia had 58 government aerodromes, 94 public aerodromes, and 124 emergency landing fields throughout the country on June 30, 1932, when all statistics for the previous year are compiled. There were 11 registered aircraft owners, 189 registered aircraft, 363 private licensed pilots, 183 commercial licensed pilots, 289 licensed ground engineers, and 29,829 pounds of mail carried, during the year ending on that date. This represented about a 10 per cent. decrease from the previous year's figures in almost every department of activity. During 1931-32 fiscal year, six persons were killed and 17 injured in aircraft accidents.

The Commonwealth Government made few purchases of aeroplanes during 1931-32. The General Aircraft Company, Ltd., of Sydney manufactured five three-place land biplanes. The de Havilland Company continued operation of its assembly plant at Sydney using British parts and engines, and, although not as active as in previous years, the Larkin Aircraft Supply Company, Ltd., of Melbourne offered its Moth aeroplanes for order.

Austria

Operating with a higher degree of regularity than in any previous year, the network of national and international air lines radiating from the capital, Vienna, provided Austria with service to all parts of Europe during 1932. The Oesterreichische Phoenix Flugzeugwerke at Woellersdorf, Lower Austria, aircraft manufacturers, went into the hands of the receiver during the year. This company and another which continued in operation, Theodor Hopfner in Vienna, produced 10 airplanes during 1931. Because Austria had no military aviation, in compliance with the peace treaty of Saint Germain, production was limited to small sport planes for private use.

Notwithstanding the relatively small purchasing capacity of the Austrian people, the mountainous character of the country and other obstacles to private flying, 40 airplanes were privately owned in the country in September, 1932. This did not include numerous gliders (Segelflugzeuge) owned by associations, individuals or groups of students.

The Austrian Air Traffic Company (Oesterreichische Luftverkehrs, A. G.), aided in 1932 by a government subsidy of \$216,000 as compared with a subsidy of \$285,560 in 1931, reported a considerable reduction in traffic over its four principal routes as the result of depressed economic

conditions. Although passenger tariffs were reduced about 20 per cent. in the Spring of 1932, the company did not expect its total figures for the year to equal those of 1931 when 411,952 miles were flown with 9,192 passengers, 38,840 pounds of mail, and 234,358 pounds of freight. Except for an increase of 19,000 pounds in freight traffic, the 1931 figures also represented a decrease from 1930 levels. Services wholly operated by the Austrian Air Traffic Company were: Vienna-Graz-Klagenfurt, daily, May 1 to August 31; Vienna-Klagenfurt-Venice, thrice weekly, May 1 to August 31; Salzburg-Innsbruck, daily, June 1 to September 30; Vienna-Graz-Klagenfurt-Venice, thrice weekly, March 1 to April 30 and September 1 to October 31. The company also cooperated with German, Czechoslovakian, French, Italian, and Yugoslavian air lines to provide joint services to neighboring countries. In addition, Italian, Hungarian, French, Swiss, and Polish air lines operated routes from their respective countries into or through Austria. A glance at the accompanying map of air line services in Europe will show more clearly the extent of this intermingling of lines under various flags. The Austrian Air Traffic Company used Junkers planes almost exclusively, owning six Junkers F13 single-engined transports, two Junkers G24 tri-motors; and one Junkers G31 tri-motored transport.

Belgium

Despite the difficulty of building up an aeronautics industry in a country as small as Belgium, considerable progress was being made through the operation of its ten aircraft manufacturing plants, its government subsidized air transport line, and some private or tourist flying.

During the first ninth months of 1932, the ten manufacturing plants produced 50 planes with a total value of 21,147,000 francs; as compared with 78 planes with a total value of 23,198,500 in all of 1931. The chief manufacturers in operation in 1932 were: the Belgian Aeronautic Construction Company ("SABCA") at Brussels; Société d'Enterprises Générales d'Aéronautique ("Sega") at Gosselies; Stampe and Vertongen at St. Hubert; Dassy at Brussels; Guldentops at Brussels; Wielemans at Brussels; Avions Bulté and Company at Wolverthem; G. Renard at Brussels; and Avions et Moteurs Renard at Brussels. "SABCA," capitalized at 30,000,000 Belgian francs, was by far the most important, although its production was greatly reduced toward the close of 1932. Aircraft engines were produced solely by Avions et Moteurs Renard late in 1932 after "SABCA" stopped its engine production in June. During the first nine months of 1932, 25 engines valued at 1,875,000 francs were produced as compared with 40 valued at 2,400,000 francs in all of 1931.

The Société Anonyme Belge d'Exploitation de la Navigation Aérienne ("SABENA"), subsidized by the Belgian Government to the extent of

EUROPEAN AIR LINES

Prepared for
 "The Aircraft Year Book for 1933"

by
 Aeronautics Trade Division
 Bureau of Foreign and Domestic Commerce

KEY

- | | |
|----------------|---------------------------------|
| 1 Austrian | 17 Austrian-German |
| 2 Belgian | 18 Austrian-Czechoslovak-German |
| 3 Czechoslovak | 19 Austrian-Italian |
| 4 Danish | 20 Austrian-Yugoslav |
| 5 Finnish | 21 Danish-German |
| 6 French | 22 Danish-French-German |
| 7 German | 23 Dutch-German |
| 8 British | 24 French-German |
| 9 Hungarian | 25 Italian-German-Austrian |
| 10 Italian | 26 Russian-German |
| 11 Dutch | 27 Swiss-German |
| 12 Polish | 28 Dutch-Swedish |
| 13 Rumanian | 29 Finnish-Swedish |
| 14 Spanish | 30 Italian-German |
| 14 Swiss | 31 Swiss-French |
| 16 Yugoslav | 32 Swiss-Czechoslovak |
| | 33 Greek |

Note: Paris-Brindisi Section of British Route by Rail.

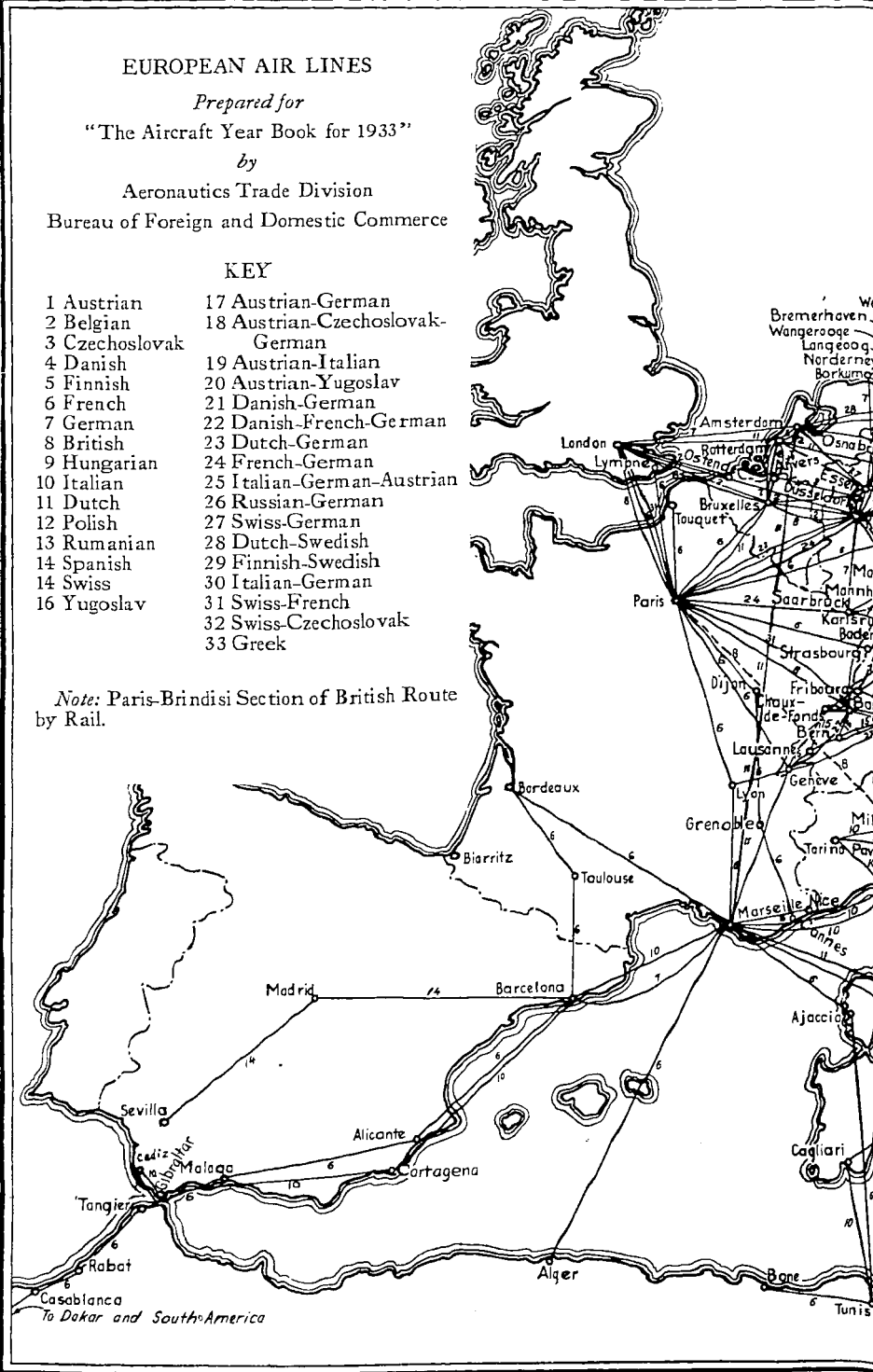

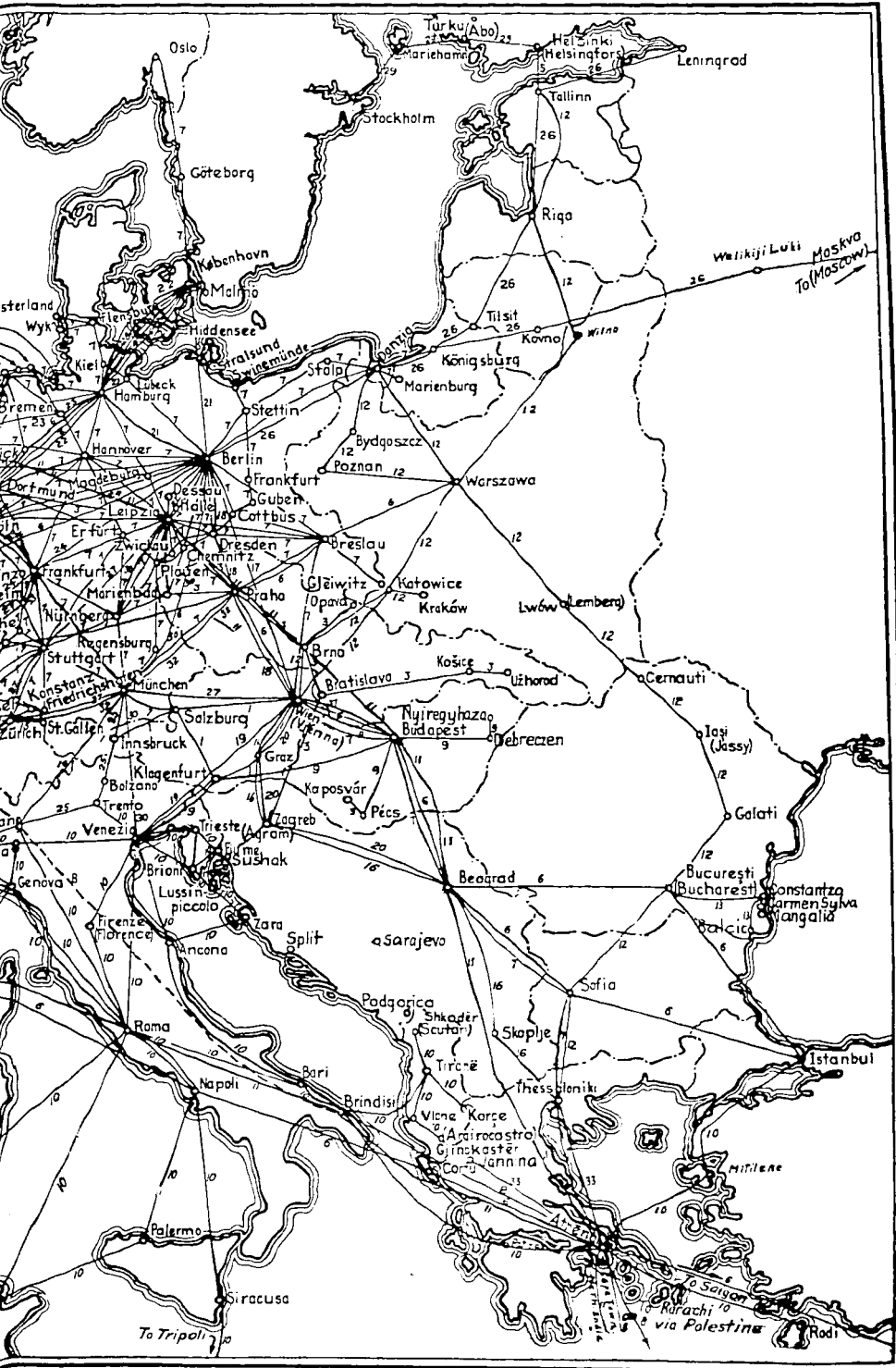

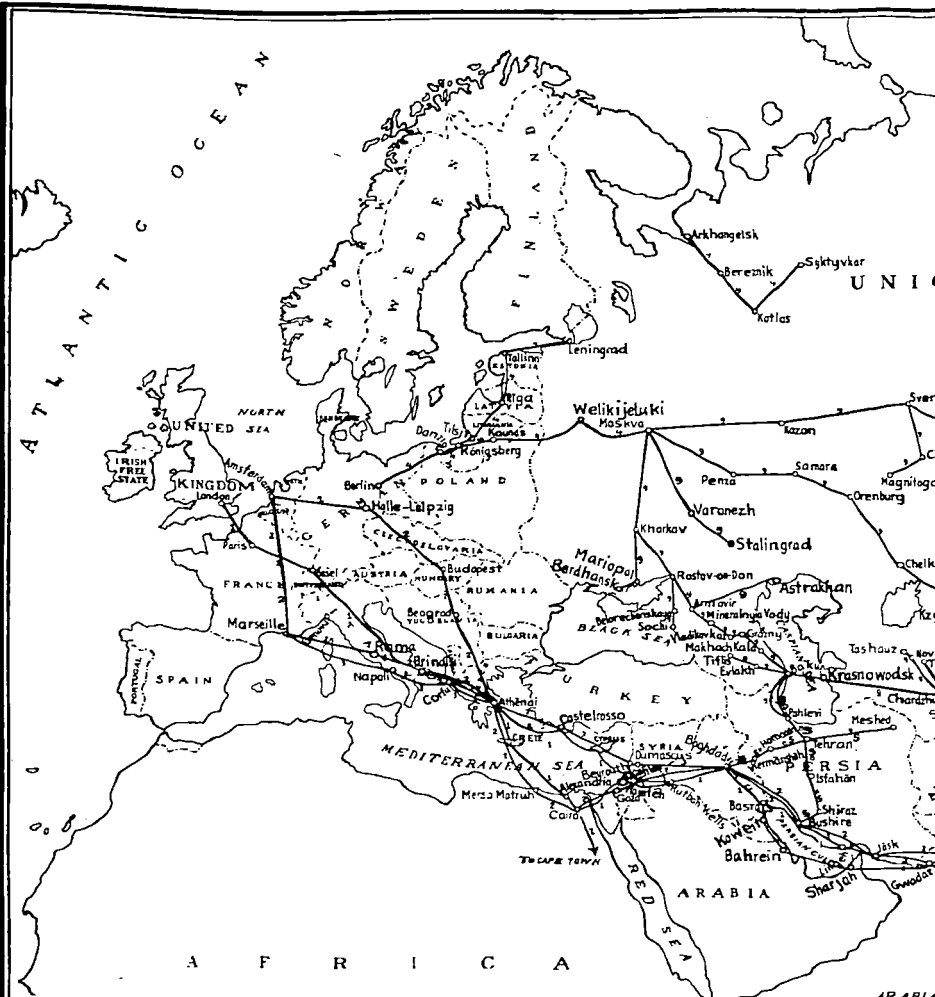

AIR LINES IN ASIA

Prepared for

"The Aircraft Year Book for 1933"

by

Aeronautics Trade Division

Bureau of Foreign and Domestic Commerce

KEY

- | | |
|------------------|---------------------------|
| 1 British | 7 Netherlands East Indian |
| 2 Dutch | 8 Persian |
| 3 French | 9 Russian |
| 4 German-Russian | 10 Siamese |
| 5 Chinese | 11 Philippine |
| 6 Japanese | 12 Indian |

S Suspended

Note: Dutch Route via North in Summer, South in Winter; Paris-Brindisi and Alexandria-Cairo Section of British Route Served by Rail.

UNION OF SOVIET SOCIALIST REPUBLICS

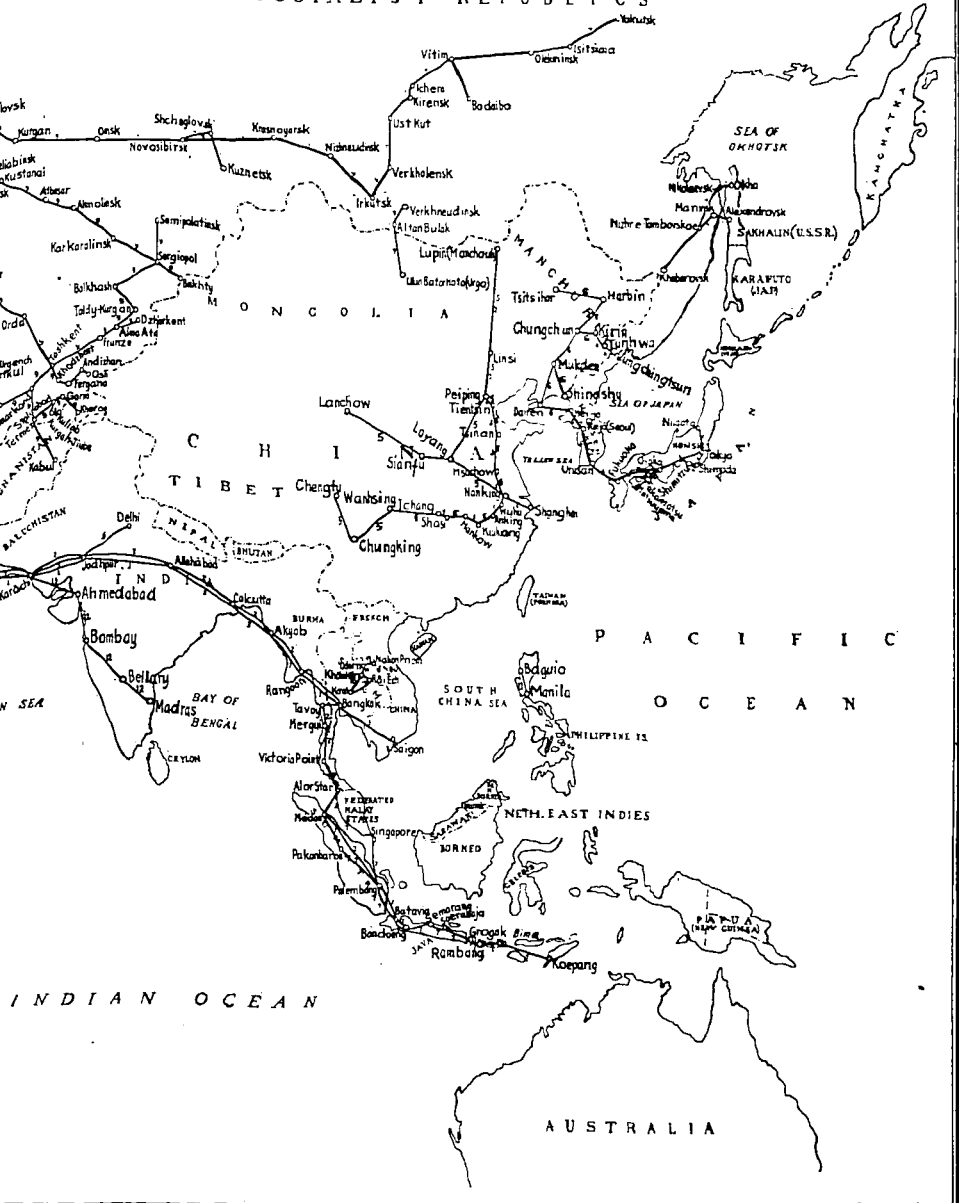

17,334,000 francs in 1932, operated 32 airplanes on its European services and 16 planes on its African services in the Belgian Congo, most of them Fokkers or Handley Pages. During 1932, the company operated seven



KING INSPECTS THE WASP

King Albert of Belgium with Director Plesman of K.L.M. inspecting an American-made Wasp engine on a Fokker transport.

routes: London-Brussels-Cologne-Dusseldorf; Brussels-Dusseldorf-Essen-Dortmund-Berlin; Brussels-Essen-Hamburg-Copenhagen-Malmoe; Antwerp-Cologne-Dusseldorf-Essen; Le Zoute-Ostend-London; Brussels-Rotterdam-Amsterdam; and Brussels-Antwerp. During the winter only the first

two services named were operated, making a total of 1,960 kilometers flown daily in winter and 5,550 kilometers in summer. In addition to the European service, "SABENA" operated two routes in the Belgian Congo: Boma-Léopoldville-Coquilhatville-Stanleyville and Léopoldville-Port Francqui. Night mail service operated by the company during 1931 between Brussels and London was discontinued October 3, 1931, and not resumed during 1932.

During the first eight months of 1932, "SABENA" flew 843,895 kilometers in its European services with 6,296 passengers, 22,687 kilograms of mail, and 171,417 kilograms of express; as compared with 1,141,897 kilometers flown with 7,721 passengers, 54,611 kilograms of mail, and 327,975 kilograms of express. In its African services, 97,117 kilometers were flown with 410 passengers, 18,195 kilograms of mail and 4,782 kilograms of express during the first seven months of 1932; as compared with 241,989 kilometers flown with 1,241 passengers, 31,440 kilograms of mail, and 17,784 kilograms of express in all of 1931. The company suffered no accidents during 1932, and had but one accident in 1931 when the crew of a night mail plane was killed.

In addition to the services operated by "SABENA," British, French, Dutch and German lines operated through Belgium during 1932, Brussels being the port of call on each service. These services will be described under the activities of the country in which each of those several air lines are nationals. Belgium had seven firms active during the year as aerial service operators, doing taxi and photographic work. Sixty-one touring airplanes were privately owned in the country, piling up an annual total of approximately 160,000 kilometers. Tourist (private) licenses have been issued to 313 pilots.

Bulgaria

Government aviation activities in Bulgaria during 1932 were limited to the training of pilots in small two-place planes, since its "State Aviation" program had not been extended to transportation of mail or passengers, chiefly because of the lack of funds. The Direction of Aeronautics at Sofia owned and supervised the operation of 43 land planes and two seaplanes, 30 of which had been built in the State Airplane Factory (Darjavna Aeroplanna Rabotilnitza) at Sofia. Under the terms of the treaty of Neuilly, there is no military aviation in Bulgaria.

During the first ten months of 1932, two planes were produced in the State Airplane Factory—the first tri-motored passenger plane to be produced in the country and a training plane. While Bulgaria had no air lines of its own, 17 airplanes were in service during 1932 to maintain the routes flown by German and French air lines through Bulgaria to their terminus at Istanbul, Turkey.

With extensive reorganization under way in both the National Government and South China air forces at the close of 1932, all aviation in China continued to be under the control of the military authorities. Prospects for the development of private flying and for the extension of commercial air lines were considered favorable, although military operations continued to occupy the center of attention.

While some aircraft were produced in several Chinese factories during 1932, most of the equipment was purchased from foreign countries. The National Government favored American, Italian and, to a lesser extent, British aircraft. North China made all of its airplane purchases in the United States. South China purchased both American and British equipment. Chungking, in Szechuen province, bought its planes in France, although efforts to deliver five Potez planes by air from Hanoi had been unsuccessful up until late in the year, with the loss of two ships enroute.

The importance of China as a market for American aircraft and equipment can be seen from the tables of planes, engines and accessories exported during 1932, which are printed in Part IV of this volume, "Flying Facts and Figures." There was little manufacturing activity during the year in the principal factories at Canton, Amoy and Shanghai.

Two Wasp-powered Sikorskys were used extensively by officers of the National Government. Two Wasp-powered tri-motored Fords were put into the service of Young Marshal, whose air forces were greatly reduced in the occupation of Manchuria and were undergoing a reorganization at the close of the year.

Keystone-Loening amphibians, powered with Wright Cyclone and Pratt and Whitney Hornet engines, were employed on a daily scheduled service for passengers and mail between Shanghai and Hankow, 500 miles, by the Chinese National Aviation Corporation, a joint Sino Curtiss-Wright enterprise with American pilots and Chinese co-pilots. The route was extended during 1932 from Hankow to Wanhsing, Chungking and Chengtu. Another route from Nanking to Peiping, inaugurated during 1931 with mail, was suspended during 1932. The Chinese National Aviation Corporation maintained 99 per cent. of its 311,460 scheduled miles during the first nine months of 1932, with 2,528 passengers, 4,704 pounds of express, and 78,213 pounds of mail.

The Eurasian Aviation Corporation, organized by the Chinese Ministry of Communications and the Deutsche Luft Hansa to link Shanghai with Berlin through an air-rail hook-up using German planes and pilots for the major share of the distance, reported 78,430 scheduled kilometers and 31,198 kilometers of special trips flown with 263 passengers, 787.5 kilograms of mail, and 4,394.2 kilograms of express carried during the period in which the service was operated—May until August.

In Manchuria, aircraft were used extensively during the year by Japan

in the occupation of the province. On September 27, 1932, the Manchoukuo Air Traffic Company, Ltd., was organized at Changchun, China, as a joint stock company with a capital of approximately \$800,000, consisting of 7,700 shares to be divided between the government, the South Manchurian Railway, the Sumitomo Company, and a small amount for public sale. The company was to receive subsidies from the Japanese Government to establish two regular services: Darien-Mukden and New Wiju-Harbin.

The South China and Chungking air forces were virtually independent national air units. Some of the other provincial governments maintained a small number of planes. Hangchow, Canton and Nanking in Kwanksi province and Changsha were the principal centers for military aviation training activities at the close of 1932. Changsha was independently financed but under the control of the central government.

A plan for the development of aviation and the training of Chinese flying students was approved in principle by T. V. Soong, Minister of Finance of the National Government, and funds were deposited during 1932 for the purchase of equipment and payment of salaries of foreign advisers and instructor personnel for an aviation training school in China. An American aviation mission headed by John H. Jouett and fourteen American pilots arrived in China in the early fall as the first step in the accomplishment of the plan. The base of the National Government school was at Hangchow, 110 miles southwest of Shanghai.

The Canton Aviation Bureau was headed by General Huang-yu who succeeded General Chang-Wei-chang. General Chang, although Cantonese, was chief of the Nanking Aviation Bureau at one time. At the close of 1932, he was operating independently, some of the former pilots of the Canton bureau being with him. The Canton Bureau added to its equipment, consisting of about 50 airplanes, by purchasing five American Douglas aircraft and several British Armstrong Whitworth 16's. The Canton Aviation Bureau's factory turned out several aircraft of the two-place light bombardment and observation type using engines and other parts imported from the United States. A single-seater pursuit plane was manufactured at the factory for the first time. It was projected during the latter part of 1932 to increase the equipment of the Canton Bureau to 400 aircraft and train adequate personnel, both pilots and observers, to man that number of planes. The military aviation school at Canton was expanded during 1932 so that late in the year there were more than 130 students under instruction.

Six American training planes were delivered early in 1932 to the Yunnan Aviation Bureau at Yunnanfu. The Bureau had previously standardized on French equipment.

Planes of the Canton Aviation Bureau saw action in two localities dur-

ing 1932, in February at Shanghai and during the summer in the anti-communist drive on the Kwangtung-Kiangsi border.

Czechoslovakia

Czechoslovakia, unlike some countries which cut their subsidies for aviation purposes, increased its aid during 1932 and experienced a general increase in traffic on its air lines.

Ten million crowns, representing an increase of 1,000,000 crowns, was appropriated by the Government for the 1932 operations of the Czechoslovak Air Traffic Company, a private enterprise controlled by the Skoda works. The company provided international air service to Germany, the Netherlands, Austria and Switzerland. It operated planes on its Prague-Halle-Leipzig-Essen-Muehlheim-Rotterdam-Amsterdam route six times a week in both directions from April 1 to October 15, and on its Prague-Munich-Zurich-Basel route three times each week, in both directions, from April 1 to September 30. Year round service was maintained between Prague-Vienna, Prague-Dresden-Berlin and Marienbad-Halle-Leipzig. In 1932, the Czechoslovak Air Traffic Company flew 500,291 kilometers with 4,313 passengers, 19,101 kilograms of mail and 146,000 kilograms of freight, an increase in every traffic branch over 1931. Thirteen planes were used to maintain these services, which showed a performance of from 87 to 94 per cent. of the total scheduled mileage. The company had 24 forced landings during the year, but no accidents.

The State Air Lines (*Statni Aerolinie*), owned and operated by the Government under the jurisdiction of the Ministry of Public Works, provided service on several routes during the summer months: Brno-Bratislava-Kosice-Uzhorod, 718 kilometers; Bratislava-Zagreb, 320 kilometers; and Prague-Marienbad-Carlsbad. The line considered new extensions from Uzhorod via Klausenburg to Bucharest, and from Zagreb to a point on the Adriatic, probably Susak. The State Air Lines flew 570,754 kilometers with 8,000 passengers, 5,254 kilograms of mail and 231,274 kilograms of freight. Twenty-eight planes were used in the service, which was maintained with a regularity of 96.7 per cent., and with no forced landings and no fatal accidents during the year.

The *Compagnie Internationale de Navigation Aérienne* ("CIDNA"), the French air line, had its subsidy from the Czechoslovakian Government raised during 1932 from 3,500,000 crowns in 1931 to 3,600,000 crowns. The company also received aid from the French Government for the promotion of its services, one of which served Prague. The line extended from Paris to Strasbourg, Prague, Vienna, Budapest, Belgrade, Bucharest and Istanbul, with a branch from Prague to Warsaw. The company employed some Czechoslovakian equipment and flying personnel.

The country had three aeronautical associations with 21 airplanes and 126,000 members. There also were five flying clubs: one at Prague with three airplanes and 703 members; another at Brno, Moravia, with 12 air-

planes and 823 members; a third at Bratislava, Slovakia, with three airplanes and 130 members; a fourth at Pardubice, Bohemia, with two airplanes and 130 members; and the fifth at Plzén, Bohemia, with nine planes and 278 members. Aside from these club-owned planes, there were 88 privately owned aircraft in the country. Virtually all of the planes were of Czechoslovak manufacture because the local industry was protected by high import duties and by important restrictions.

Denmark

Aviation in Denmark was centered in the operations of the Danish Air Transport Company, Ltd. (Det Danske Luftfartselskab A/S), which



COPENHAGEN'S AIR CENTER

Crowds at Kastrup Airport in Copenhagen, Denmark, watch sightseeing planes and air line transports in action.

maintained two routes during 1932: Malmo-Copenhagen-Flensburg and Malmo-Copenhagen-Hamburg. The company's services extended over 1,340 kilometers of day services and 975 kilometers flown at night during the summer season.

Four Fokker FVII (Bristol Jupiter) transports, manned by three pilots and four mechanics and radio operators, were used in the services, which amounted to 209,150 kilometers flown during 1931 with 2,885 passengers, 12,159 kilograms of mail, and 45,979 kilograms of express and baggage. The Danish Government subsidized the line with an annual grant of 250,000 kroner, supplemented by 100,000 kroner from the City of Copenhagen and a contract guaranteeing 625 kilograms of mail on each night flight.

Five operators, using six airplanes, maintained aerial service operations in the country, chiefly for taxi work and sightseeing. No students were under instruction in aviation schools toward the close of 1932, one pilot and one mechanic having been graduated during the year. There was only one privately owned airplane in Denmark and 16 private fliers held licenses. Although little authentic information on military aviation could be obtained, it was reported that more than 60 planes were employed by the Army and Navy air services.

Egypt

Egypt continued to be an important base for Imperial Airways (British) and K.L.M. (Dutch) planes connecting Europe with the Near East, India and various parts of Africa. The Imperial service on the India route was improved during 1932 by four new Handley Page four-engined planes of the Hannibal class, with accommodations for 24 passengers and a crew of four. Regular weekly departures were maintained from Alexandria to Genoa via Athens and a steady increase in all classes of traffic was reported. Fokker tri-motors of K.L.M., carrying six passengers, three in the crew and mail, arrived at Cairo weekly from the Dutch East Indies and flew to Amsterdam via Central Europe.

Government expenditures on the civil airports of Almaza, near Cairo, and Dekeila, Alexandria, aided considerably in expanding private flying. An English-Egyptian company, Airwork, using four Gipsy Moths for taxi service, operated the government-built hangar at Almaza, where full custom and weather reporting facilities were available. Several Egyptians bought private planes during the year as a result of the increased facilities offered.

The Egyptian Air Force continued its operations with Gipsy Moth aeroplanes and its ground organization was extended. The Egyptian Touring Club aided transient fliers by compiling maps for pilots.

Estonia

Private flying was being fostered in Estonia by a national organization which changed its name early in 1932 from Air Defense Association to the Aeronautical Association. Twelve member associations had been organized in provincial towns by the end of October, 1932, and the organization was active in arranging airplane model construction courses for school children, staging a model competition between boys of Finland and Estonia, and providing airport facilities. Four of the ten landing fields in the organization's program were available for use late in 1932. The association's ultimate purpose was to provide means from private sources for national

defense. Two members owned airplanes which were used to train a class of six private pilots, all of whom were licensed in August, 1932.

Estonian military aviation was concentrated in one unit, called the Air Defense (Öhukaitse), equipped with about 50 planes. All of them were light single-engined ships, for use in scouting and light bombing, with the exception of several single-seater pursuit planes.

Although Estonia had had no commercial air lines of its own since 1927, its capital, Tallinn, was linked with the network of European air lines through the service of the Finnish Air Service Company (O/Y Aero), Tallinn-Helsingfors; the German-Russian company ("Deruluft"), Riga-Tallinn-Leningrad; and the Polish company ("Lot"), Tallinn-Riga-Warsaw. The latter service was inaugurated during 1932. All routes were maintained during the summer months with operations suspended in October, except the Tallinn-Helsingfors line which was reopened December 20, when landings on the ice become possible.

During the 1932 flying season, the Finnish and German-Russian companies flew 293,870 kilometers with 2,834 passengers, 37,260 kilograms of baggage and freight, and 7,862 kilograms of mail. No cash subsidies were granted the air lines, but the Estonian Government paid the three foreign lines on air mail contracts granted. There were no fatalities during 1932.

Finland

Finland used 10,000,000 marks out of a total appropriation of 350,000,000 marks for unemployment relief in 1932-33 for the construction of landing fields and other construction recommended by the Ministry of Defense. An additional 2,000,000 marks was appropriated for a landing field at Abo.

The State Government proposed in its recommendations for 1933 appropriations to increase the sum set aside for aviation development by 250,000 marks to 2,250,000 marks annually. The unemployment relief program resulted after the Air Defense League presented a proposal in August, 1932, to the Ministry of Communications and Public Works, requesting the construction of 19 large and 33 small landing fields.

The repeal of prohibition, departure from the gold standard, and depressed economic conditions were variously blamed for a decrease in Finnish air traffic during 1932, amounting to from 20 to 60 per cent. The Finnish Air Service (Aero Osakeyhtiö), the only commercial aviation company in Finland, reported traffic on its Helsingfors-Reval line as an example: 2,069 passengers (20 per cent. less than 1931), 2,235 kilograms of mail (60 per cent. decrease), and 2,051 kilograms freight (34 per cent. decrease). The company also maintained service between Helsingfors and

Stockholm, and participated for four months in the operation of an international night mail service between Stockholm and Copenhagen.

The Osakeyhtiö Sääski, which in 1931 manufactured planes, imported engines and maintained a flying school, suspended activities during 1932. The Ministry of Defense factory at Sveaborg was reported engaged mainly in the repair of flying equipment instead of new production. There were eight military airdromes and one small landing field in Finland. Three of them were for seaplanes, three for land planes, and two adapted for land and seaplanes.

France

The continuation of unfavorable economic conditions throughout the world did not prevent French aviation from pursuing, in 1932, the development of its aircraft manufacturing, commercial air transport, and private flying activities. Although the general activity of the air lines was maintained at former levels, the effects of the depression were shown in the decreased volume of express handled, the smaller number of airplanes purchased by individuals, and the smaller number of all aircraft manufactured.

During 1932 a comprehensive plan for improving the ground equipment in France and its colonies was drawn up by the Ministry of Air. Execution of the plan would involve expenditures of 120 to 160 million dollars, spread over several years as credits for the purpose are voted by Parliament. In 1932 efforts were concentrated on equipment of the principal aviation bases of Le Bourget (Paris), Marignan (Marseilles), Strasbourg, Algiers and Tunis.

No official figures were available on the number of airplanes manufactured in France, but it was estimated that about 600 were produced in 1932, which was 50 or 75 less than in 1931. About one-fourth of the total were civil planes, the remainder for Army or Navy service. France imported almost no aeronautical equipment, because of the well established industry and the numerous government measures taken to encourage it. French exports of aeronautical products were about 100 times as great as imports, amounting to \$6,653,000 in 1931 and \$8,518,280 in 1930.

Among the most interesting developments of the year, from the standpoint of construction, were the stratosphere planes of Farman and Guerschais, with which it is hoped to reach an altitude of more than 60,000 feet; the giant flying boats being built for Aéropostale for South Atlantic air service; and the seaplane under construction by Breguet with a stainless steel hull bottom. The names and addresses of the principal aircraft manufacturers had not changed from the list printed in "The Aircraft Year Book for 1930."

French aviation received a large measure of support from the Government in the nature of direct subsidies. The total air budget, after deduc-

tion of \$8,000,000 in economies voted in August, was \$83,250,000 for the year 1932 (the French fiscal year having been changed to commence January 1), a decrease of about \$3,178,000 from the preceding year. One of the most important items, from the standpoint of commercial aviation, was the appropriation of \$7,160,000 for subsidies to five commercial air lines receiving direct aid from the government. Forty per cent. of this amount was for Aéropostale, operating service to South America. About \$250,000 was appropriated to pay the greater portion of the purchase price and share the operating expense of airplanes bought by individuals, as well as to generally promote private flying.



"SILVER STAR" OF FRANCE

Tri-motored Farman F300, the "Silver Star" used on some of the French lines which radiate from Paris.

France's subsidized air transport lines totaled 23,720 miles in length. In October, 1932, these five companies had 252 planes and 140 pilots in service, somewhat smaller than the figures for 1931. During the first eight months of 1932, the five lines showed an increase of about eight per cent. in the number of passengers carried, and an increase of nine per cent. in the mail ton-kilometers handled compared with the same period in 1931. However, there was a decrease of about 33 per cent. in the volume of express handled. Figures for the first eight months were: 3,510,316 miles flown with 25,381 passengers, 175,083 metric ton-miles of express, and 87,407 metric ton-miles of mail.

Although there was no regular night flying in France during 1932, six airways totaling 1,680 miles in length were lighted and in readiness whenever the occasion for night flying might demand. It should be interesting to get a glimpse of the services and activities of France's five air lines.

Aéropostale (Compagnie Générale Aéropostale) operated weekly service on the route: Toulouse-Barcelona-Tangiers-Casablanca-Dakar-Natal-Buenos Aires-Santiago; and from Marseilles via Balearic Islands to Algiers. Service on the France to Chile route, named first, was operated as a daily schedule as far as Casablanca. Services formerly operated between Paris, Bordeaux and Madrid were not maintained during 1932. The average time for the trip to South America was reduced eight to seven and one-half days, and that of the return trip from nine to eight and one-half days. The company incurred acute financial difficulties early in 1931, and was in the process of judiciary liquidation at the close of 1932 with a view to reorganization.

Air Orient changed its service between France and Indo-China from a bi-weekly to a weekly basis in May, 1932, and reduced from 11 to 8 days the average time required for a flight from Marseilles to Saigon, via Naples, Corfu, Athens, Castelloroso, Beirut, Damascus, Baghdad, Bushire, Jask, Karachi, Jodhpur, Allahabad, Calcutta, Akyab, Rangoon, and Bangkok. Extension of the line to Hanoi was being considered. The service, formerly limited to mail, was made available in 1932 to passengers and express as well. At its inception, the line was operated in conjunction with K.L.M. (Dutch), but since the establishment of the weekly schedule it became an all-French service.

Air Union maintained its principal service between Paris and London, which increased in popularity during 1932. The company also operated services between Paris-Lyons-Ajaccio-Marseilles; Paris-Geneva; Paris-Lyons-Cannes; Lyons-Geneva; Marseilles-Tunis; Tunis-Boue (summer). On demand, the line also transported mail and passengers between Paris and Cherbourg for trans-Atlantic boat connections.

"CIDNA" (Compagnie Internationale de Navigation Aérienne) operated a long line from Paris to Strasbourg, Prague, Budapest, and Istanbul, with connections to Warsaw, Belgrade, Sofia, Salonica and Athens. It received subsidies from France, Czechoslovakia, Roumania, Yugoslavia, and Poland. "CIDNA" also participated with the Air Union and the Swiss Air Company in a pool service between Paris, Basel and Zurich. During 1932 the company inaugurated higher speed planes for the service and on several occasions made the trip between Athens and Paris in one day.

Farman Lines (Société Générale de Transportes Aériens) cooperated with the German, Dutch and Swedish lines in operating services to Germany, the Netherlands and the Scandinavian peninsula, respectively. The lines served were: Paris-Amsterdam-Hamburg-Copenhagen-Malmo; Paris-

Cologne-Berlin; Paris-Saarbrücken-Frankfurt-Berlin (suspended in winter); Paris-Brussels-Antwerp-Rotterdam-Amsterdam. The Paris-Scandinavian service was being maintained for the first time throughout the winter in 1932-33.

The project for a Belgium-France-Congo line, to be extended ultimately to Madagascar, was still held in abeyance, because of the failure of the Ministry of Air to designate the French company to participate and because of reduced appropriations. Star, a non-subsidized service formerly operating between Cannes and Paris, discontinued its activities.

Although no reliable statistics on military and naval aviation were available, France was conceded to have one of the largest military air establishments in the world and often was spoken of as being the first ranking world air power in so far as the number of its planes, amount of its air armament equipment, and size of its pilot personnel was concerned. The planes in its service all were of French manufacture, developed through the aid of heavy government subsidies.

The number of civil airplanes registered in France increased from 1,320 on July 1, 1931, to 1,544 on July 1, 1932. Of the latter number, 994 were owned by 44 companies engaged in air transport, aerial advertising, flying instruction or other commercial operations; 390 belonged to individuals; and 160 to 86 aero clubs. Some of these planes had been registered since 1928, so that the actual number of civil airplanes in operation in France or on French air routes was probably somewhat smaller.

Germany

Germany's principal aviation interests were centered in the operation of its great air transport company, Deutsche Luft Hansa A.G., and two affiliated companies, Deutsche Verkehrsflug A.G. and "Deruluft." Curtailments in the Luft Hansa's service during 1932 affected only the intra-German routes, all services to 28 cities outside Germany being maintained as in 1931.

During the summer of 1932, the Luft Hansa operated 38 scheduled services for passengers, mail and express with its own planes and personnel exclusively. In addition 15 lines were operated jointly on a pool basis with foreign operators, and there were 14 lines across Germany operated by foreign operators exclusively. The Luft Hansa's affiliated company, the Deutsche Verkehrsflug, flew over nine different routes, and the "Deruluft" operated two lines. The Luft Hansa also flew four special mail and freight lines, as well as connecting services between Berlin and Friedrichshafen, carrying passengers, mail and freight to connect with the arrivals and departures of the "Graf Zeppelin" in its South American service. The catapult service from the "Bremen" and "Europa" was continued in 1932,

as well as the connecting services to and from Bremerhaven with the arrival of these ships.

New connections in 1932 enabled a flight from Berlin to Rome to be completed in one day in either direction, the flying time being nine and one-half hours. Karlsbad was connected up in 1932 as a part of the line from Berlin and Central Germany to Marienbad. Traffic schedules were speeded up by shortening the flying time and length of stop-overs on many of the routes. The mail and freight services to the Orient were expedited during the summer of 1932, the route leading from Berlin to Sofia with



NEW PLANE FOR "EUROPA"

Hornet-powered Junkers 46 seaplane being catapulted from liner "Europa" to speed mail to port ahead of ship.

semi-weekly connections to Athens via Salonica, instead of to Istanbul as in 1931. Previously the service was by air and rail for mail and freight only, while in 1932 airplanes were used over the entire route to carry passengers in addition. A study of the accompanying map of air lines in Europe will indicate the extent of the German air lines' operations, not only in Germany, but throughout Europe and Asia. Those lines operated in cooperation with other nationals have been marked with a distinguishing key number.

The Luft Hansa continued its policy of reducing fares in proportion to the decline in the wholesale price index. In addition summer excursion tickets were introduced, on which a 30 per cent. reduction was granted

on the cost of the return ticket, when the going and returning portions of the ticket were purchased at the same time. The Luft Hansa obtained a laid up freight steamer, the "Westfalen," from the North German Lloyd for use as a floating terminal in the middle of the South Atlantic for the proposed South American service. The ship was being conditioned at Bremen at the close of 1932. The "Graf Zeppelin" completed nine round-trips to South America from Germany in 1932, operating on a regular schedule with passengers, mail and express. This operation is described in another chapter devoted entirely to lighter-than-air developments.



NEW GERMAN TRANSPORT

New Walter-powered Dornier DO-K, latest land transport developed by the builders of the DO-X in Germany.

Like other branches of German aviation, air transport in Germany received substantial aid through cash subsidies and grants of the Government. Appropriations for the Luft Hansa's subsidy in 1932-33 (fiscal year ends March 31) totaled 17,362,000 marks as compared with 18,825,000 marks in 1931-32 and 19,000,000 marks in 1930-31. In addition several German state and city governments subsidized the company to aid in maintaining its services. The total subsidies of the German Government for aviation purposes, including private flying and manufacturing, totaled 43,843,200 marks in 1932-33. Statistics on German air line operations of scheduled services in 1931 were: 10,338,446 kilometers flown with 98,167 passengers, 405,932 kilograms of mail, and 2,230,756 kilograms of freight,

baggage and newspapers. The maximum daily distance flown by the three affiliated lines in 1931 was 60,920 kilometers. Two passengers and two airmen were killed in scheduled air traffic during that year.

The three German lines employed 36 large transports, 47 medium-sized planes, and 61 small machines to maintain their services, and employed a total of 1,800 persons, including 250 pilots, radio operators and stewards. In an allied field of operation, there were 10 fairly important firms and 40 smaller concerns engaged in aerial service operations, excluding flying schools. There were 12 aviation schools operated by eight different concerns. It is difficult to learn the number of planes in the hands of private fliers, but it was known that there were not more than 1,150 planes in the country, including those used by the air lines, aerial service operators, flying schools, private clubs and individuals, associations, experimental institutes and airplane factories.

During 1932 there were 12 German firms engaged in aircraft manufacturing, as well as two firms manufacturing airships. The German aircraft industry turned out 220 airplanes during 1931, including 43 planes intended for export, but 1932 production was considerably below this level. The principal manufacturers were: Albatros Flugzeugwerke G.m.b.H., Berlin; "Arado" Handelsgesellschaft m.b.H., Berlin; Dornier Metallbauten G.m.b.H., Friedrichshafen; Espenlaub Flugzeugbau, Duesseldorf; Fieseler Flugzeugbau, Kassel, Focke-Wulf Flugzeugbau A.G., Bremen; Flugzeugbau Max Gerner G.m.b.H., Frankfurt; Haller-Flugzeuge, Munich; Ernst Heinkel Flugzeugwerke G.m.b.H., Warnemunde; Junkers Flugzeugwerk A.G., Dessau; Leichtflugzeugbau Klemm G.m.b.H., Boeblingen; and Messerschmitt Flugzeugbau G.m.b.H., Augsburg. The airship manufacturers were: Luftschiffbau Zeppelin G.m.b.H., Friedrichshafen; and Wasser und Luftfahrzeugbau G.m.b.H., Seddin.

Six firms were engaged in the manufacture of aircraft engines. They were: Argus Motorenengesellschaft m.b.H., Berlin; Bayerische Motorenwerke A.G., Munich; Hirth Motoren G.m.b.H., Stuttgart-Zuffenhausen; Junkers Motorenbau G.m.b.H., Friedrichshafen; Maybach Motorenbau G.m.b.H., Friedrichshafen; and Siemens and Halske A.G., Flugmotorenwerk, Berlin-Spandau.

All aircraft manufacturing and operation in Germany was commercial, because Article 198 of the Treaty of Versailles forbids military or naval air forces and the construction or maintenance of military airplanes of any kind.

Great Britain

Imperial Airways, Ltd., continued in 1932 to represent the major civil aviation activity in the United Kingdom. Operating as the only air transport company in Great Britain providing service on regular schedule, Impe-

rial Airways continued its three principal European services: London-Paris, London-Paris-Basel-Zurich and London-Brussels-Cologne, as well as its important Empire routes: London-Karachi-Delhi, London-Cairo-Kisumu-Mwanza, and London-Cape Town.

Organization of the final sections of the London-Cape Town airway from Kenya via Tanganyika Territory and Northern and Southern Rhodesia to the Union of South Africa was completed and in full operation during the 1932 season. The through weekly service was inaugurated January 20, 1932, the time-table allowing ten and one-half days for the



FOR AFRICAN SERVICE

New four-engined Imperial Airways' airliner "Atalanta" to be used on the air route from Cairo to Cape Town.

8,000 mile flight. It was expected that the time for the trip would be reduced as more operating experience is gained and the faster aircraft being built for the service in 1932 put into use.

The company continued to give consideration to the possibility of extending its London to India service on to Australia. Experimental flights over the 10,000 mile route had been carried out, and it was hoped that political and other obstacles could be overcome in 1933 to insure operation of the route, which would be one of the longest in the world. The experimental flights were scheduled to take 15 days, but it was expected that service could be maintained on a schedule of from 11 to 12 days. As will be seen from an earlier chapter on "History Making Flights in 1932,"

British light planes manned by pilots with a penchant for record breaking flights had linked England and Australia in little more than eight days.

Imperial Airways also had under review the possibility of operating, in conjunction with American and other foreign interests, a service between Europe and America via the Azores and Bermuda. At the request of the Governor of Bermuda, a representative proceeded there to assist local administration officials in the selection of an airport for the colony. It was contemplated that this airport would be used first for tourist traffic between Bermuda and the United States. Attention was being given to the question of the most suitable type of aircraft for the operation of a trans-Atlantic air line.

During Imperial's heaviest traffic season (April 1 to September 30) 27,369 passengers were carried in 1932 on scheduled services and 10,096 passengers were carried on charter and short flights. During that period a total of 511,060 miles were flown and 687,545 ton-miles of traffic (all classes) were carried. Since the British fiscal year ends on March 31, these figures (which show an increase in passenger traffic) can be compared with the entire year 1931-32 when 24,192 passengers were carried in scheduled service, 6,432 in charter and short flights, for a total of 719,060 miles flown with 643,119 ton-miles of traffic. All of these figures are for the European services exclusively.

On the Empire routes, traffic for the six months ending September 30, 1932, totaled 2,130 passengers and 61 $\frac{3}{4}$ tons of mail, freight and excess baggage flown 565,000 miles. For the fiscal year 1931-32, 1,927 passengers and 107 $\frac{1}{2}$ tons of mail, freight and excess baggage were flown a total of 1,002,902 miles. During 1932, Imperial employed 32 planes on its regular scheduled air lines, manned by 35 pilots, 12 engineers, and 18 wireless operators.

Like the air transport lines of Germany and France, Imperial Airways received substantial aid from the Government through cash subsidies and other grants. Contractual subsidy payments to the company for its European, Indian and African service in 1932 amounted to £541,000. Vote 8 (Civil Aviation) of the British Government also provided a subsidy of £8,500 (a decrease of £6,500) for light airplane clubs and £1,500 (a decrease of £3,500) for the National Flying Services, Ltd., which instructed students and carried on aerial service work.

In addition to National Flying Services, Ltd., there were five or six other aerial service companies doing a general business, including charter flights, sightseeing, aerial photography and advertising, etc. One of the chief centers for private flying was maintained by one of these companies, Airwork, Ltd., which operated the Heston Airdrome outside London.

It was difficult to learn, even when British official figures were consulted, how many airplanes were employed for private flying only, because

planes licensed and sold abroad were not segregated from those retained in the United Kingdom and because the figures on new certificates of airworthiness did not show how many of these referred to new aircraft. However, the 1931 report on civil aviation showed that 924 airplanes had registrations in force as compared with 846 at the close of 1930, and 600 in 1929. These figures included all aircraft in civil use, including air transport, aerial service, private flying, etc. There were about 2,000 pilots holding licenses in Great Britain in 1932.

The aircraft manufacturing industry in Great Britain received its great-



IMPERIAL AIRWAYS' "HELENA"

"Helena," western type Handley-Page four-engined transport, used by Imperial Airways on its heavily travelled routes.

est support from Government contracts for military airplanes. Because a major share of the production was military aircraft, no production statistics for either commercial or military airplanes or engines were made public. It was known, however, that Great Britain maintained one of the world's largest military air establishments. The manufacturing industry was strongly entrenched as a result of the policy of the British Government to provide the industry with sufficient contracts to keep all manufacturing facilities intact. It is interesting to note that the list of British aircraft and engine manufacturers, holding membership in the Society of British Aircraft Constructors, Ltd., in 1929 and published on Page 281 of "The Aircraft Year Book for 1930," was identical with the list of firms in business in 1932. However, it might be well to add the names of several other

aircraft and engine companies, although not members of the Society, which were in business in 1932. They were: Arrow Aircraft, Ltd., Leeds; A.B.C. Motors, Ltd., Walton-on-Thames, Surrey; William Beardmore and Company, Ltd., Glasgow; British Salmson Aero Engines, Ltd., New Malden, Surrey; Civilian Aircraft Company, Ltd., Hedon, East Yorks.; Comper Aircraft Company, Ltd., Edgware, Middlesex; General Aircraft, Ltd., Croydon, Surrey; Martin's Aircraft Works, Higher Denham, Bucks.; Redwing Aircraft Company, Ltd., Wallington, Surrey; and Pobjoy Airmotors, Ltd., Hooton Park, Cheshire.



PRINCE OF WALES EMBARKING

The Prince of Wales entering Imperial Airways' air liner "Heracles" at Croydon for flight to Copenhagen.

Greece

The Greek Air Transport Company, formerly known as "Icaros," accounted for the chief domestic activity in civil aviation in Greece during 1932, completing its first year of operation July 10, 1932. The lines maintained were: Athens-Saloniki and Athens-Jannina. The company's planes flew 350,603 kilometers with 6,718 passengers, 7,851 kilograms of mail and 96,912 kilograms of express during its first year.

In addition to the lines of the domestic company, Greece was connected with western and northern Europe and with Asia by seven international air transport lines using Greek airports as intermediate stations. According to agreements concluded with French and German companies, one-day services from Saloniki to Paris and to Berlin were inaugurated in May,

1932. An Italian line also opened a service from Bari, Italy, to Sofia, Bulgaria, with a stop at Saloniki in Greece.

An aircraft exhibition was held for the first time in Athens in April, 1932, with British, French, Czechoslovak and Italian manufacturers participating. A few airplanes were exhibited, chiefly military units owned by the Greek Air Ministry. No new aircraft were purchased by the Greek Government during 1932, but efforts were made to improve existing airports. The number of military airports was increased to four, first class commercial airports to six, second class commercial fields to four, and emergency landing fields to 35.

Hawaii

The United States Army and Navy squadrons and Inter-Island Airways, Ltd., the only commercial operating company, accounted for all the aviation activity of this mid-Pacific American territory, which was considered by many as a possible key base for future trans-Pacific services of both airships and long-range flying boats.

Four Sikorsky 38 (Pratt and Whitney Wasps) amphibions and a Belanca Pacemaker (Wright Whirlwind) were used by Inter-Island Airways to maintain schedules calling for 5,000 miles of flying weekly. The company flew more than 250,000 miles during 1932 and carried 8,500 passengers, somewhat of a decrease from 1931 figures. Business men in Hawaii were making efforts to obtain regular mail service through the facilities of this line. The company's routes were: Honolulu-Hilo and Honolulu-Maui, six times weekly; and Honolulu-Kauai, three times weekly. The company celebrated its third anniversary November 11, 1932.

The United States Army Air Corps was based at Wheeler Field and Luke Field near Honolulu, and the Naval Air Station was at Pearl Harbor, 10 miles away.

Hungary

The Hungarian Air Traffic Company (Magyar Legiforgalmi R.T.), together with the Deutsche Luft Hansa (German) and "CIDNA" (French) operated 1,770 kilometers of routes in Hungary during 1932. Regular service was maintained on four routes: Budapest-Vienna; Budapest-Klagenfurt-Venice; Budapest-Belgrade; and Budapest-Pecs-Káposvár. Two other new lines were opened and operated in 1932: Budapest-Nyiregyháza and Budapest-Miskolc.

Hungarian air traffic in 1931 was reported as follows: 776,852 kilometers flown with 6,564 passengers, 122,304 kilograms of mail, and 188,068 kilograms of goods carried. There were no accidents in Hungary during 1932. The Hungarian and French companies maintained five to seven planes in the country for their services, while the German company sta-

tioned no planes there since it merely operated over Hungarian territory. The Hungarian company, which also operated taxi service as well as its scheduled routes, received a subsidy of 200,000 pengő (\$35,000) in 1932 and was to receive a similar amount in 1933.

There were 15 privately owned airplanes in Hungary in 1932, four of which were owned by individuals. There was but one first class airport, Mátyásföld, near Budapest. The Manfred Weiss Airplane and Motor Manufacturing Company at Csepel, Hungary, was the only manufacturer of airplanes in the country, having patent rights to Fokker, Caproni, and Heinkel designs. Military aviation was prohibited by the Trianon Treaty of 1920. All civil activities were under the Royal Hungarian Ministry of Commerce.

India

Imperial Airways (British), Air Orient (French) and K.L.M. (Dutch) continued to link British India with Europe in 1932, the former operating a weekly service to Karachi and the latter two continuing on to Saigon and the Netherlands East Indies via Jodhpur, Allahabad and Calcutta.

October 15, 1932, marked the inauguration by Tata Sons, Ltd., of a Karachi-Bombay-Madras air mail service to connect with Imperial's plane arriving from London on Friday of each week. Puss Moths were employed in this service, which arrived at Madras each Sunday morning, with a saving of time over surface transportation of more than one full day to Bombay and more than two days to Madras. The Delhi Flying Club operating from Delhi to Karachi via Jodhpur, performed a similar function.

The interest of British residents and Indians in flying clubs resulted in the importation of some new equipment during 1932, chiefly de Havilland Moths and a few Blackburn Bluebirds. A four-place Stinson cabin monoplane of American manufacture was purchased by a wealthy Indian at Bombay. India was among the most important countries of destination for British aircraft in 1932. Most of these imports, however, were for the use of the Royal Air Force. More than 350 airplanes were maintained in India by the Royal Air Force.

Irish Free State

Dublin was linked with Berlin for the first time in 1932 when K.L.M. (Dutch) undertook an experimental mail and passenger round-trip flight over the route on October 22 with a tri-motored Fokker. Fourteen passengers and a load of mail were flown to Berlin, the return trip with another mail and passenger load being made the following day.

The Irish Aero Club flew 934 hours between January 1 and October 31, 1932, in its three de Havilland Moth training planes. Irish Air Lines,

Ltd., was formed in March, 1932, and visited some 30 fields throughout the country for passenger flights with two Avro three-place planes and a Blackburn Bluebird. Sixteen aircraft were registered in the Irish Free State late in 1932, and 31 persons held pilot's licenses, 10 of them being qualified for public transport work. Iona National Airways, Ltd., used a five-place cabin biplane for taxi work.

Military aviation in the Irish Free State advanced with the appointment of a Director of Military Aviation on the General Staff of the Department of Defense. The Air Corps School at Baldonnel was maintained, and the Corps' equipment supplemented by the addition of several Avro training planes.

Italy

Aviation continued to occupy a very prominent place in the national life of Italy during 1932, the Fascist Government, headed by Mussolini, seeing in it the personification of the modern speed, efficiency and directness of action upon which the Government based its policies. For both military and civil purposes, aviation had become regarded as one of the most important determining factors in the history of the next few decades.

While Italy had no spectacular flight to celebrate in 1932 such as General Balbo's crossing of the South Atlantic early in 1931 with an entire squadron of flying boats, Rome was given a real taste of an "air raid" in modern style when the Eternal City was subjected to a 48 hour attack in September, 1932, met by anti-aircraft fire and pursuit squadrons. Realism was lent to the exercises through the dropping of smoke bombs by day and flares by night. Traffic was stopped on Rome's streets and the civil population was required to conduct itself as though the city actually was being raided by a hostile air force.

In May, 1932, the First Congress of Trans-Oceanic Fliers was held in Rome, and considerable data on the subject of long distance flying were compiled and codified. Italy's 1931-32 aviation budget amounted to about \$35,000,000 of which about \$3,700,000 was for civil aviation. The 1932-33 budget carried practically the same figures. In each year, commercial air lines receive about \$3,500,000 in subsidies on the basis of kilometers flown.

Few new planes were added to the military or civil establishments during 1932, and it was evident that Italy planned to provide for her own needs in this field in future years. In discussing his budget in the Parliament early in 1932, General Balbo declared that henceforth Italy would depend upon planes not only built in Italy, but designed in Italy. During 1931 and 1932, the Italian aircraft manufacturers obtained substantial orders for military planes from Russia and Central European countries, in each case assisted by the Government's export credit guarantee scheme.

Civil aviation continued to progress. In 1931 all previous records were

broken for distance flown, and passengers, mail and express carried. Figures for the first six months of 1932, compared to the same period in 1931, show an increase of 31 per cent. in mileage, two per cent. in passengers, 155 per cent. in mail, and a decrease of 20 per cent. in express. During the first six months of 1932, two new lines were inaugurated, one from Milan to Zurich and the other in the North African Colonies linking Tripoli, Sirte, Bengasi, Derna, and Tobruk. The latter service was operated by a newly formed company called the Società Anonima Nord Africa Aviazione, using Caproni planes, and it was planned to extend the service to other Italian colonial points.



ITALIAN PRINCESS ON FLIGHT

The Princess of Piedmont boarding a plane of the Aero Espresso Italiana for a flight to Brindisi in April, 1932.

An agreement was signed in July, 1932, between the Italian and the Czechoslovakian governments for a line between Trieste and Prague, but operating plans had not been completed late in 1932. In April, 1932, the Trans-Adriatica, the pioneer civil aviation company operating from Rome to Venice and Vienna with shorter lines at the head of the Adriatic, was merged into the Società Aerea Mediterranea, which operated the principal lines from the mainland to Sicily, to North Africa, and to Albania. Other Italian air lines in operation in 1932 included: Società Italiana Servizi Aerei, Società Anonima, Navigazione Aerea, Aero Espresso Italiana, Società Avio Linee Italiane, and Adria Aero Lloyd. A study of the accompanying map

will indicate the extent of their operations. All flying in Italy in 1932 was by day, no night routes being operated.

Private flying remained almost non-existent, there being only 44 privately owned planes in the country on October 1, 1932. There were 86 aero clubs in operation, largely supported by the Government, which were expected to develop interest in private ownership.

There were only eight aircraft manufacturers and four engine producers active in Italy during 1932, turning out 57 airplanes and 64 engines in the first nine months of 1932. This could be compared with 70 planes and 52 engines manufactured in all of 1931. Fiat, Alfa-Romeo, Isotta



ITALY'S AIR MINISTRY

Housed in a building of its own, the Italian Air Ministry in Rome directs Italy's development of aviation.

Fraschini, and Piaggio were the chief engine manufacturers. The eight active aircraft manufacturers were: Aeroplani Caproni, Milan; Cantiero Riuniti Adriatico "C.R.A.," Trieste; Officine Ferroviarie Meridionali "O.F.M.," Naples; F.I.A.T., Turin; Cantieri Aeronautici Bergamaschi "C.A.B.," Bergamo; Società Idrovolanti Alta Italia "S.I.A.I.," Milan; Costruzioni Meccaniche Aeronautiche "C.M.A.," Marina di Pisa; and Società Italiana Ernesto Breda "Breda," Milan.

While no official figures were available on the size of the Italian Air Force, Italy was known to have one of the three largest military air establishments in the world. Upon the occasion of the tenth anniversary of

Fascism, the Government reported that its Air Force had grown from 72 planes in 1922 to 1,500 planes in 1932.

Japan

Japan looked to air transport as an important factor in linking its maritime territory with the scene of heavy economic interests in Manchuria on the mainland, and took steps in 1932 to subsidize a new air line formed to provide service into Manchuria.

The Manchoukuo Air Traffic Company, Ltd., was organized September 27, 1932, at Changchun, China, as a joint stock company in which the South Manchurian Railway and the Government were to have the largest interests. The company was promised the support of the Japanese Government through subsidies for the establishment of two regular services: Dairen-Mukden and New Wiju-Harbin. Earlier in the year Japan had used aircraft extensively in its occupation of Manchuria.

The Japan Air Transport Company (Nippon Koku Yuso Kabushiki Kaisha) continued to be Japan's most important air line, operating 1,290 miles of routes: Tokyo-Osaka, Osaka-Fukuoka, Fukuoka-Urusan, Urusan-Keijo, Keijo-Heijo, and Heijo-Dairen. Twelve round trips each week were made on the first route and six trips each week made on the other routes. The company accounted for 90 per cent. of Japan's air transport operations, which totaled in 1931: 1,219,532 miles with 7,675 passengers, 30,025 kilograms of freight, and 37,136 kilograms of mail.

Four other air lines were in operation in 1932. They were: Nippon Koku Yuso Kenkyu-jo, providing six round trips each week between Osaka and Matsuyama, 180 miles; Tokyo Koku Yuso-sha, flying three round trips a week between Tokyo and Shimizu, 162 miles; and Asahi Teiki Koku-kai, serving Tokyo and Niigata, 236 miles, with three round trips a week during the summer season.

Japan Air Transport Company used Whirlwind-powered Fokkers of American and Dutch manufacture on its routes. There was virtually no private flying in Japan, only four airports being open to the public, and those only when specific permission was granted for their use upon application. Two newspapers at Osaka, the "Asahi" and "Mainichi," owned nine and eight planes, respectively, which were used extensively. There were 11 active aircraft and engine manufacturers in Japan in 1932, most of them producing planes and engines under patents of other countries.

Japan's Military Flying Corps, one of the largest in the world, employed planes of American, German, British and French manufacture although most of its equipment was produced in Japanese factories. The Corps had 26 squadrons and more than 600 planes. It saw service in 1932 in the bombing of Shanghai and in several other engagements.

Mail, passenger and express service on daily schedule was provided from May 1 to October 15, 1932, by the German-Russian Air Traffic Company "Deruluft" on its Berlin-Koenigsberg-Tilsit-Riga-Tallinn route, with Latvia served through the stop at Riga. While the number of passengers in and out of Riga increased in 1932 to a total of 950, transportation of freight was comparatively small, totaling 1,099 kilograms from German airports to Riga and 100 kilograms from Riga to Berlin.

A new air line was established and operated in 1932 by the Polish Air Transport Company, Polskie Linje Lotnicze Lot, on the route Warsaw-Vilno-Riga-Tallinn, thrice weekly, with Polish-built planes of the Fokker type. Service was inaugurated August 18, 1932, and continued until September 30, 1932. One hundred and forty passengers were carried. As a result of competition with the "Deruluft," the latter company reduced its rate from Riga to Tallinn from 55 lats (\$10.60) to 25 lats (\$4.80).

Netherlands

The Royal Dutch Air Lines for Netherlands and Colonies (Koninklijke Luchtvaart Maatschappij voor Nederland en Kolonien), more commonly known as K.L.M., continued to carry the banner of Dutch civil aviation in 1932 with marked success.

K.L.M. inaugurated two new services in 1932, one from Amsterdam to Enschede, in the center of the Dutch cotton goods and machinery manufacturing section, and the other from Amsterdam via Rotterdam to Haamstede and Flushing, serving the southern part of the Province of South Holland and the Province of Zeeland which are composed mainly of islands and are rather inaccessible.

Unlike past years, K.L.M. entered a new policy of maintaining its routes in Europe and to the Far East throughout the year, with the exception of the new short line from Amsterdam to Enschede, which was discontinued during the winter months. K.L.M.'s chief routes in Europe were: Amsterdam-Rotterdam-London, Amsterdam-London, Amsterdam-Rotterdam-Paris, Amsterdam-Hamburg-Copenhagen-Malmo, and Amsterdam-Bremen-Hamburg. The company also operated one of the longest routes in the world, extending from Amsterdam to the Netherlands East Indies, using a route through Central Europe during the summer months and via the Mediterranean in winter. A glance at the accompanying map will indicate the route used for this service.

During the first eight months of 1932, K.L.M. flew 1,325,000 miles with 15,656 passengers, 187,000 pounds of mail, and 1,291,000 pounds of goods. This might be compared with 1,615,000 miles flown with 19,911 passengers, 203,148 pounds of mail and 1,522,006 pounds of goods during

the entire 12 months of 1931. The Dutch East Indian route was not heavily patronized by passengers, only 22 persons being booked from Amsterdam to Batavia and 300 others carried to way points since the service was inaugurated, but it formed an important link between the Netherlands and her far off colonies. The through fare was reduced during 1932 to 1,750 florin (\$700), a drop of \$300 from the fare charged when the service was started.

Thirty planes built by the Dutch Fokker plant, some of them powered with American-built Pratt and Whitney Wasp and Wright Whirlwind

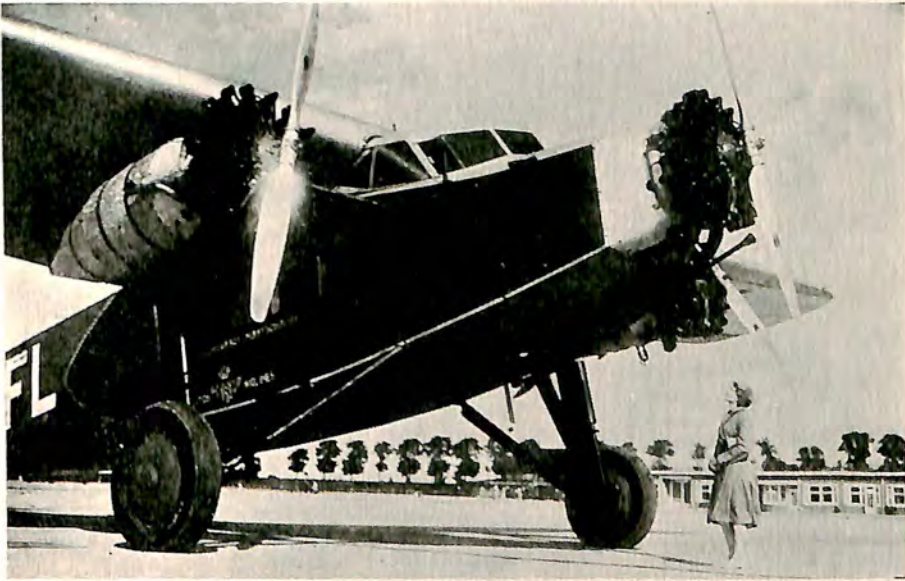

TO JAVA WITH WASPS

From Amsterdam to Java, the Royal Dutch Air Lines use these Wasp-powered Fokker F12 passenger transports.

engines, were used to maintain the K.L.M. services. They were manned by 33 pilots, 13 of whom were assigned to the Dutch East Indian route. The company received a subsidy of about \$400,000 annually from the Netherlands Government. Losses sustained by K.L.M. during 11 years of operation totaled 5,997,354 florin (\$2,410,936.30), which amount was covered by subsidy grants of the Government.

Private flying in the Netherlands was limited to 15 sport planes, which 51 licensed private fliers were qualified to fly. The National Aeronautic School celebrated its fifth anniversary September 10, 1932, with 136 students

registered, making a total of 196 students under instruction during five years of operation.

Four aircraft manufacturers, headed by the original Fokker factory, were in operation in 1932. No production statistics were made public in the Netherlands, but it was known that 12 planes valued at \$294,400 were exported during the first eight months of 1932, chiefly to the Netherlands East Indies. No engines were manufactured in the country, most of them being imported from the United States, as the table of aeronautic exports in Part IV of this volume, "Flying Facts and Figures," will indicate.



CANALS AND AIRPORTS

Schiphol Airport at Amsterdam, Holland, is several feet below the level of the picturesque Dutch canal.

The Netherlands Army Air Service had 87 airplanes in service in 1932, including 10 pursuit planes, 40 observation and scouting planes and 37 training planes. The Naval Air Service had 144 planes, 55 of which were in the Dutch East Indian Service.

Netherlands East Indies

The Royal Dutch Indian Air Line (Koninklijk Nederlandsch-Indische Luchvaart Maatschappij), better known as K.N.I.L.M., continued its intra-East Indian service in close affiliation with K.L.M., although it was operated as a separate company. Based at Batavia, Java, the line operated twice

daily to Bandoeng, daily to Surabaya, and weekly to Singapore and Medan with a fleet of tri-motored Fokkers, some of which were powered with Pratt and Whitney Wasp engines. During the first six months of 1932, 425,550 kilometers were flown with 10,754 passengers, 9,258 kilograms of mail, and 32,539 kilograms of freight. In 1931 the line flew 919,794 kilometers with 17,212 passengers, 18,818 kilograms of mail, and 92,160 kilograms of freight. The freight consisted chiefly of fresh flowers, fruits and vegetables.

There were seven privately owned airplanes and 14 private fliers in the colonies. The Netherlands East Indian military air service, although equipped chiefly from the Dutch Fokker factory, had several Curtiss-Wright P-6 pursuit planes in service.

New Zealand

Although commercial aviation continued to remain in a somewhat backward stage in New Zealand, the flying club movement was an important factor in building up interest in private flying. Fifty aero clubs, aided by lotteries legalized by the Government and cash subsidy grants, accounted for the presence of 400 licensed pilots and 61 planes in a country no larger than the State of Colorado and with a total population of 1,500,000 persons. Interest in American planes among private fliers was heightened by the successful purchase and operation of two American planes.

The only commercial concerns operating in New Zealand were the Gisborne Air Transport Company, serving Gisborne and Napier, and the New Zealand Airways, Ltd., providing service from Dunedin to Timaru.

Norway

The Norwegian Air Transport Company (Morske Luftruter A/S) in cooperation with the Deutsche Luft Hansa again operated passenger and express service between Oslo and Travemunde, although the service in 1932 was operated only three months as compared with four in previous years. Although the total traffic in 1932 was smaller than in 1931, the monthly average was higher because of the shorter season. The 1932 traffic totaled 111,000 kilometers flown with 582 passengers, 807 kilograms of mail and 859 kilograms of express. The company received a total subsidy of 12,000 kroner, half contributed by the City of Oslo and the other half by the Norwegian Government.

At the close of 1932, the Army Air Service was testing several types of Swedish and British pursuit planes with a view to adopting the one best adapted to its purposes. Both the Army and Navy had air units in service.

The Junkers Luftverkehr Persia, which for five years held a monopoly on civil aviation in Persia, discontinued operations during the year and negotiations for the operation of intra-Persian services by Imperial Airways were unsuccessful. Imperial's planes found it necessary to fly via the Bahrein Islands, avoiding southern Persia, because its permission to fly over Persian territory expired at the same time as the Junkers company. Persia, therefore, was without air service at the close of 1932.

To supplant the six Junkers planes used by the Persian army, orders were placed during 1932 for a quantity of British Hawker fighters and some de Havilland Moths for training purposes. The Hawkers were to be equipped with Pratt and Whitney Wasp engines, 40 of which were ordered from the United States late in 1932.

Philippine Islands

The Philippine Aerial Taxi Company at Manila maintained cabin plane service from Manila to Rosario Field, from which the cities of Northern Luzon and the summer capital, Goguo, could be reached by quick motor transportation. Inter-island charter flights with pontoon-equipped planes also were made, licensed American pilots being employed on all services. During 1932 a company was formed for short service from Iloilo across the channel to various sugar centrals on the west coast of Negros Island. The Philippine Legislature effected regulations identical, with few minor exceptions, to the United States Air Commerce Act.

Poland

The Polish air line "Lot" inaugurated a new service August 17, 1932, between Warsaw and Tallinn, with stops at Wilno and Riga, using 10 passenger planes built at the Government plant in Warsaw. Service was maintained throughout the winter on the Warsaw-Wilno section.

Other services of the Polish line, whose stock was held by the National Treasury and several Polish municipalities, included: Warsaw-Katowice, Warsaw-Krakow-Katowice-Brno-Vienna, Warsaw-Poznan, Warsaw-Bydgoszcz-Danzig, and Warsaw-Lwow-Cernauti-Bucharest. All services were operated thrice weekly except the latter, which was flown once a week in the winter. During the summer season, the line was extended to Sofia and Saloniki and operated thrice weekly. The French line "CIDNA" also provided connections between Warsaw and Prague.

During the first six months of 1932, the line flew 605,600 kilometers with 4,221 passengers and 156,881 kilograms of freight, baggage and mail. During 1931, the company flew 1,502,349 kilometers with 14,180 passengers and 420,405 kilograms of mail, freight and baggage. There

were no fatalities on the scheduled air line routes during the 18 months. Thirty planes and 20 pilots were employed to maintain the services.

Four aircraft manufacturers and three engine factories were active during 1932, one of the engine plants being in production on Wright Whirlwind engines of American design. A new air terminal was under construction at Okecie, just outside Warsaw, at a cost of \$800,000.

The principal event in Polish military aviation during the year was the winning of the 1932 European Air Challenge competition for light airplanes in Berlin, August 21-28, by Lieut. Franciszek Zwirko of the Polish army flying a light plane of Polish design and construction.

Portugal

Although its comparative isolation from other sections of Europe appeared to make the establishment of air lines desirable, Portugal had no commercial air service of any kind. Civil aviation was limited to three or four privately owned airplanes in the country. The terms of the transport monopoly granted by the Portuguese Government in September, 1930, to Cia. Portuguesa de Aviação were amended February 12, 1932. The grant called for the establishment of a half dozen services in from 12 to 30 months.

The Army air service was reported to be badly in need of new equipment, and during 1932 representatives of many foreign manufacturers, including Americans, demonstrated their planes. The country had very strict governmental regulations limiting the movements of civil or visiting aircraft so much that it was considered doubtful whether civil aviation would advance very rapidly.

Rumania

During 1932 all aviation activities of the Rumanian Government were consolidated in a specially formed department headed by Radu Irimescu, Under Secretary of State for Aviation, and it was expected that aviation would experience considerable expansion in 1933 under his guidance.

Hampered by lack of funds due to current economic conditions, civil aviation in Rumania was slowed up somewhat during the year. Three aircraft factories were idle most of the year, producing not more than 40 planes of all types of which about 35 were destined for military service.

Three air transport lines served Rumania. The Government line "LARES" maintained two routes: Bucharest-Galatz-Chisinau and Bucharest-Constantza-Balcic. Bucharest also was served by two foreign lines, the French "CIDNA" and the Polish "LOT," both of which already have been described.

Siam added two Boeing single-seater pursuit planes to its military air service, which consisted of 100 airplanes in 1932.

Aerial Service Company of Siam, Ltd., continued to operate the service into the interior of Siam, taken over from the Siamese Army in 1931, with four Puss Moth airplanes. It provided bi-weekly service between Korat-Ubon-Nakon Pnom, and during the first year of operation, which ended, April 1, 1932, 30,000 pounds of mail, 4,500 pounds of express and 40 passengers were carried.

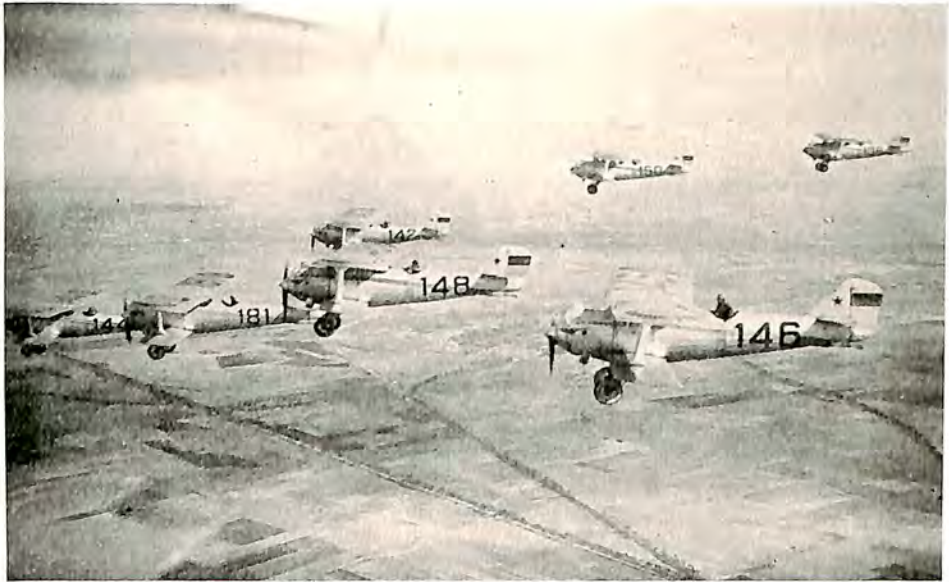

SPAIN'S AIR SQUADRONS

Seven Breguet army scout planes, manufactured in Madrid, are seen in formation just outside that Spanish city.

K.L.M. (Dutch) and Air Orient (French) continued their services through Siam with a stop at Bangkok on the way to Java and Saigon, both of which routes have been described earlier. Late in 1932 the Siamese were considering operation of the Bangkok-Hanoi link of the projected Imperial Airways' extension to China. With the proposed extensions, Europe would be brought within 11 days from Hong Kong and 13 days from Manila.

Spain

As a result of the action of the Spanish Chamber of Deputies September 23, 1931, all property of the Spanish air line "CLASSA" was expropriated, subject to suitable reimbursements, so that the line Barcelona-Madrid-

Sevilla was operated during 1932 by the State through its *Lineas Postales Aereas Espanolas*. Late in 1932, a private service from Madrid to Valencia was receiving consideration, and the long-projected route from Sevilla to the Canary Islands was to be inaugurated in 1933. Nine planes with eight pilots were used to maintain the Government-owned lines, which flew a total of 418,440 kilometers with 4,423 passengers, 56,095 kilograms of mail, 11,155 kilograms of newspapers, and 16,786 kilograms of merchandise during the first eight months of 1932.

There were 84 civil airplanes registered in August, 1932, six of which were of American manufacture. Spanish aircraft manufacturing, chiefly for the Army and Navy, was carried on by four companies, which produced 57 aircraft engines during the first nine months of 1932 as compared with 112 in all of 1931. The planes were built under foreign license agreements. Spain had under consideration a plan for building up its air defense by increasing annual appropriations for the military air arm until they reach 150,000,000 pesetas.

The *Deutsche Luft Hansa* (German), *Aéropostale* (French) and "SINA" (Italian) all operated international lines into Spain, touching at Barcelona. The principal aviation school in Spain, *Compania Espanola de Aviacion*, was closed temporarily in August when it completed its government contracts, having graduated 432 pilots, 43 of them during the first eight months of 1932.

Straits Settlements

The Straits Settlements were linked with Europe and parts of Asia through the services of the *K.N.I.L.M.* (Dutch), which provided a service from Batavia to Singapore and Medan, already described. The Singapore to Medan service was discontinued in April, 1932.

While there were no privately owned planes in Malaya, there were 60 licensed pilots of the Singapore and Kuala Lumpur flying clubs, which were partially supported by the Government and Royal Air Force reservists. A base for the Royal Air Force was maintained at Seletar.

Sweden

Adding a Wasp-powered tri-motored Fokker FXII and two Hornet-powered Junkers Ju-52 tri-motored planes to its fleet in 1932, the Scandinavian Air Express Line (*Aktb. Aerotransport*) maintained daily service in 1932 with the cooperation of *K.L.M.* (Dutch) from Malmö via Copenhagen to Amsterdam, and in conjunction with the Finnish Aero Company from Stockholm to Åbo to Helsingfors.

The three new American-engined planes were among the fastest in



SCANDINAVIAN AIR EXPRESS

American-made Hornets power the new Junkers JU-52 transport as it takes off from water near Stockholm.

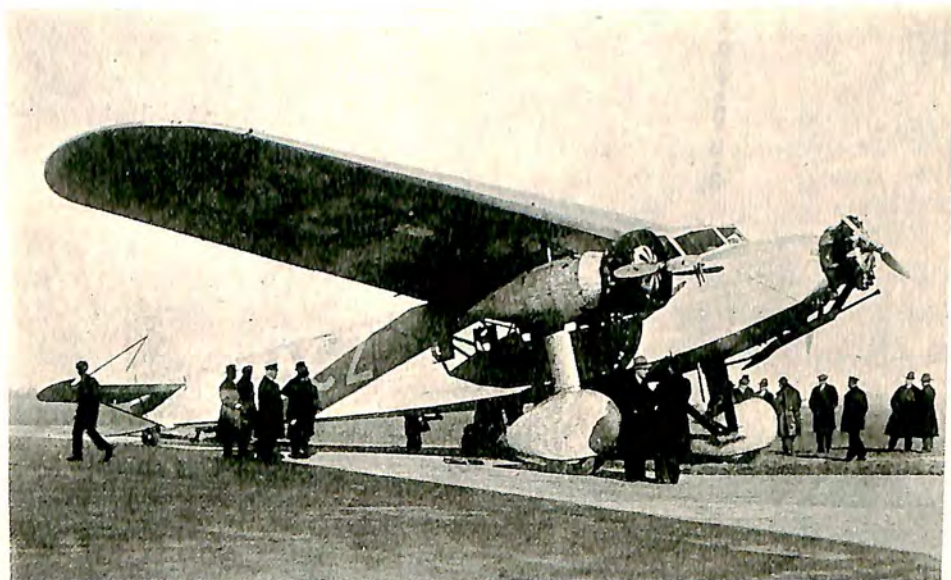

WASPS IN SWEDEN

New Wasp-powered Fokker F12 air liner belonging to Sweden's A.B. Aerotransport for Scandinavian Air Express.

service in Europe, and aided considerably in increasing traffic during 1932 despite a general decline in tourist traffic to Scandinavia. From March 1 to October 31, 1932, the planes of the Swedish company flew 400,379 kilometers with 5,635 passengers, 91,617 kilograms of freight and baggage, and 47,508 kilograms of mail. There was a 41 per cent. increase in passenger traffic on the Stockholm-Helsingfors line and a 45 per cent. increase in traffic on the Malmö to Amsterdam route.

The Nordic night air mail service, originated through Swedish initiative by test trips between Stockholm and London in the summer of 1928,

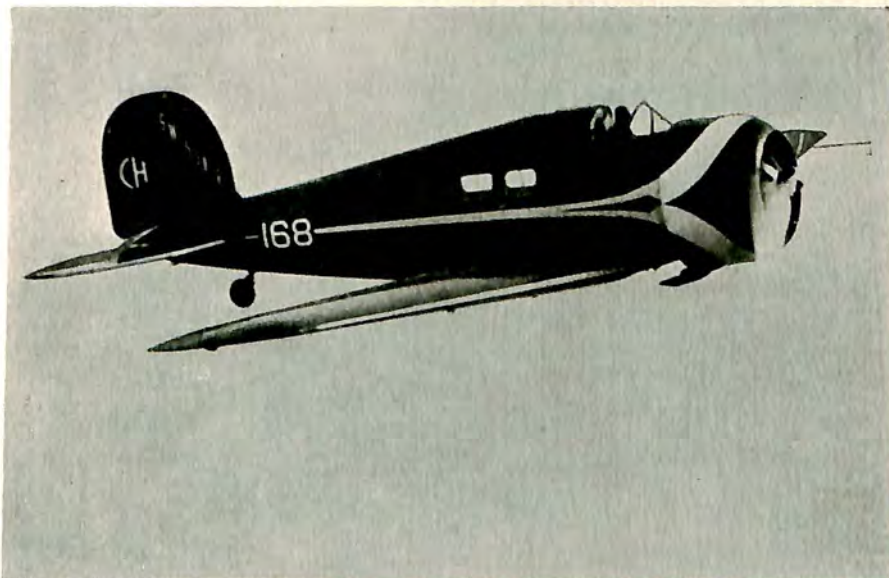

SWITZERLAND'S SPEEDY SERVICE

Providing Europe with its fastest air line service, these American-built Cyclone-powered Lockheed Orions are used by Swissair.

was maintained and expanded during each year since its inauguration. During 1932 service was provided from May 2 to October 31. The Swedish, Finnish, Danish, German and Dutch air traffic companies cooperated with each other in maintaining the night service. Widespread attention was attracted to the flight of the Prince of Wales and his brother, Prince George, with the Swedish Crown Prince to Northern Sweden during 1932.

Switzerland

With the addition of an American-built Lockheed Orion powered with a Wright Cyclone engine as the flagship of its air fleet, the largest Swiss air transport company, "Swissair," created widespread interest in its "fastest service in Europe" maintained between Zurich and Vienna in 1932.

Swiss aviation continued to maintain its 10-year record of 4,100,000 kilometers flown without a fatal accident. During 1931, three Swiss air transport companies, "Alpar," "Aero-St. Gallen" and "Swissair," flew 919,400 kilometers with 12,895 passengers, 182,163 kilos of freight, 22,444 kilos of excess baggage, and 131,183 kilos of mail. The Federal Air Office set aside 500,000 francs for subsidies in addition to 1,000,000 francs received from the Federal Post Office and 250,000 francs from regional interests.

Transport companies owned 28 planes July 1, 1932, while 64 airplanes were privately owned. There were 161 licensed civil pilots in 1932 as com-



NEW ZURICH AIR TERMINAL

American Lockheed of Swissair and German Junkers of Luft Hansa meet in front of new Swiss terminal at Zurich.

pared with 179 in 1931. "Swissair" cooperated with the Luft Hansa (German) in operating three services: Geneva-Zurich-Munich-Vienna, Geneva-Basel-Amsterdam, and Berne-Berlin. With Imperial Airways (British), "Swissair" participated in the operation of the Zurich-Basel-Paris-London service; and with Air Union (French) operated the Geneva-Lyons-Paris and Basel-Cherbourg services. The line Basel-Zurich-Munich-Prague was cooperatively maintained with the aid of a Czech company.

Turkey

The first Turkish air line was to inaugurate service in 1933 with the use of two Curtiss-Wright Kingbirds powered with Wright Whirlwind

engines, which were purchased in the United States in 1932. During 1932, the French line "CIDNA" linked Paris with Istanbul; an Italian line provided service from Brindisi to Istanbul; and the German Line, Luft Hansa, maintained a route from Berlin to Istanbul.

The Turkish Ministry of National Defense added to its military air equipment during 1932 with the shipment of 24 Curtiss-Wright Hawk pursuit planes, powered with Wright Cyclone engines, from the United States. Turkey was showing great interest in the development of both civil and military aviation, and new developments were expected in 1933.



AMERICAN HAWKS FOR TURKEY

Twenty-four Cyclone-powered Curtiss-Wright Hawk pursuit planes were shipped to Turkey in 1932 for military use.

Union of South Africa

Situated at the end of a spectacularly difficult flight record course, the Union of South Africa was stimulated considerably toward its interest in aviation through the frequent flights from England by British sport pilots. The local Union Airways operated Puss Moths between Cape Town, Port Elizabeth, Durban and Johannesburg with a branch from Kimberley to Windhoek. Imperial Airways, Ltd., inaugurated service in February, 1932, linking South Africa with England on a weekly schedule which required 11 days of flying as compared to 19 to 21 days by steamer. Several American Waco planes were imported into the Union in 1932, one of them being owned by the the Durban Aero Club.

The Soviet Government continued its development of an elaborate plan for civil and military aviation in 1932, inaugurating several new air line services and making substantial increases in the kilometers flown as well as in every traffic branch.

During the first nine months of 1932, the Soviet Civil Aviation Trust, controlling all air line development in the country, was reported to have operated lines totaling 47,000 kilometers in length as compared with 27,746 kilometers in all of 1931 and 26,487 kilometers in 1930. The total distance flown in the first nine months of 1932 was 4,164,353 kilometers as compared with 5,241,073 in 1931 and 3,961,671 in 1930. During the first three quarters of 1932, 21,420 passengers, 313,920 kilos of baggage, and 367,078 kilos of mail and newspapers were carried. The principal lines in operation during 1932 are shown on the accompanying map.

The Soviet Government also continued its manufacturing and engineering research programs aimed to provide the country with more than 4,000 civil airplanes alone by the close of 1933.

Yugoslavia

Aerial Communication, Ltd., or "Aeropot," the only Yugoslav air transport company, maintained only two services in 1932: Belgrade-Zagreb-Gratz-Vienna, 658 kilometers, and Belgrade-Skoplje-Saloniki, 584 kilometers. Three other services maintained during 1931 were discontinued in 1932.

Traffic in 1931 totaled 259,321 kilometers flown with 2,442 passengers, 1,804 kilograms of mail, 23,923 kilograms of freight, and 25,443 kilograms of baggage.

Aside from the State Aircraft Factory at Kraljevo, there were four or five smaller companies manufacturing aircraft in the country, but statistics on production were closely guarded because almost the entire output was used by the military services.

PART II

Manufacturing and Engineering Progress

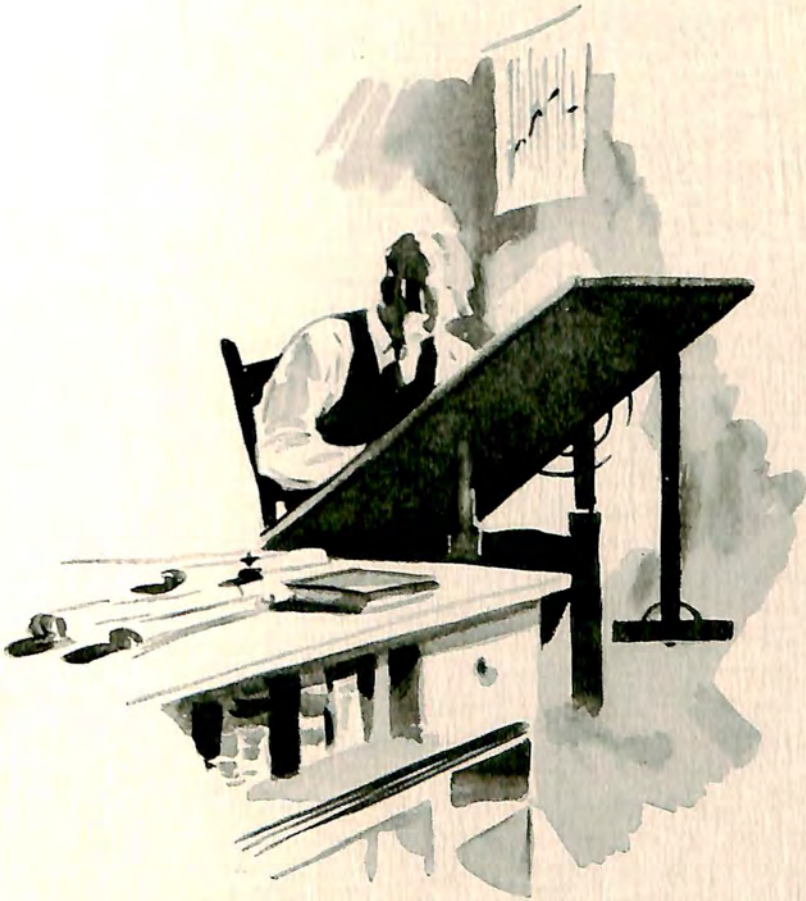

CHAPTER	PAGE
XVIII Trends in American Aircraft Design	237
Passenger and Mail Transports	257
Private Operation and Aerial Service.	271
Military Airplanes	296
XIX Advances in American Aircraft Engines	321
Engine Designs	333
XX Research Improves Component Aircraft Parts.	367

CHAPTER XVIII

TRENDS IN AMERICAN AIRCRAFT DESIGN

New Models For 1933 Show Many Design Refinements—Military and Transport Markets Dominant—Speed, Economy and Comfort Ruling Factors—Activity For Year In Major Factories Reviewed

WITH the age of expecting “miracles” in the form of “revolutionary designs” definitely passed, 1932 witnessed some very important advances in the refinement of American aircraft. It was particularly noteworthy that so many new designs and refinements of existing models should be introduced during a time when the world seemed to be so severely frostbitten by economic considerations.

There was no mistaking the fact that the market exerted a very definite influence on the trends in design in 1932, which was certain to become even more evident as the fruits of the year’s engineering were introduced in 1933 designs. The military and transport markets were predominant, with commercial business accounting for a very small part of total sales. Demands for greater economy came from all sides. Paradoxically, the demand for high priced equipment in the commercial market held up better than that for low priced aircraft.

In the transport and military markets, the demand for “speed and more speed” had a very profound effect on the year’s developments. With the passenger becoming an increasingly important revenue producer for the air line operator, the desire for more room for the passenger, comfortable chairs, adequate ventilation and heating, proper lighting and the absence of noise exerted its influence on design. Greater attention to details of design which would reduce the cost of maintenance and the employment of all-metal construction to facilitate maintenance were the result of closer cooperation between the designer and the air line operations and maintenance departments. Most of these conditions were achieved only after an increase in first cost, but it was felt that increased performance would mean greater revenue from faster schedules and reduced maintenance operations would reduce operating costs by keeping the airplane in the air a greater proportion of the time.

As seen through the critical eyes of more than a score of the nation's leading aeronautical engineers whose composite observations will be presented in this chapter, the year's design trends can be set down in a few sentences which speak volumes. Each engineer and designer submitted a comprehensive memorandum setting forth his appraisal of the year's trends for the editor to use in developing a composite picture for "The Aircraft Year Book for 1933."

Wing loadings, which tended decidedly upward in 1931, appeared to have reached a level in 1932 and some engineers believed they were pointing down. There was a steady increase in horsepower obtained from a given engine displacement through higher compression and increased supercharging, made possible through the use of fuels with higher anti-knock ratings. Biplanes continued to definitely lose ground after holding their own for a while, and the low-wing monoplane was challenging the position of its high-wing brother. There was considerable acceleration in the use of all-metal construction, with increased use of steel forgings where production in quantity was possible. Contrary to an earlier trend toward three or more engines for large transports, the use of more than two engines was losing favor in new designs. The retractable landing gear, an innovation two years earlier, was being incorporated into a major share of the new types, except those for sport and training. The demand for enclosed or partially enclosed types, as compared with conventional open types, was felt both in the commercial and military markets. More widespread use of radio and special navigation instruments resulted in the incorporation of such equipment into new designs.

Aerodynamically, the 1933 aircraft represented an advance over its predecessors. All new designs showed greater attention to the fairing of engine nacelles, wing fillets, strut intersections and landing gears. The results of studies on the optimum relation between nacelles and wings were incorporated in many of the new models. Aerodynamic brakes to decrease the floating tendency of clean airplanes while landing made their appearance. The wide adaptation of the single strut cantilever or wire braced landing gear was a result of the "cleaning up" process, where undercarriages were not completely retracted to reduce drag. Field experiment and wind tunnel research brought out new facts about interference drag and proper engine cowl shapes, which improved airflow around the fuselage to an extent where improved stability resulted. It was considered doubtful whether the tiny racing planes in the 1932 Thompson Trophy Race would have been controllable without use of this knowledge. While some designers consigned them to the classification of "gadgets," definite advances were made in the employment of "slots" and "flaps" to increase aerodynamic efficiency. The several designers devoting the greatest amount of attention to these devices reported that their latest research had definitely



CURTISS' BUFFALO PLANT

Main aisle in the Curtiss Aeroplane and Motor Company plant at Buffalo, N. Y., as seen from front of the building.



FINISHING AND DOPING

All parts and the completed airplane get their protective and finishing coats in this room of the Curtiss Buffalo plant.

taken "slots" and "flaps" out of the so-called gadget stage. Trailing rudder and elevator flaps to aid in trimming the airplane in flight were included on several new models.

While designers agreed that there was still room for further research in the aerodynamic field, especially on the problem of drag, several expressed the belief that the theoretical limit of minimum drag and maximum lift to drag ratio consistent with usable thickness and available maximum lift had nearly been reached. The use of wheel brakes and the improvement of landing facilities was considered to have made maximum lift a rather secondary consideration. An airfoil which answered properly for the other requirements generally had available sufficient maximum lift to make the landing speed reasonable.

Structurally, progress was evident in 1933 designs in the successful attempt to keep the increase in structural weight to a minimum consistent with extra strength, and in greater attention to detail design in an effort to save structural weight so as to offset the weight of such additional equipment as new instruments, radio, better passenger accommodations, etc. The year demonstrated more conclusively than ever that the internally braced metal monoplane was practical for both military and commercial designs. The search for improved structural strength and rigidity was productive through better application of metal, particularly alloy steels and aluminum alloys, for principal structures. Metal had completely replaced wood in 1933 designs. Fabric was still preferred by some manufacturers for covering, but metals were employed for fuselage and even wing coverings in some important types.

New metals, such as magnesium, stainless steels and special bronze, were employed to a greater extent in 1933 engines, but very little more in aircraft. Aluminum alloys and alloy steels were the chief materials being used in aircraft. The quality of alloy steels showed some improvement, with a large percentage of parts being used in the heat treated condition to obtain maximum strength with minimum weight. The Aluminum Company of America accomplished some rather remarkable results in increasing the strength of some of their aluminum alloys. The method of processing their 17ST material to give higher strength in a product known as 17RST, and the introduction of a new alloy known as 25ST, together with its complement 25RST, marked a very considerable advance in materials available for light structure.

Production methods were improved chiefly as an adjunct to new and more settled methods and types of construction, and in attention given to economical and efficient methods. Methods were improved in the forming of heat treated aluminum alloy sheet, the joining of sheet metal both by riveting and spot welding, and the more economical use of castings and stampings. All-metal construction resulted in the introduction of wider

use of large drawing dies, automatic equipment for riveting and spot welding, and special bending and forming equipment. The necessity for economical production led to simpler design, particularly in the construction of detail parts. The very limited current market for aircraft hampered the full development of production methods which would utilize the full advantages of such new features as metal construction and monocoque structures. Paradoxically, the market demanded high quality equipment at lower costs, but limited production sent manufacturing costs of new designs higher.

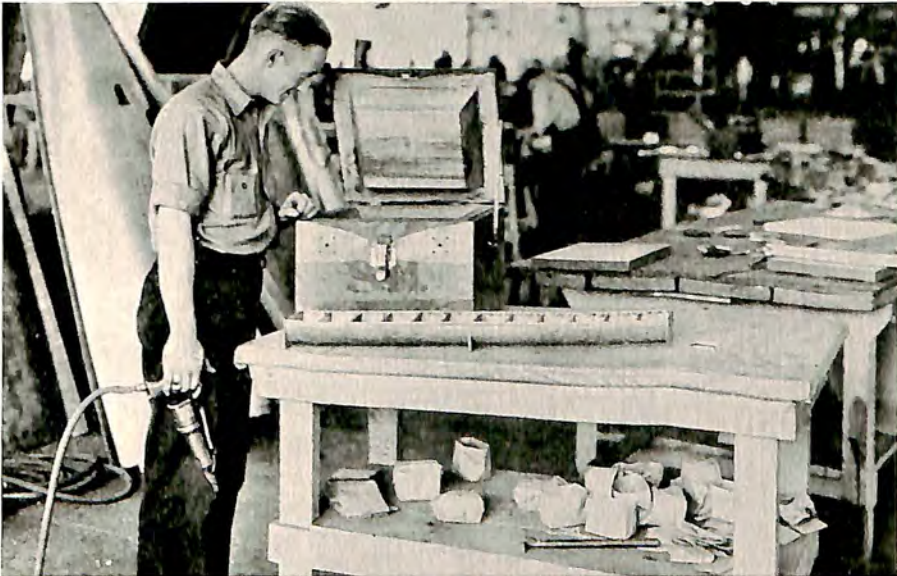

DRY ICE IN PLANE BUILDING

Riveter at Boeing Airplane Company selecting rivets from dry ice box, used to retard aging of rivets after heat treatment.

Size of air line transport planes has long been a moot question for discussion among designers and operators. From 1928 to 1931, the world witnessed a decided trend toward larger and larger transports. Planes were designed, built and flown with accommodations for from 18 to 100 passengers. The most interesting of these were described in the last three volumes of "The Aircraft Year Book." The economics of these planes was studied in actual operation. The results are expressed in the 1933 transport designs, which place a premium on high speed for from seven to fourteen passengers with added comfort as a feature. This relatively small unit was designed to permit more frequent operation of schedules with planes planned for economical operation. Only one new land super-trans-

port was completed in 1932, the Ford 14-A (4 Hispano-Suizas) with accommodations for 36 passengers. Its development was dropped late in 1932. The single exception to this new trend toward medium-sized transports was the continued development of giant amphibions and flying boats of the Sikorsky S-40 and S-43 types, adapted especially to carrying 36 to 50 passengers over long over-water jumps in the utmost of comfort.

The number of engines for economical and safe operation has been another favorite subject for discussion. Early advertising popularized the tri-motored transport for its "safety features" which resulted in widespread employment of these types to meet what the operator felt was the public demand. The 1933 trend appeared to be definitely toward bi-motored and single-motored transports, with the introduction of most new models in these classes.

No important advances were made during the year in solution of the problem of designing aircraft which would be safer in the hands of the unskilled operator. All aircraft incorporated a certain degree of stability in their design which made them easy to fly, but designers generally agreed that it would be a mistake to make the present airplane more stable. If anything the tendency in 1933 designs—outside the private commercial field—was toward complicating the problem of operation with the addition of such features as retractable landing gears, new navigation instruments for the pilot to watch, and radio. To offset this, there was a tendency to use automatic instead of manually operated controls for the power plant and to employ such devices as the Sperry Automatic Pilot to automatically compensate for lateral, longitudinal or horizontal changes in flight, making it possible for the pilot to devote attention to his navigation instruments and radio. The increased use of long travel oleo shock absorbers marked a definite trend toward building greater safety into the airplane, and greater attention to stability, control pressures and visibility aided simplification of operation to some extent. Several designers felt a definite need for combining the functions of several instruments on a single dial to simplify the pilot's task and cut down the size of the instrument installation.

Propeller design has always contributed its share to the advance of the completed product, and engineers watched with considerable interest the development of several competent controllable pitch propellers. These units offered an advance in performance not only through improvements in take-off and climb, but also in cruising speed and cruising economy. Most engineers agreed that this type of propeller, however actuated, would become standard equipment for all types of aircraft within a few years, with the possible exception of the training and small commercial types. Such propellers were absolutely necessary to the performance of the 1932 entries in the Thompson Trophy Race at Cleveland.

Trends in wing arrangement always have been interesting from the

time of the first "box-kite" like biplanes of the Wrights, through the attempts at triplanes and quadruplanes, to the more recent and modern monoplane. The monoplane, and more particularly the low-wing monoplane, appeared in the ascendancy among new designs for 1933. The United States Army made a distinct swing to low-wing monoplanes for new pursuit, bombers and attack planes ordered for 1932 and 1933 delivery, although the high-wing monoplane or sesquiplane held preference for observation aircraft. In the United States Navy, the biplane or sesquiplane arrangement was retained. New commercial transports ran the gamut

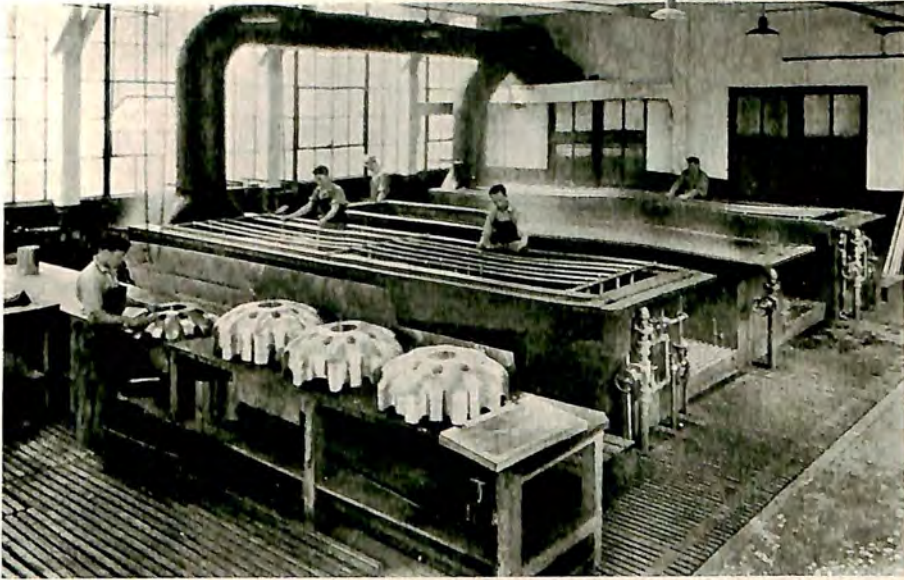

PROTECTION AGAINST CORROSION

All duralumin and aluminum parts for Boeing planes go through the anodic process to protect them against corrosion.

from low-wing monoplanes to sesquiplanes, to high-wing monoplanes and biplanes with wings of unequal span. In the private plane field, there was likewise no settling down to a single type of wing arrangement, although the monoplane was in the ascendancy.

The development of the autogiro, representing the only unconventional system of flight successfully introduced, was continued with some important refinements and the introduction of new models designed to increase its appeal to the available market. The autogiro remained a development strictly of the private commercial field, although several were delivered to the Navy in 1931 for experiment and its exponents claimed that this system of flight could be adapted to the larger transport field as future

advances in its design are made. Two licensees of the Autogiro Company of America, namely, the Kellett Autogiro Corporation and Pitcairn Aircraft, Inc., were in production on current models. Kellett introduced a new two-place cabin model known as the K-3 (Kinner C-5) during 1932, and Pitcairn added the PA-18 (Kinner R-5), a two-place autogiro with increased rotor area and improved control surfaces, to supplement its previous models, the PCA-2 and PCA-3, both of them three-place autogiros with Wright Whirlwind or Pratt and Whitney Wasp Jr. engines. For 1933 production, Pitcairn developed and flew a new four to five place cabin model to be known as the PA-19, powered with a Pratt and Whitney Wasp or Wright Whirlwind engine. Specification and performance tables on these models as well as three-view design drawings showing details of their construction will be found in the section immediately following this chapter.

In the commercial airplane field for the private or business owner, new models were brought out by the Aeronautical Corporation of America, Amphibions, Inc., Curtiss-Wright Airplane Company, Douglas Aircraft Company, Kreider-Reisner Aircraft Company, Monocoupe Corporation, Stearman Aircraft Company, Stinson Aircraft Corporation and the Waco Aircraft Company. While it did not introduce any new designs, the Bellanca Aircraft Corporation made some important refinements on models in production to increase their speed and efficiency. Details concerning the new models will be found in the specification and performance tables and design section immediately following this chapter as well as under the name of the company later in this chapter.

For the military market at home and abroad, the most active manufacturers to introduce new models included: B/J Aircraft Corporation, Bellanca Aircraft Corporation, Boeing Airplane Company, Consolidated Aircraft Corporation, Curtiss Aeroplane and Motor Company, Douglas Aircraft Company, Curtiss-Wright Airplane Company, General Aviation Manufacturing Corporation, Great Lakes Aircraft Corporation, Keystone Aircraft Corporation, Glenn L. Martin Company, Chance Vought Corporation and the Waco Aircraft Company.

For the passenger and mail transport market, new models were brought out by the Boeing Airplane Company, Consolidated Aircraft Corporation, Curtiss-Wright Airplane Company, General Aviation Manufacturing Corporation, Lockheed Aircraft Corporation, and Stinson Aircraft Corporation. With the opening of 1933, Douglas Aircraft Company was engaged in the development of a new commercial air line transport; and both Sikorsky Aviation Corporation and the Glenn L. Martin Company were busy with new designs for giant flying boats, capable of carrying 50 passengers over long water jumps, on contract for Pan American Airways, Inc.

The export market aided considerably during 1932 in providing addi-

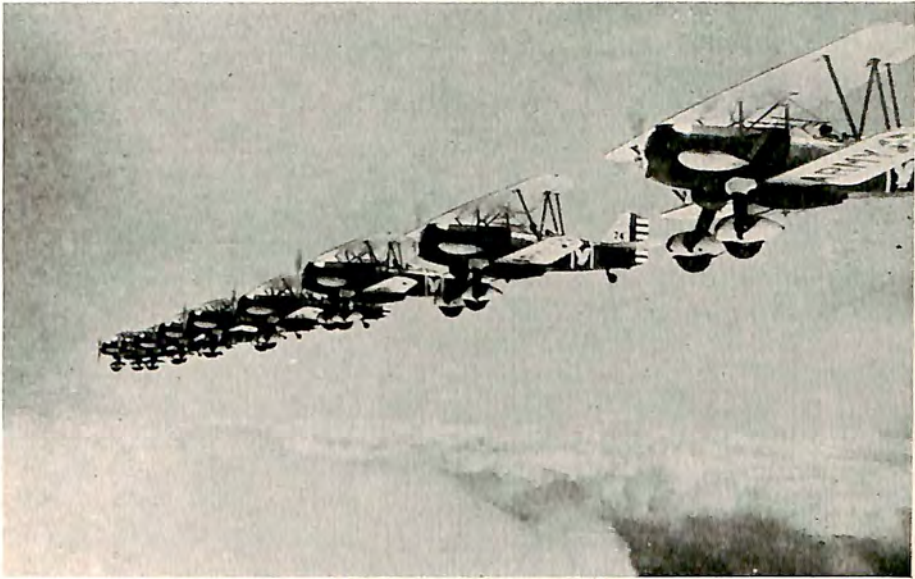

HAWKS FROM SELFRIDGE

Conqueror-powered Curtiss Hawk pursuits of the 17th Pursuit Squadron in formation flight above clouds.



TERROR OF THE SKIES

First of 12 new Conqueror-powered Curtiss Shrike attack planes undergoing service tests in Texas.

tional outlets for the products of American aircraft manufacturers. The world-wide interest that had developed in the efficiency and operations of the American military and air transport services brought orders from many countries in South America, Canada, Europe and Asia. The importance of this export market is discussed in an early chapter, and details of American aircraft being operated in foreign countries will be found in the chapter devoted to "World Aviation in 1932."

There were few shifts in the corporate control of manufacturing units by the several major holding companies during 1932 such as were experienced between 1929 and 1931. The Aviation Corporation, with American Airways, Inc., as its principal operating subsidiary, retired from the manufacturing field late in 1932 by turning over the transport designs of its manufacturing subsidiary, American Airplane and Engine Corporation, to the General Aviation Manufacturing Corporation, a division of General Motors. Earlier in the year the Fairchild commercial models produced by American Airplane and Engine Corporation had been taken over by the Fairchild Aviation Corporation and continued in production by its manufacturing division, the Kreider-Reisner Aircraft Company.

The Cord Corporation continued the operation of its aircraft manufacturing unit, the Stinson Aircraft Corporation, and its aircraft engine unit, the Lycoming Manufacturing Company. The Curtiss-Wright Corporation concentrated its aircraft and engine manufacturing in three units: The Curtiss Aeroplane and Motor Company, devoted to military aircraft engineering and production at Buffalo, N. Y.; the Curtiss-Wright Airplane Company, devoted to commercial aircraft production and military planes for export; and the Wright Aeronautical Corporation, producing both the Wright and Curtiss engine lines for military and commercial markets. The Keystone Aircraft Corporation at Bristol, Pa., a fourth unit operated during 1932 in the production of flying boats and amphibians, was absorbed as a part of the Buffalo plant late in the year.

United Aircraft and Transport Corporation continued operation of its six manufacturing units in accord with a plan carried out late in 1931: the Boeing Airplane Company at Seattle, Wash., concentrating on heavy commercial transport and military fighters and bombers; the Sikorsky Aviation Corporation at Bridgeport, Conn., devoted to amphibion production; the Stearman Aircraft Company at Wichita, Kan., in the commercial field; the Chance Vought Corporation at Hartford, Conn., specializing on Navy observation planes; the Pratt and Whitney Aircraft Company, producing aircraft engines for both military and commercial markets; and the Hamilton Standard Propeller Company, devoted to propeller production. The last three units named were located in modern plants adjacent to each other on Rentschler Field, a United airport at Hartford.

In this chapter we have considered the major trends in aircraft design

as seen through the eyes of a score of leading aeronautical engineers who contributed their views to the composite picture, and have indicated something of the character of the market and the principal manufacturers who offered products to it. The carefully prepared specification and performance tables which immediately follow this chapter keyed to the several score three-view drawings of the most interesting new models for 1933 or those in production in 1932, provide a graphic picture of the progress made in the manufacturing field. The performance data presented have been guaranteed by the manufacturers within five per cent. of the figures listed. It



NEW LOW-WING PURSUIT

Representing a distinct departure in pursuit design, the new Wasp-powered Boeing pursuit is all-metal, low-wing.

should be interesting, too, to get a glimpse of the activity in the major manufacturing plants. While necessarily brief, the following résumés of the best known establishments, scattered throughout the country, are designed to provide a general picture of the range of activities and the types of products offered. Manufacturers are listed alphabetically for convenience in future reference.

Aeronautical Corporation of America of Cincinnati, O., concentrated on the production of the Aeronca C-3, a light two-place, side-by-side monoplane powered with an Aeronca E-113A engine. The new model, evolved from the open cockpit type known as the Collegian, was modified to afford protection to its occupants by the addition of a two-door cabin.

American Airplane and Engine Corporation, a division of the Aviation Corporation, completed a production order of the Pilgrim 100-A (Pratt and Whitney Hornet), a ten-place cabin transport monoplane, designed especially for American Airways, Inc., the operating subsidiary of the Aviation Corporation. Experimental work also was carried forward at the Farmingdale, N. Y., plant on a new low-wing metal transport, but this design was turned over to General Aviation Manufacturing Corporation late in 1932 when American Airplane and Engine Corporation withdrew from the manufacturing field.

Amphibions, Inc., of Garden City, N. Y., supplemented its Privateer P-3, a three-place cabin monoplane amphibion powered with a Continental A-70 or Wright Whirlwind engine mounted as a pusher, by addition of a new model, the Privateer P-3B (Continental R-690). The new model differed from its predecessor in that its hull width was increased and a shock absorber landing gear added.

B/J Aircraft Corporation of Baltimore, Md., a division of North American Aviation, Inc., continued to confine its manufacturing activities to military production and experimental designs for the Army and Navy. A production order of a new two-seater pursuit, known as the YIP-16 (Curtiss Conqueror), was completed in 1932 for the Army. Work on a production order of OJ-2 (Pratt and Whitney Wasp Jr.) observation planes for the Navy was under way at the close of the year. Other work for the Navy included modification of the XFJ-2 (Pratt and Whitney Wasp) single-seater fighter, equipping an OJ-2 with Zap flaps, and experimental work on a new two-seater fighter and a single-seat fighter. The company made a substantial increase in its personnel during 1932.

Bellanca Aircraft Corporation of New Castle, Del., continued to improve its three basic models increasing their performance, as can be seen from the following tables of data. The Pacemaker and Skyrocket models were modified so that engines of greater horsepower could be installed and the gross weight of both models increased to 4,900 pounds. The Airbus, a 12 or 15 place cabin transport monoplane, was powered with a single Pratt and Whitney Hornet, Wright Cyclone or Curtiss Conqueror engine. The Skyrocket, a six-place cabin monoplane, was powered with a Pratt and Whitney Wasp. The Pacemaker, a six-place cabin monoplane, was available with a Packard Diesel, Pratt and Whitney Wasp Jr., or Wright Whirlwind 300 engine. All models were adaptable to float equipment. Contracts were filled during the year for both the Army and Navy as well as for export.

Boeing Airplane Company of Seattle, Wash., a division of United Aircraft and Transport Corporation, was busily engaged in the production of fighters for the Army and Navy, bombers for the Army, and a new commercial transport. Sixty new high speed transports, the Boeing 247

(2 Pratt and Whitney Wasps), were under production for United Air Lines with the first scheduled for delivery early in 1933. It was an all-metal low-wing twin-engined transport designed for a top speed of 175 miles an hour and cruising speed of 155 miles an hour with a full load of ten passengers, two pilots and 400 pounds of mail. Many of the features of the Boeing Monomail, introduced in 1930, and the Boeing Y1B-9A bomber were incorporated in the new design, such as its retractable landing gear, engine nacelles faired into the wing, and special trailing rudder and elevator flaps for trimming. Comfort and high speed were primary con-



NEW TWO-SEATER PURSUIT

Army's new B/J P-16 (Curtiss Conqueror) pursuit plane designed to meet changing tactical plans.

siderations. Principal specifications and a three-view drawing of the design will be found at the end of this chapter. Five new Army bombers, the Boeing Y1B-9A (2 Pratt and Whitney Hornets) of all-metal low-wing semi-monocoque construction, were delivered in 1932. Three new low-wing all-metal pursuits, known experimentally as the XP-936 and later designated as the Boeing P-26 (Pratt and Whitney Wasp), were delivered for service tests. Earlier in the year, 185 single-seater pursuits of the P-12E and P-12F (Pratt and Whitney Wasps) series were produced for the Army. Concurrently, 21 single-seater F4B-3 (Pratt and Whitney Wasp) fighters were completed for the Navy. Production was started late in the year on an order for 54 single-seater F4B-4 (Pratt and Whitney Wasp) fighters

for the Navy. Commercial deliveries included the Boeing 40B-4 (Pratt and Whitney Hornet) biplane for mail and passengers and the Boeing 100-F, a commercial version of the P-12F design. Employment in the Seattle factory reached its peak with 1,300 men at work.

Brazil Aircraft Corporation of Brazil, Ind., manufactured a two-place open cockpit monoplane powered with either a Szekeley 55 horsepower engine or an Aeromarine 50 horsepower engine.

Consolidated Aircraft Corporation of Buffalo, N. Y., started delivery on an order for the Navy of 23 patrol flying boats known as the XP₂Y-1, the largest flying boat yet to enter the naval service. It was of all-metal construction except for fabric wing covering and was powered with three Wright Cyclone engines of 600 horsepower each. The Fleetster was produced in two models as an air line transport, first as a ten-place high-wing metal monoplane with a Wright Cyclone and then as an eight-place parasol wing monoplane with a Pratt and Whitney Hornet engine.

Curtiss Aeroplane and Motor Company of Buffalo, N. Y., a division of the Curtiss-Wright Corporation, concentrated on military aircraft production, with nearly 1,000 persons employed. A new two-place all-metal observation sesquiplane, the YO-40 Raven (Wright Cyclone F) was developed for the Army with cockpit cabins and a retractable landing gear to give it a high speed in excess of 200 miles an hour. Production of five of them was under way late in the year for Army service tests. Thirteen Curtiss YA-8 Shrike (Curtiss Conqueror) low-wing all-metal attack monoplanes, equipped with slots and flaps, were delivered to the Army for service tests. Delivery to the Army of 46 Curtiss P-6E Hawk (Curtiss Conqueror) pursuit planes was completed, and the Hawk further developed into the F11C-1 and F11C-2 (Wright Cyclone) shipboard fighters for the Navy. Twenty-eight of the latter model were in production at the close of 1932. Seven single-place fighters known as the F9C-2 (Wright Whirlwind) model were delivered to the Navy with equipment to enable them to make carrier landings and contacts with the "U.S.S. Akron" in flight. Five of them were housed in the hull of the "Akron." A new low-wing all-metal pursuit, the XP-934 (Curtiss Conqueror), with automatic slots and flaps, was delivered to the Army Air Corps late in the year for test. Forty-one Curtiss Hawk (Wright Cyclone) pursuits, six equipped with floats, were sold to foreign governments, chiefly to Turkey and South American governments. Extensive service tests were carried on throughout the year on the Curtiss electric controllable pitch propeller by the Army, Navy and Curtiss Company with notable results.

Curtiss-Wright Airplane Company of St. Louis, Mo., also a division of the Curtiss-Wright Corporation, devoted its attention to the commercial and foreign military markets. Its outstanding development was the design for delivery in 1933 of the Curtiss T-32 Condor (2 Wright Cyclones),

a new biplane transport designed to carry 15 passengers, 2 pilots, complete radio, and 650 pounds of mail, express and baggage at a cruising speed of 140 miles an hour. High speed with maximum passenger comfort was the goal of its designers. Six of the new transports were scheduled for delivery in 1933 to Transamerican Airlines Corporation, with an order for five from Eastern Air Transport. Four new commercial models were introduced during the National Aircraft Show in April, including the Curtiss-Wright Sport (Wright Whirlwind 175), Curtiss-Wright Speedwing (Wright Whirlwind 250) and Curtiss-Wright Special Speedwing (Wright



TEXACO'S SKY CHIEF

Lieut. Comdr. Frank M. Hawks takes to the skyways again in his new 14 cylinder Wright Whirlwind Northrop monoplane.

Whirlwind 330), all three-place open biplanes; and the Curtiss-Wright Special Speedwing De Luxe (Wright Whirlwind 420), a two-place open biplane. Production was continued on the Curtiss-Wright Sedan (Wright Whirlwind 250), a four-place cabin monoplane, and a six-place cabin monoplane powered with a Wright Whirlwind 300. Two Curtiss-Wright Kingbirds (2 Wright Whirlwind 300) eight-place cabin monoplanes were produced and shipped to Turkey as initial equipment on the first Turkish air line. Entering the military market for the first time, the company developed the Curtiss-Wright Osprey (Wright Whirlwind 420) as a two-seater attack, pursuit and observation plane for export. Ninety employees were added

late in 1932 to the 200 normally employed to aid in speeding up work on Ospreys to fill orders placed by South American governments.

Davis Aircraft Corporation of Richmond, Ind., continued production of its two-place open monoplane powered with either Warner or Kinner engines.

Douglas Aircraft Company of Santa Monica, Cal., for years manufacturers solely of military aircraft, continued to branch out in the commercial field and at the same time keep up its military production. Late in 1932, its designers were busy on a new model air line transport to meet the specifications of a transcontinental operator. Production of its twin-engined cabin monoplane amphibian, the Dolphin (2 Pratt and Whitney Wasps), was continued for the commercial market. For the military market, the O-38S was introduced as a new model in its O-38 Army two-place observation plane series, and a new experimental Army observation plane, the YO-31 (Curtiss Conqueror) was developed.

Ford Motor Company of Dearborn, Mich., continued to offer its 5-D (3 Pratt and Whitney Wasps) 16-place transport for air line operation and developed a new design super-transport, the 14-A (3 Hispano Suizas), plans for production of which were dropped late in 1932. The new experimental model had a span of 110 feet, was 80 feet long, and had seats for 36 passengers.

General Aviation Manufacturing Corporation of Dundalk, Md., a subsidiary of General Motors, completed production of five FLB flying boats for the United States Coast Guard, powered with two Pratt and Whitney Wasps. They were christened: "Antares," "Altair," "Acrux," "Acomar," and "Arcturus." A contract for 12 twin-engined Army observation planes known as the YO-27 was being completed at the close of the year for the Army Air Corps. Development also was being carried forward on a low-wing all-metal monoplane designed for transport use.

Great Lakes Aircraft Corporation of Cleveland, O., continued production of its two-place open biplanes, the 2T-1A (Upright A.C.E.) and 2T-1E (Hi-Drive A.C.E.). For the Navy, a production contract of its three-purpose (torpedo, bombing and observation) TG-2 model was completed for the Navy along with an experimental observation amphibian biplane. The design of a dive bomber was completed late in the year and construction begun.

Hall-Aluminum Aircraft Corporation of Buffalo, N. Y., continued experimental work for the Navy. The company also produced aluminum alloy drawn sections and other aluminum parts for other manufacturers.

Kellett Autogiro Corporation of Philadelphia, Pa., concentrated its activities on production of the Kellett K-3 (Kinner) autogiro, a two-place side-by-side design for private ownership. The model was offered with both open and cabin type cockpits.

Keystone Aircraft Corporation of Bristol, Pa., a division of the Curtiss-Wright Corporation, completed a production order of 63 Army bombers of the B-5A (2 Pratt and Whitney Hornets) and B-6A (2 Wright Cyclones) types. For the Navy, a production order of PK-1 (2 Wright Cyclones) patrol boats was completed. Late in the year a new observation amphibian was completed for the Navy along with an order for two-place observation amphibians of the OL-9 (Pratt and Whitney Wasp) type. For the commercial market, the Air Yacht K-85 (Wright Cyclone), an eight-place amphibian, and the Commuter (Wright Whirlwind 300), a four-place



ROUGH SEA TAKE-OFF

New B/J OJ-2 Navy seaplane, powered with a Wasp Junior engine, taking off in its rough water test.

amphibian, were offered. Personnel from the Keystone plant was transferred to the Curtiss Aeroplane and Motor Company at Buffalo late in the year to continue development work there.

Kreider-Reisner Aircraft Company, Inc., a division of Fairchild Aviation Corporation at Hagerstown, Md., continued production of the Fairchild 22, a two-place open monoplane powered with either Cirrus or Menasco engines, and introduced a new model designated as the Fairchild 24, a three-place cabin monoplane powered with Cirrus, Warner or Menasco engines.

Lockheed Aircraft Corporation of Burbank, Cal., was reorganized during 1932 to continue the production of the various Lockheed models,

including the Orion, Altair and Vega. In addition, a low-wing all-metal monoplane was being designed for the air line transport field.

Grover Loening Aircraft Company, Inc., of Garden City, N. Y., continued development of an amphibian plane to be carried aboard submarines for the Navy and worked on a design for a Navy scouting plane.

The Glenn L. Martin Company of Baltimore, Md., which for many years confined its activities to the military market, indicated a branching out in the commercial field with the announcement late in 1932 of a contract by Pan American Airways for a giant flying boat to carry 50 passengers over long water jumps. During 1932, the company completed a production order for 32 dive bombers of the BM-1 and BM-2 type for the Navy. Two series of rough water tests were completed without incident on the XP₂M-1 Navy patrol flying boat, one with three engines and one as a twin-engined airplane. A twin-engined monoplane bomber, the XB-907 (2 Wright Cyclone F), with bomb capacity of 1,200 to 2,500 pounds and performance similar to the best standard pursuit types, was delivered to the Army Air Corps for tests in October. A completely enclosed transparent turret provided the forward guns an effectiveness never attained before in fast airplanes. Its wing and fuselage construction were entirely new, the latter being of "restrained shell" construction which provided extreme strength and rigidity with approximately half the weight of the usual monocoque type. The big bomber was equipped with a retractable landing gear.

Monocoupe Corporation of Robertson, Mo., continued production of a two-place cabin monoplane powered with Lambert and Warner engines.

Pitcairn Aircraft, Inc., of Willow Grove, Pa., early in 1932 introduced a new model autogiro, the PA-18 (Kinner 160), a two-place open cockpit type, to supplement its earlier models, the PCA-2, PCA-3 and PAA-1. The rotor area was increased over previous two-place models and improved control surfaces provided. Flight tests were conducted late in the year on a four-place cabin autogiro, the PA-19 (Wright Whirlwind 420).

Sikorsky Aviation Corporation of Bridgeport, Conn., a division of United Aircraft and Transport Corporation, completed its third giant amphibion-flying boat of the S-40 (4 Pratt and Whitney Hornets) type for Pan American Airways, equipped to carry 38 passengers and a crew. Late in the year, a new order was placed by Pan American Airways for an even larger flying boat to carry 50 passengers over long water jumps to be known as the S-43. The S-41, a 16-place cabin sesquiplane transport with two Pratt and Whitney Hornet engines, and the S-39 (Pratt and Whitney Wasp Jr.) and S-39C (Pratt and Whitney Wasp Jr. 400), both five-place cabin monoplane amphibions, were offered to the commercial market.

Stearman Aircraft Company of Wichita, Kan., a division of United Aircraft and Transport Corporation, continued production of its Senior Speedmail 4DM-1 (Wright Whirlwind 300), a single-place open biplane for mail transport. Late in the year, designs were carried forward on a new commercial model for 1933 called the Stearman Sportster. The C3R (Wright Whirlwind 240), a three-place open biplane, also was offered.

Stinson Aircraft Corporation of Wayne, Mich., a division of the Cord Corporation, introduced a new model air line transport, known as the Model U Airliner (3 Lycomings), an 11-place monoplane, with many refinements in design over the previous transport model, the T Airliner. It also supplemented its Model S, four-place cabin monoplane, with a new line in this field known as the Model R (Lycoming 215). Variations of this model were called the Model R2 with a Lycoming 240 horsepower engine and the Model R3, which had as its distinguishing feature a retractable landing gear.

St. Louis Aircraft Corporation of St. Louis, Mo., continued experimental designs in its Cardinal series of two-place cabin monoplanes.

Chance Vought Corporation of Hartford, Conn., a division of United Aircraft and Transport Corporation, concentrated its production on the basic Corsair two-place convertible biplane for the United States Navy. Seven modifications of this design were in production in 1932, including three types of the OU series and the O3U-3, an observation plane powered with a Pratt and Whitney Wasp, as well as the newest models, the V-65 and V-66. Experimental development of the Corsair with the new two-row Pratt and Whitney Wasp Jr., was carried on for the Navy. Designs were completed and work begun late in 1932 on a new high-speed two-place Navy fighter using the new two-row Pratt and Whitney Wasp engine.

The Waco Aircraft Company of Troy, O., introduced a new two-place side-by-side biplane with an easily removable coupe top known as the Model A and powered with either Kinner 100, 125 or 160, Warner Scarab, Jacobs or Continental engines. The four-place cabin biplane, Model C, was produced with Continental 165 or 210, Kinner 210, or Wright Whirlwind 165 engines. The Model F was continued in production with either Kinner 125 or Warner Scarab engines installed. The Model F2, a similar three-place open biplane, was offered with engines having power outputs ranging from 165 to 210 horsepower. The Company's export business in 1932 exceeded the four previous years and accounted for more than 25 per cent. of the total unit volume. Domestic sales in 1932 kept pace with the previous years' figures in units, and showed an increase in dollar volume. Specifications and performance data on the several models offered will be found in an appropriate table in the next section of this volume. A noteworthy feature of all Waco models was the efficient new landing gear, designed and patented by the company.

The designs reproduced in three-view drawings immediately following this chapter represent the most interesting models introduced or in production during the year. They have been arranged in several sections: Passenger and Mail Transports, Private Operation and Aerial Service and Military Airplanes, the designs of each manufacturer being listed alphabetically in each section. Specifications on the drawings, together with information given below each drawing and the performance and specification tables immediately following each section of commercial airplanes, will provide the engineer and layman alike with interesting data on each model. Sufficient information is given to permit simple computation of all data desired.

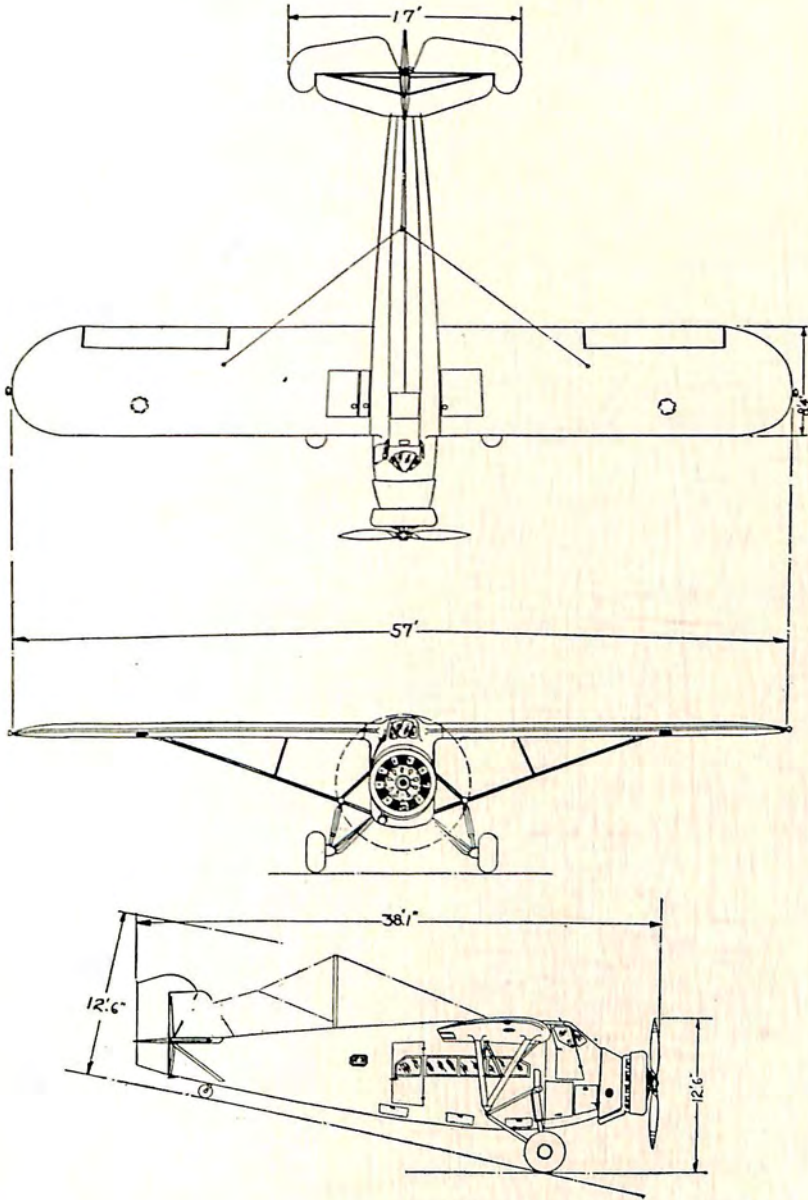

AMERICAN AIRPLANE & ENGINE CORPORATION
Farmingdale, L. I., N. Y.

PILGRIM 100-A — 10 PLACE
ENGINE: PRATT & WHITNEY HORNET

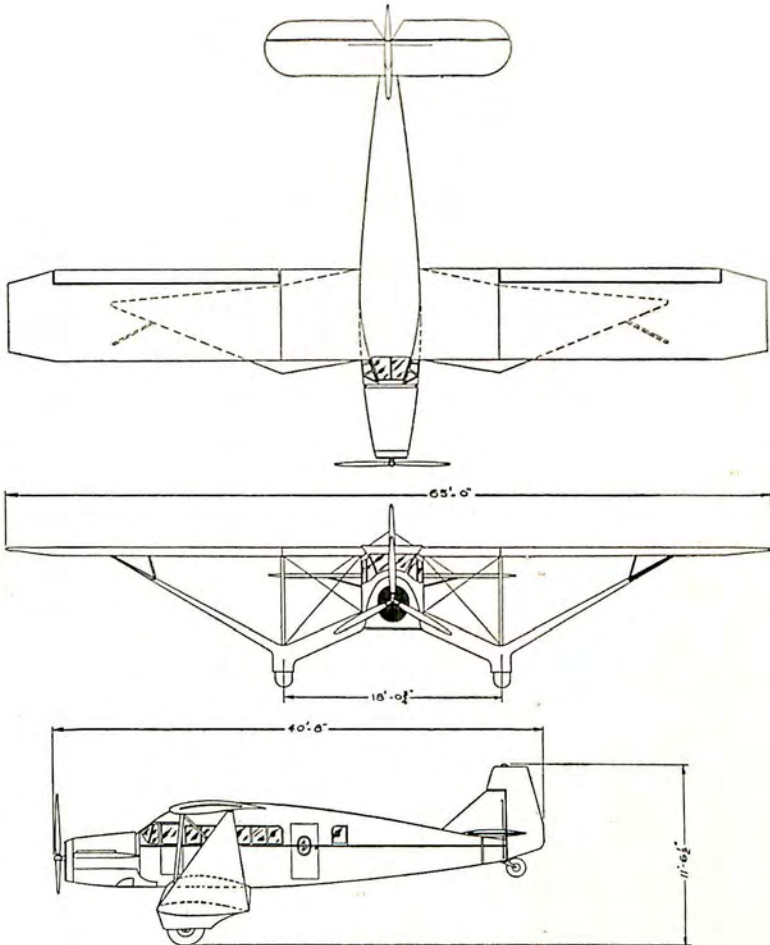

BELLANCA AIRCRAFT CORPORATION
New Castle, Del.

AIRBUS — 12-15 PLACE

ENGINE: CURTISS CONQUEROR
PRATT & WHITNEY HORNET
WRIGHT CYCLONE

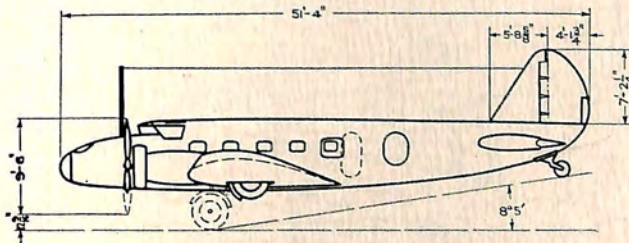
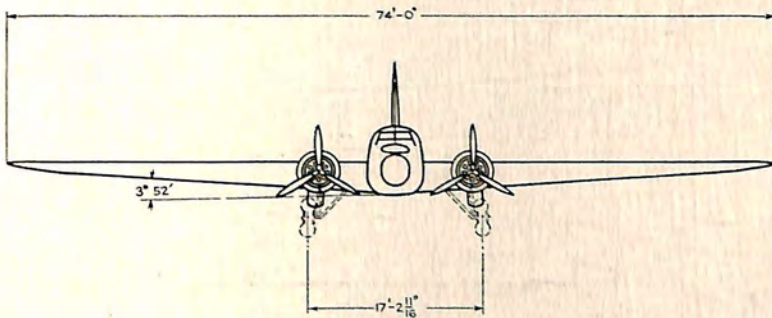
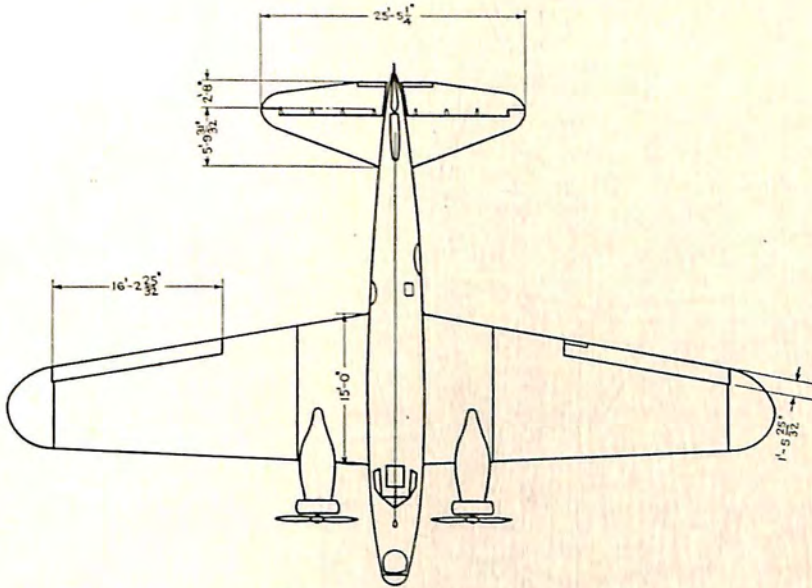

BOEING AIRPLANE COMPANY
 Seattle, Wash.
 MODEL 247 — 12 PLACE
 ENGINE: TWO PRATT & WHITNEY WASPS

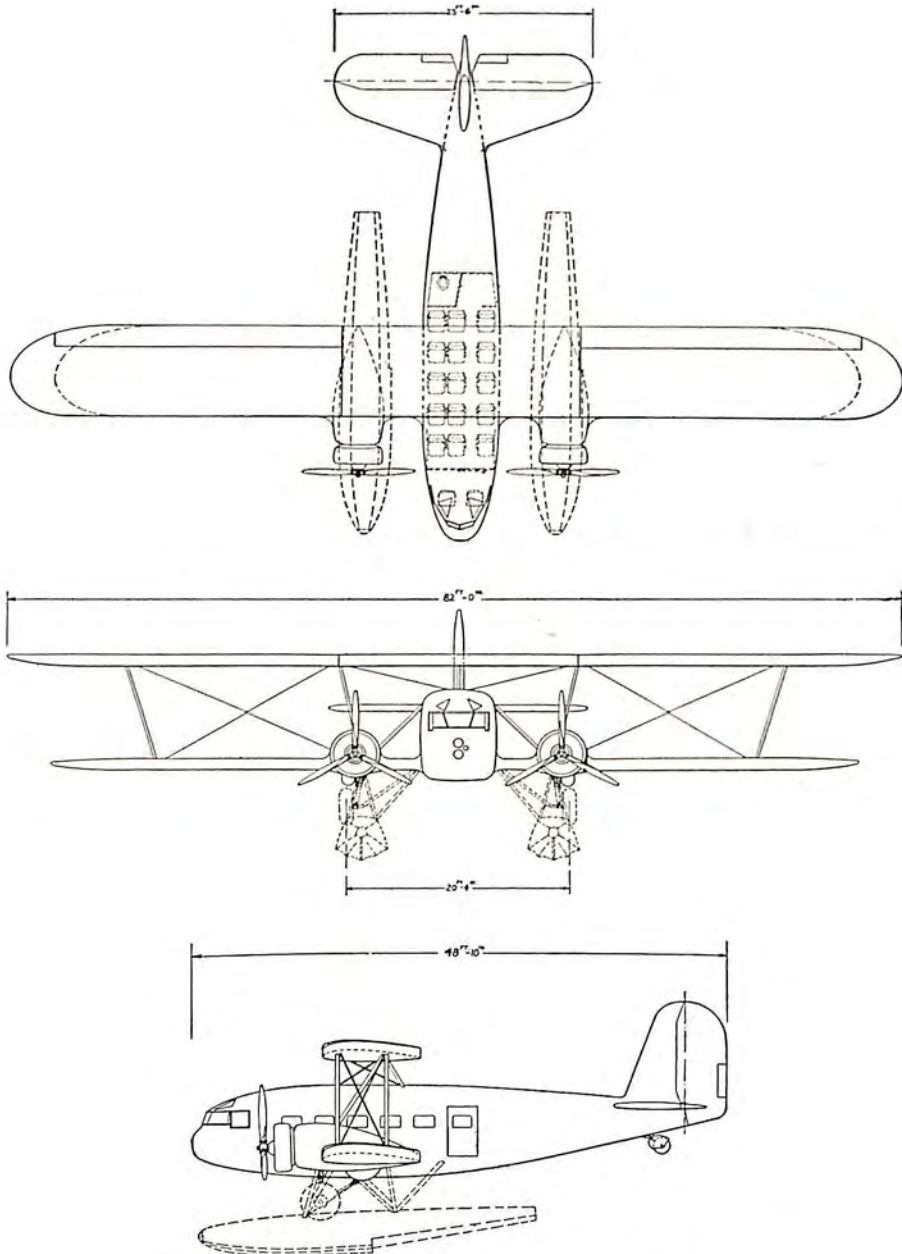

CURTISS-WRIGHT AIRPLANE COMPANY
St. Louis, Mo.

MODEL T-32 CONDOR — 17 PLACE
ENGINE: TWO GEARED WRIGHT CYCLONE F

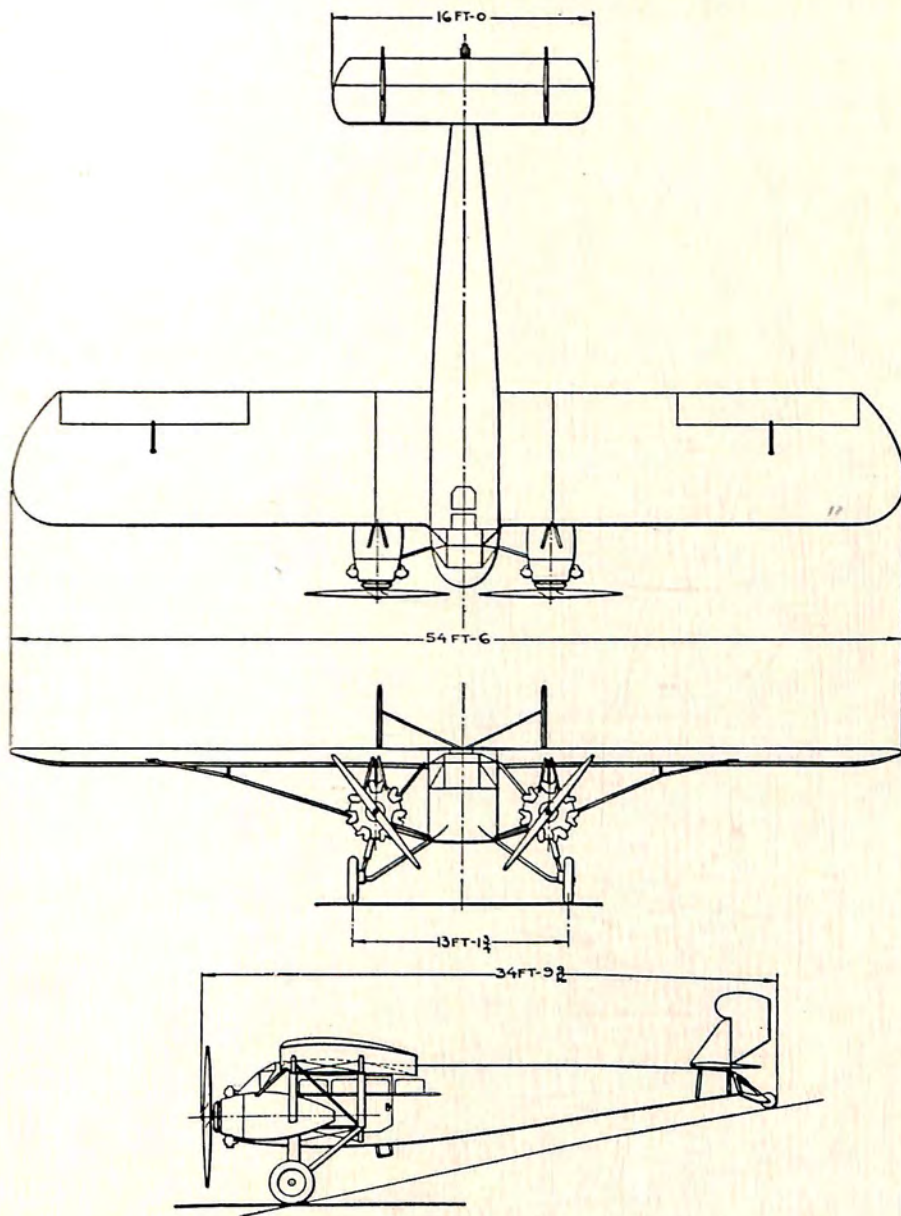

CURTISS-WRIGHT AIRPLANE COMPANY
St. Louis, Mo.

KING BIRD — 8 PLACE

ENGINE: TWO WRIGHT WHIRLWIND 300

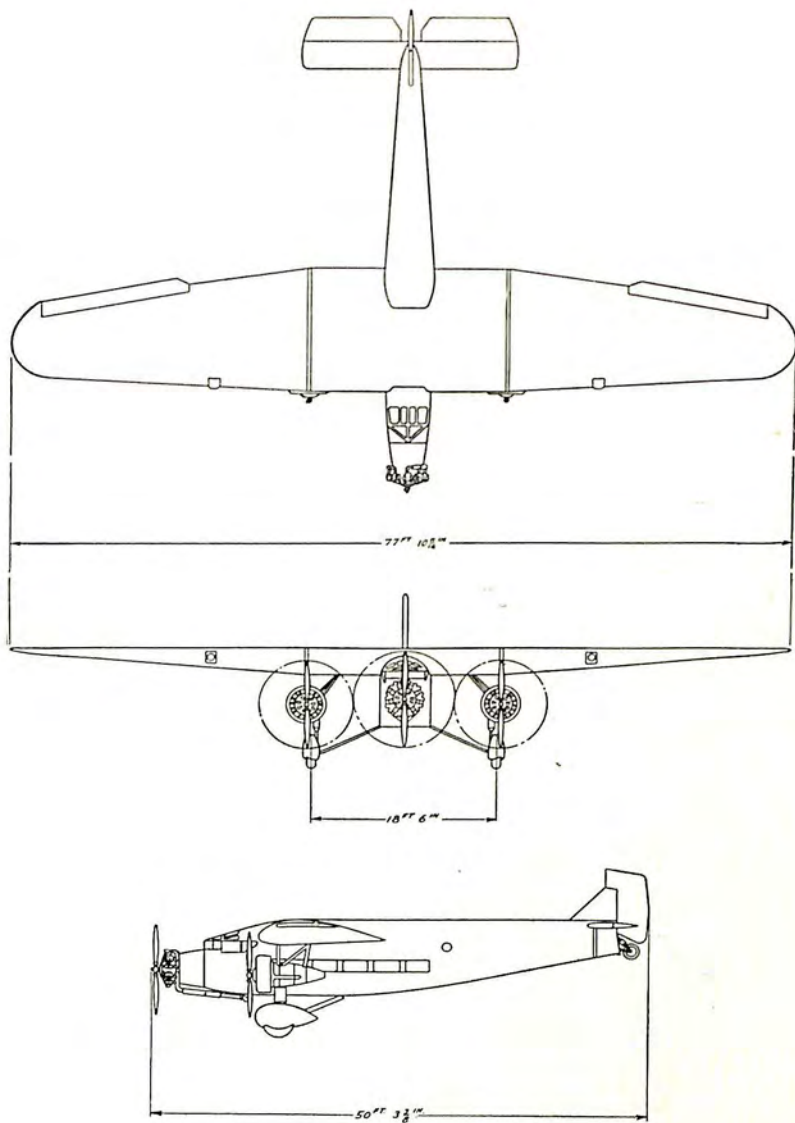

FORD MOTOR COMPANY
Metal Airplane Division
MODEL 5-D — 16 PLACE
ENGINE: THREE PRATT & WHITNEY WASPS

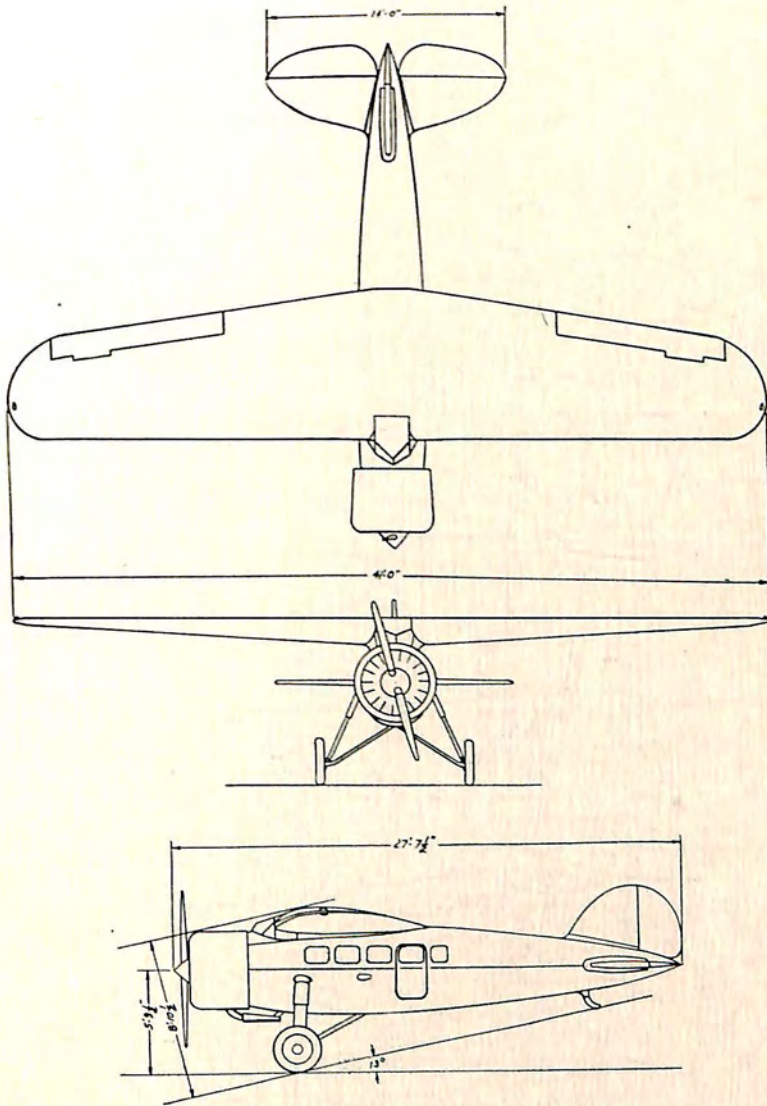

LOCKHEED AIRCRAFT CORPORATION
Burbank, Calif.

MODEL DL-1 — 7 PLACE
ENGINE: PRATT & WHITNEY WASP

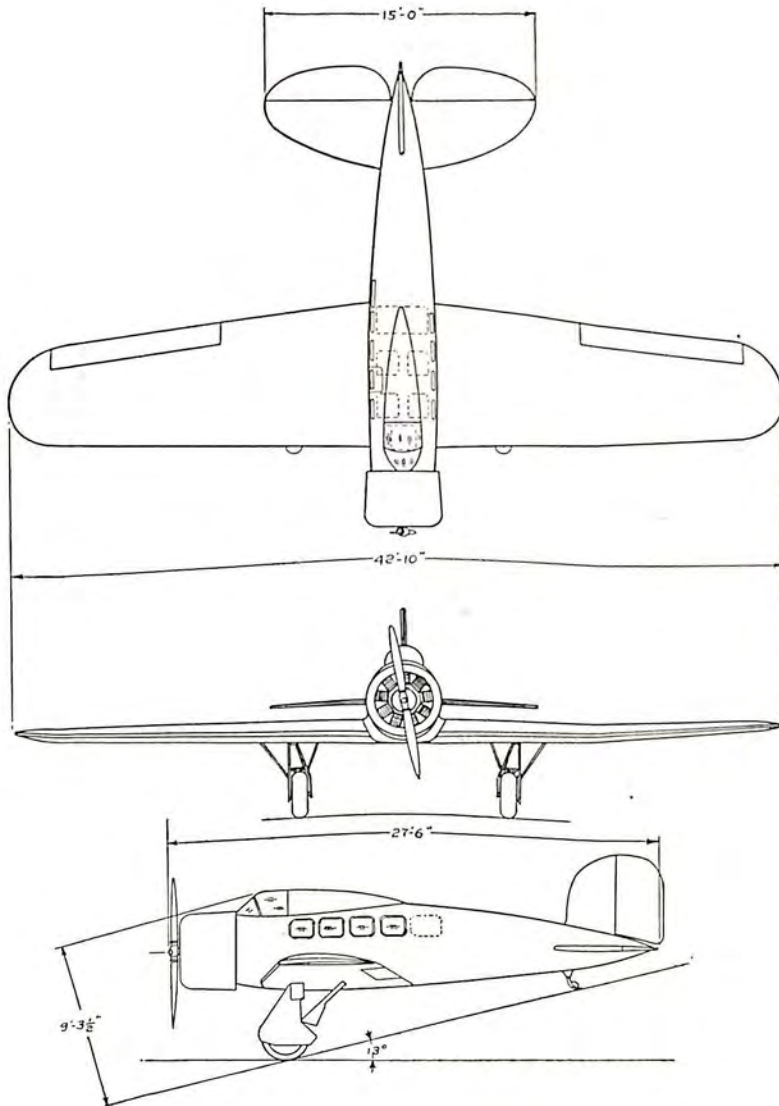

LOCKHEED AIRCRAFT CORPORATION
Burbank, Calif.

ORION — 7 PLACE

ENGINE: PRATT & WHITNEY WASP

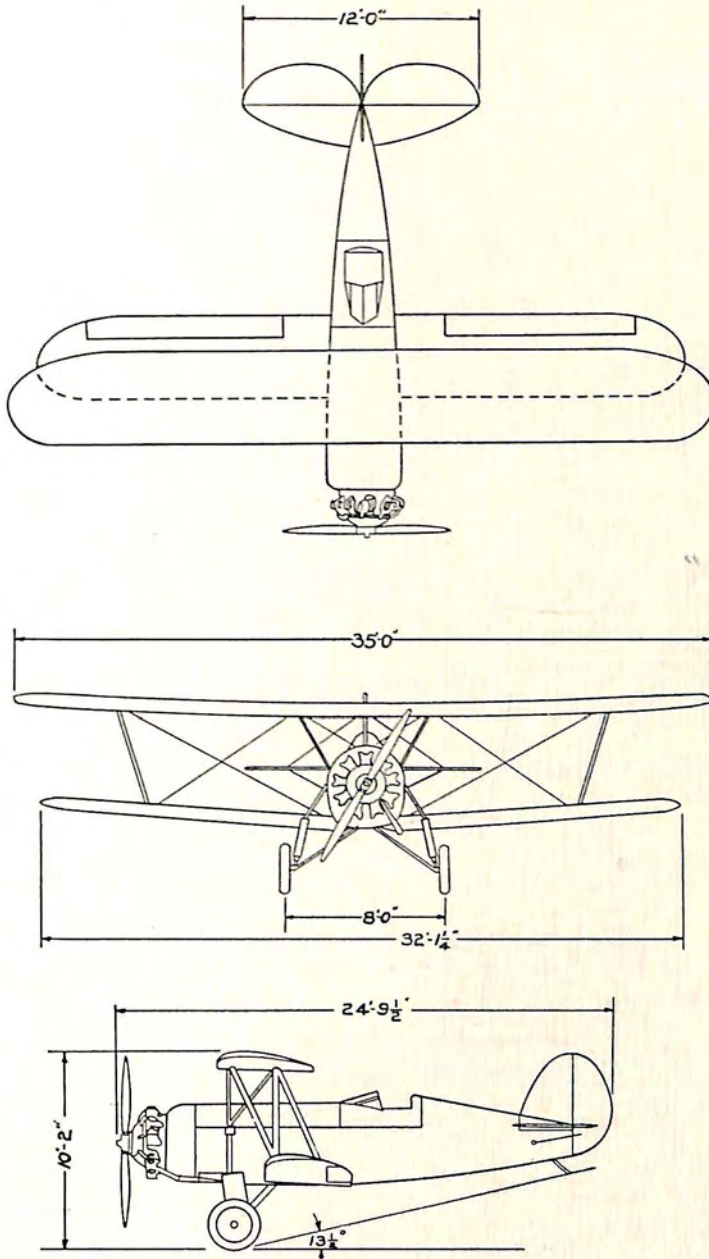

PITCAIRN AIRCRAFT, INCORPORATED
Willow Grove, Pa.

MODEL PA-8 — 1 PLACE
ENGINE: PRATT & WHITNEY WASP JR.
WRIGHT WHIRLWIND 300

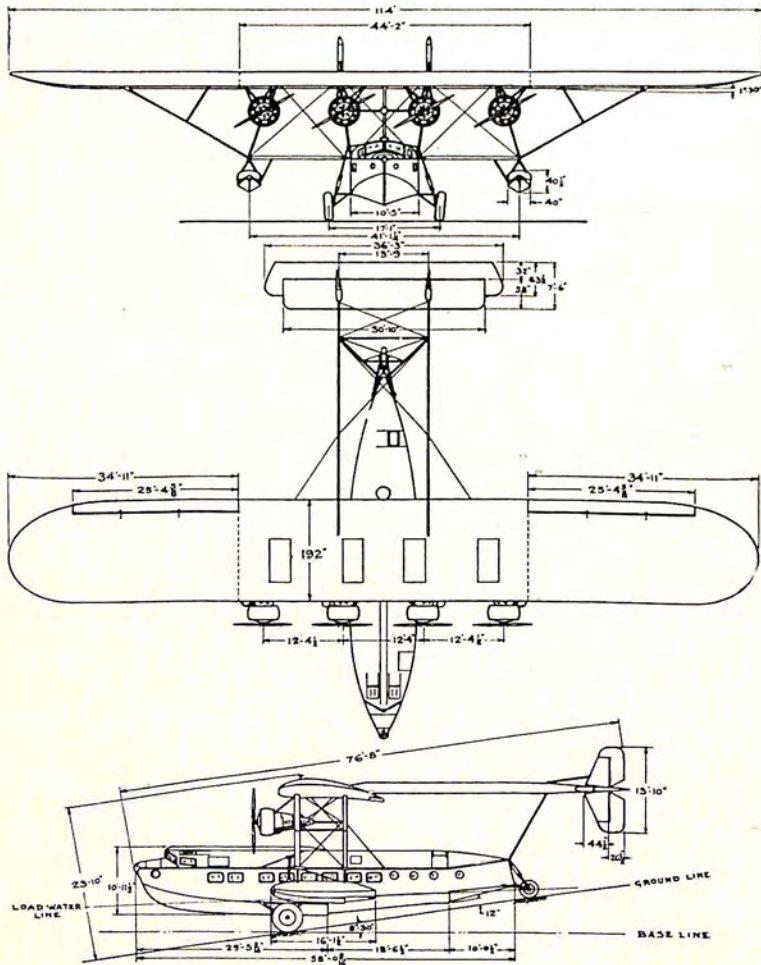

SIKORSKY AVIATION CORPORATION
 Bridgeport, Conn.
 AMPHIBION S-40 — 38 PLACE
 ENGINE: FOUR PRATT & WHITNEY HORNETS

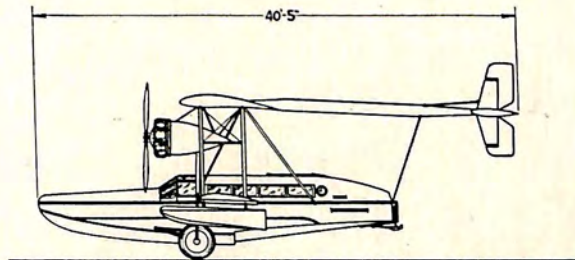
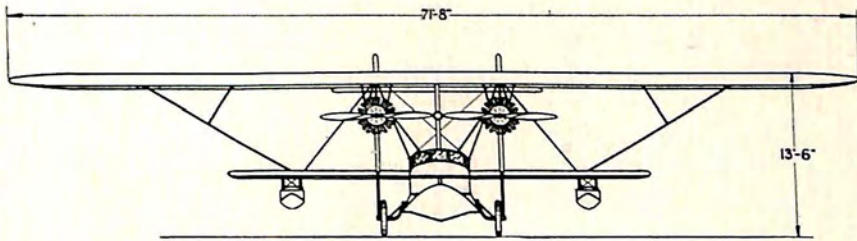
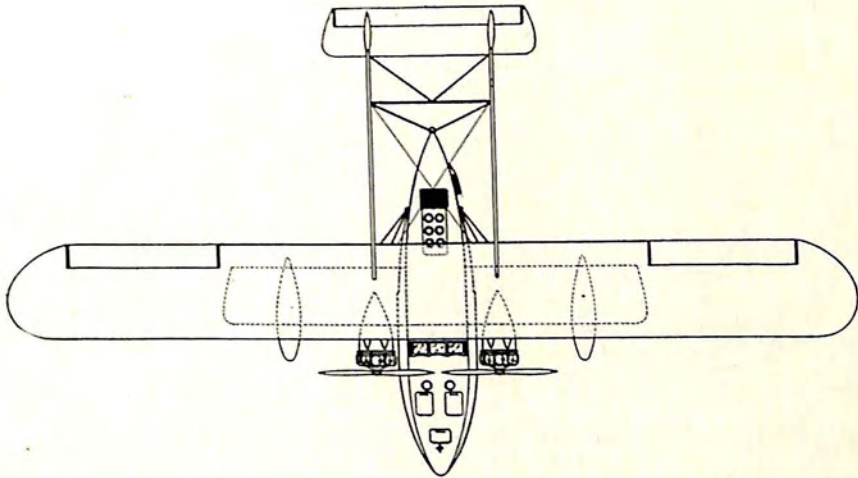

SIKORSKY AVIATION CORPORATION
Bridgeport, Conn.

AMPHIBION S-38 — 10-12 PLACE
ENGINE: TWO PRATT & WHITNEY WASPS

PASSENGER AND MAIL TRANSPORTS

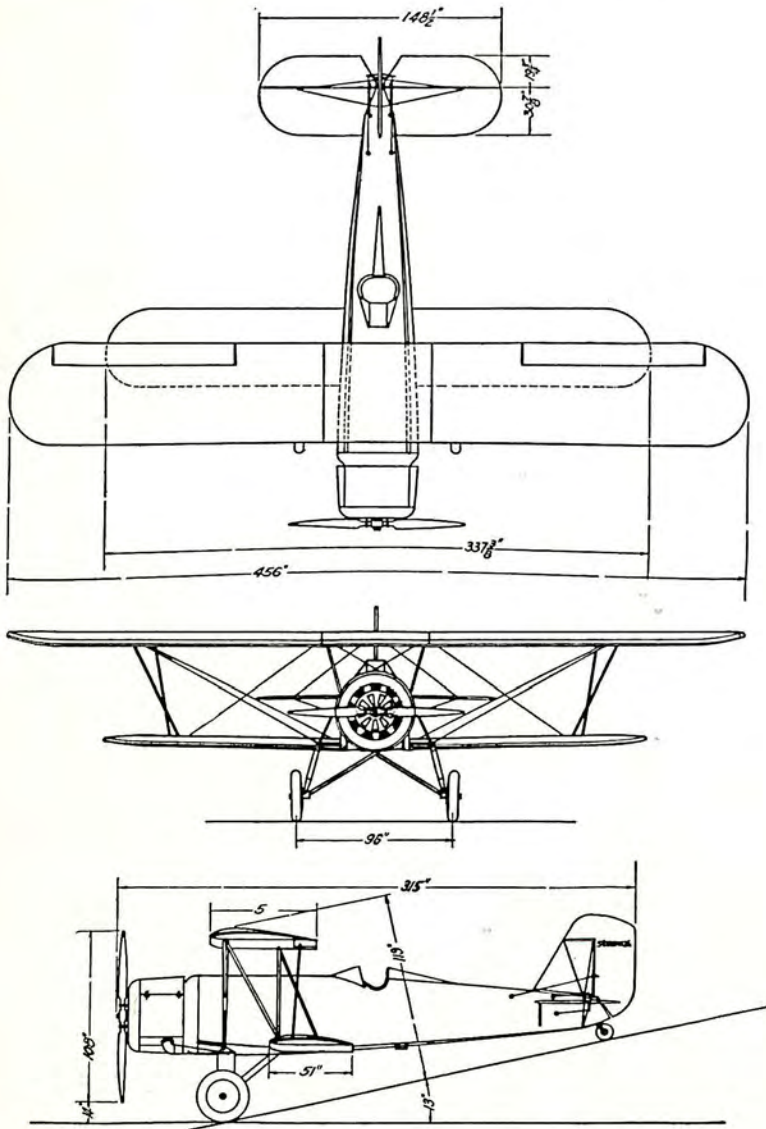

STEARMAN AIRCRAFT COMPANY
Wichita, Kan.

SPEEDMAIL — 1 PLACE

ENGINE: PRATT & WHITNEY WASP
PRATT & WHITNEY WASP, JR.
WRIGHT WHIRLWIND 300

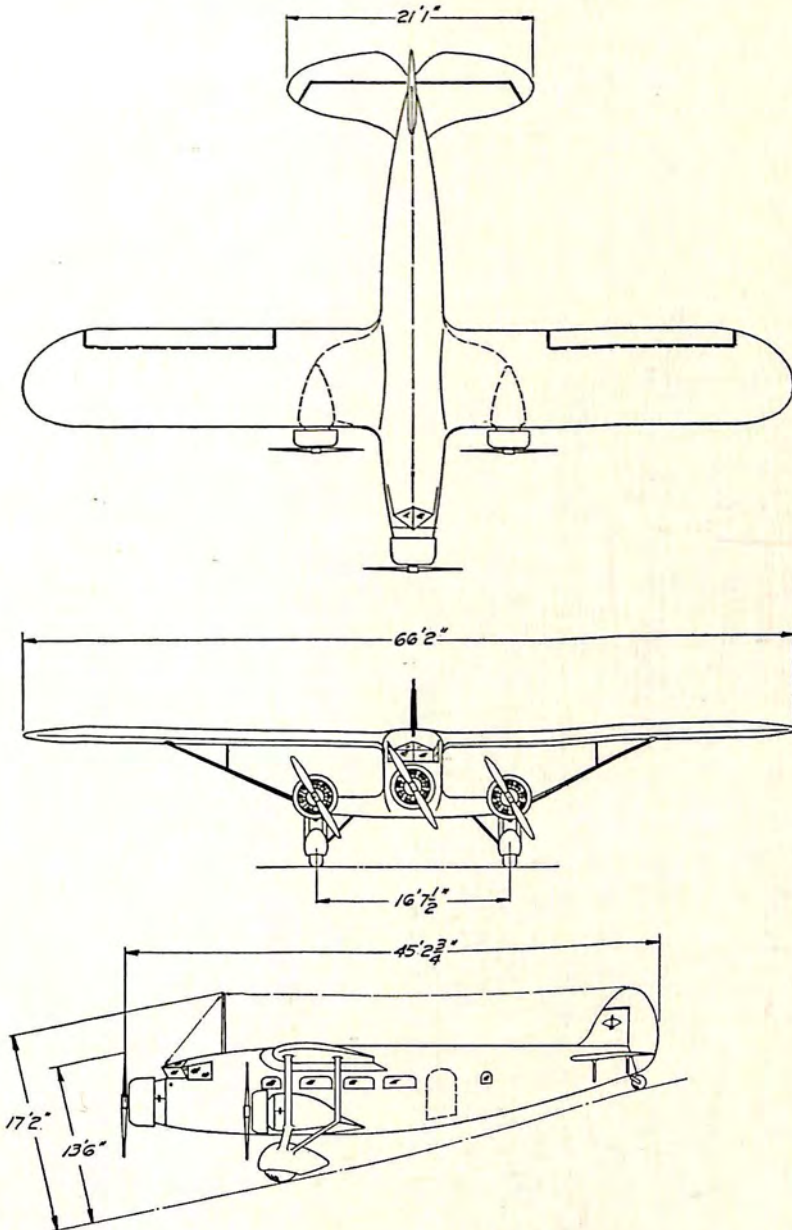

STINSON AIRCRAFT CORPORATION
Wayne, Mich.
MODEL U — 11 PLACE
ENGINE: THREE LYCOMINGS

PASSENGER AND MAIL TRANSPORTS

Name of Manufacturer	Model	Places	A.T.C. No.	Make of Engine	Total Rated H.P.	Wing Area Sq. Ft.	Gross Weight Lbs.	Pay Load Lbs.	High Speed M.P.H.	Cruising Speed M.P.H.	Stalling Speed M.P.H.	Service Ceiling Ft.	Cruising Radius Mi.
American Airplane.	Pilgrim 100-A	10	443	Pratt & Whitney Hornet	575	459	7,750	2,140	136	118	65	13,600	380
Bellanca Aircraft..	Airbus	12	391	Curtiss Conqueror	600	652	9,500	2,612	147	126	16,000	750
Bellanca Aircraft..	Airbus	12	391	Pratt & Whitney Hornet	575	652	9,590	2,985	139	120	13,000	750
Bellanca Aircraft..	Airbus	12	391	Wright Cyclone	575	652	9,590	2,985	139	120	13,000	750
Boeing Airplane...	247	12	2 Pratt & Whitney Wasps	1,100	836	12,210	2,400
Curtiss-Wright Airplane.....	Condor T-32	17	Pending	2 Geared Wright Cyc. F	1,300	1,208	16,100	3,200
Curtiss-Wright Airplane.....	King-Bird	8	348	2 Wright Whirlwind 300	600	405	6,360	1,400	135	115	65	16,200	420
Ford.....	5 D	16	409	3 Pratt & Whitney Wasps	1,260	835	13,500	3,840	150	120	64	18,500	600
Lockheed Aircraft.	D L-1	7	308	Pratt & Whitney Wasp	420	275	4,750	1,120	180	150	60	19,750	700
Lockheed Aircraft.	Orion	7	421	Pratt & Whitney Wasp	420	275	5,200	1,170	204	171	64	19,800	580
Pitcairn Aircraft...	P A-8	1	364	Pratt & Whitney Wasp, Jr.	300	278	4,000	1,000	150	120	58
Pitcairn Aircraft...	P A-8	1	364	Wright Whirlwind 300	300	278	4,000	1,000	150	120	58
Sikorsky Aviation..	Amphib. S-40	38	454	4 Pratt & Whitney Hornets	2,300	1,875	34,010	5,902	135	113	65	12,000	875
Sikorsky Aviation..	Amphib. S-38	10-12	126	2 Pratt & Whitney Hornets	840	720	10,480	2,000	125	110	55	18,000	600
Stearman Aircraft.	Jr. Speedmail	1	292	Pratt & Whitney Wasp	420	307	3,936	629	158	128	53	18,000	645
Stearman Aircraft.	Jr. Speedmail	1	305	Pratt & Whitney Wasp, Jr.	300	307	3,800	622	143	115	50	15,000	815
Stearman Aircraft.	Jr. Speedmail	1	304	Wright Whirlwind 300	300	307	3,800	663	145	118	50	15,000	835
Stinson Aircraft...	U	11	484	3 Lycomings	720	575	9,300	2,145	140	119	58	13,000	400

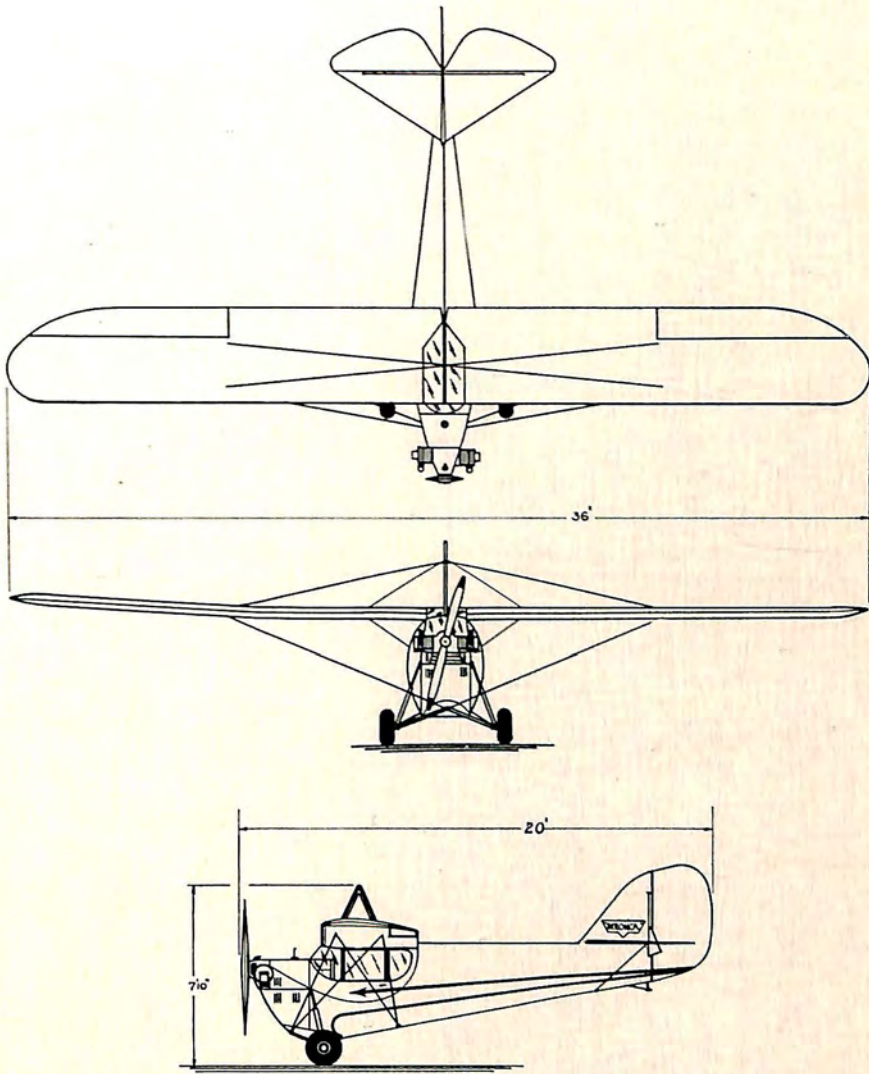

AERONAUTICAL CORPORATION OF AMERICA
Cincinnati, Ohio
AERONCA C-3 — 2 PLACE
ENGINE: AERONCA E-113A

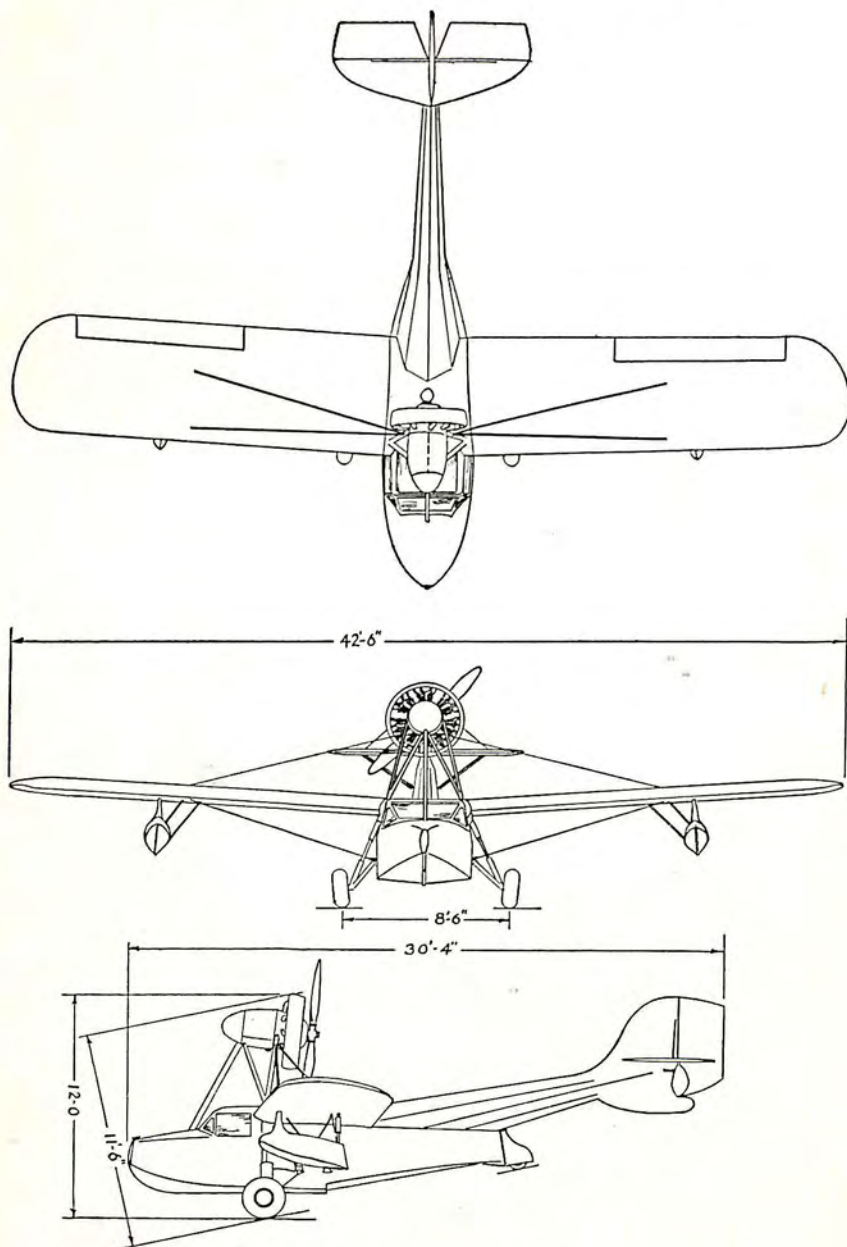

AMPHIBIONS, INCORPORATED
Garden City, L. I., N. Y.
PRIVATEER P-3B — 3 PLACE
ENGINE: CONTINENTAL R-690

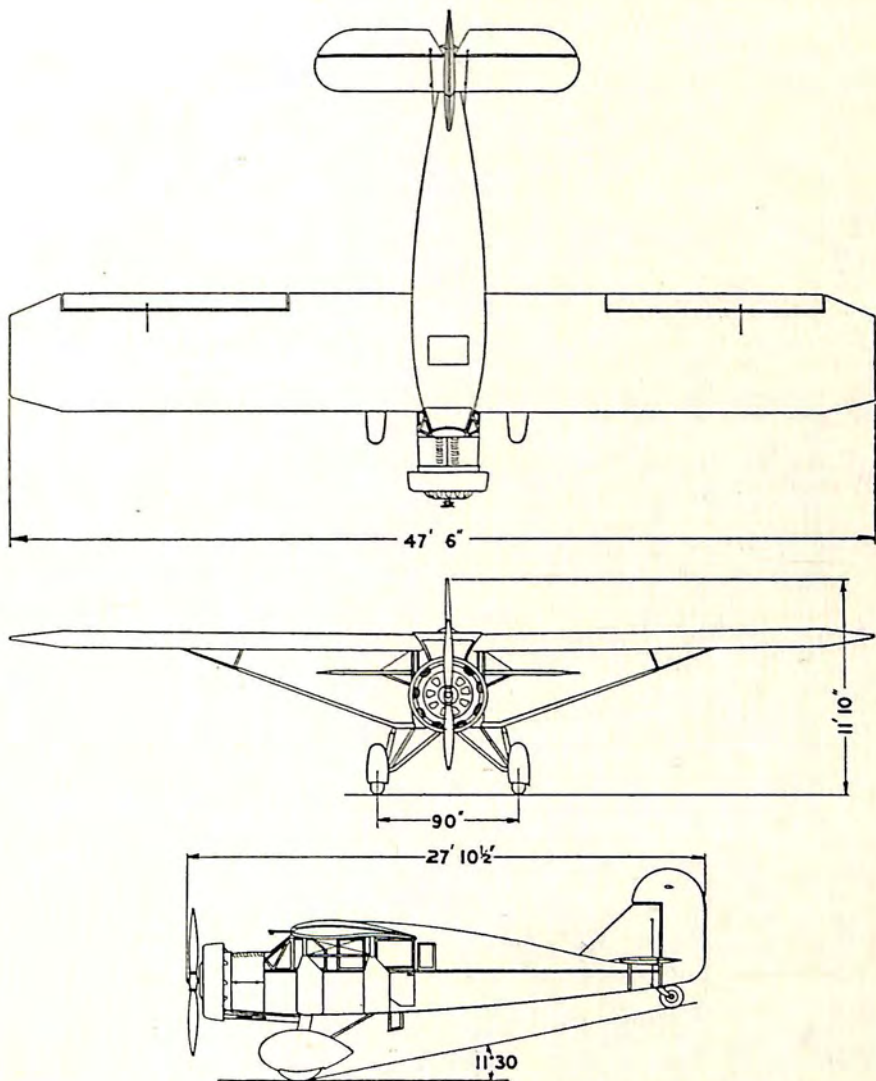

BELLANCA AIRCRAFT CORPORATION
 New Castle, Del.
 PACEMAKER — 6 PLACE
 ENGINE: PACKARD DIESEL
 PRATT & WHITNEY WASP, JR.
 WRIGHT WHIRLWIND 300

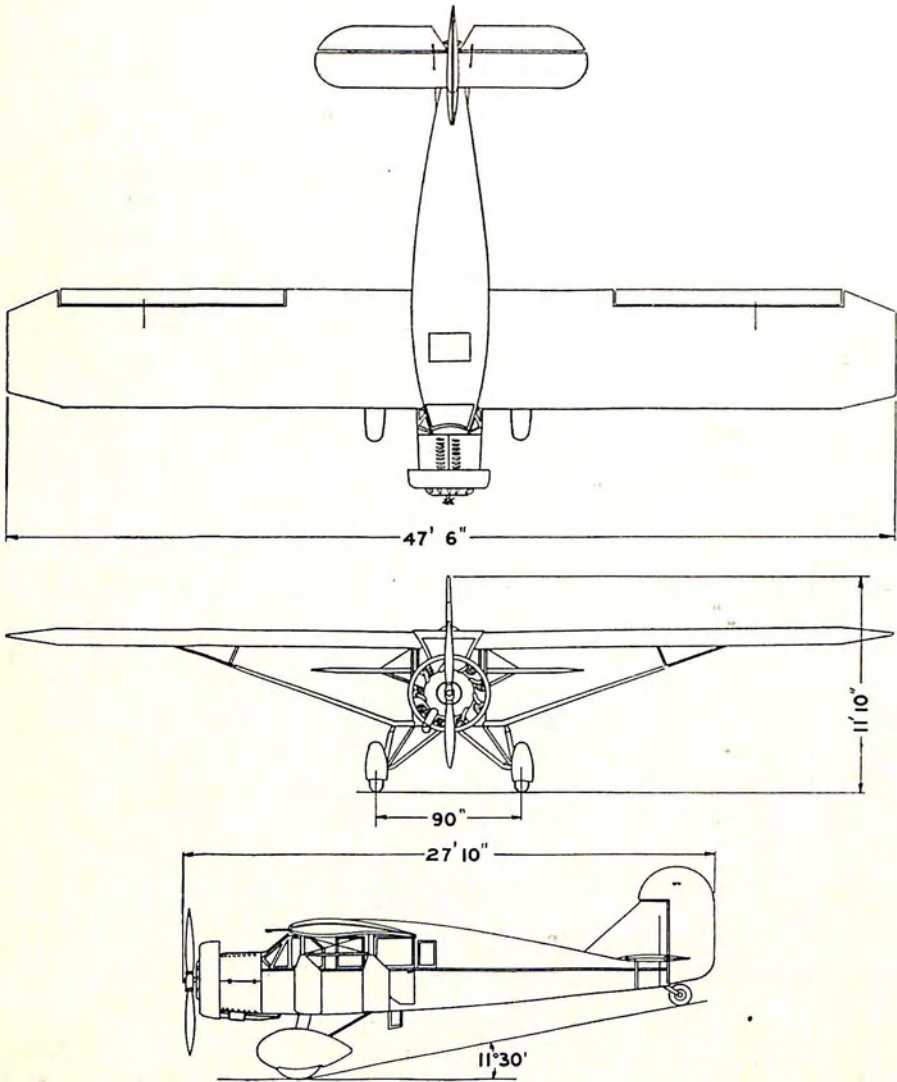

BELLANCA AIRCRAFT CORPORATION
New Castle, Del.

SKYROCKET — 6 PLACE
ENGINE: PRATT & WHITNEY WASP

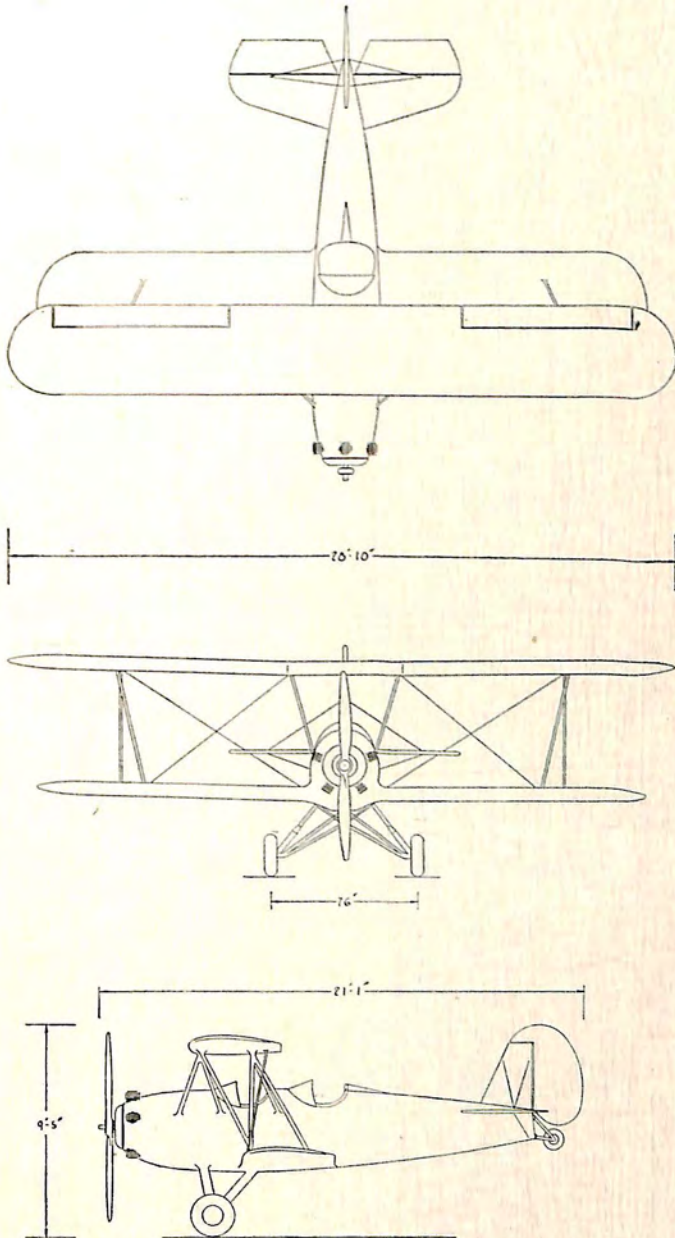

CURTISS-WRIGHT AIRPLANE COMPANY
St. Louis, Mo.

MODEL 16-E — 3 PLACE
ENGINE: WRIGHT WHIRLWIND 165

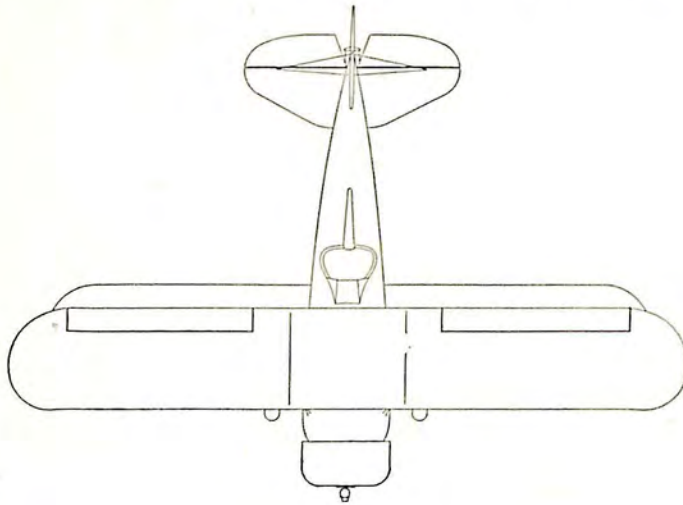

31' 0"

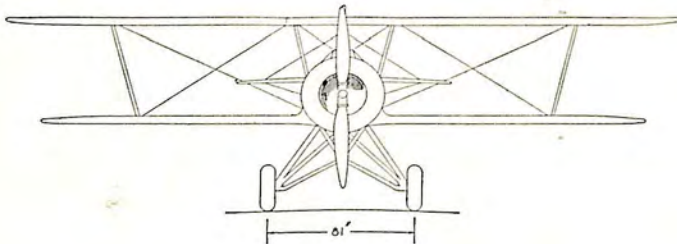

61"

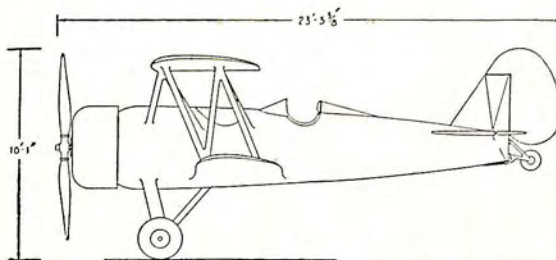

10' 1"

23' 5 1/8"

CURTISS-WRIGHT AIRPLANE COMPANY
St. Louis, Mo.

SPEEDWING — 2-3 PLACE

ENGINE: WRIGHT WHIRLWIND 240

WRIGHT WHIRLWIND 300

WRIGHT WHIRLWIND 420

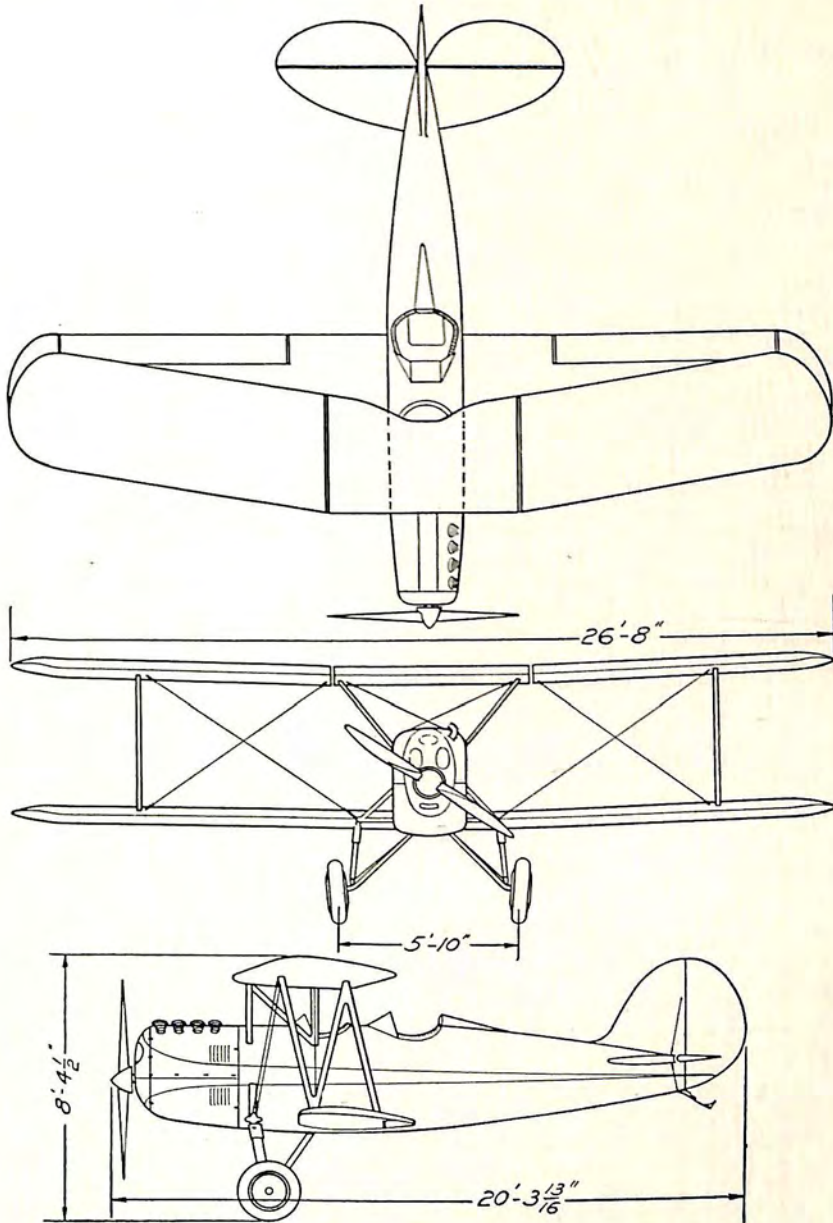

GREAT LAKES AIRCRAFT CORPORATION
Cleveland, Ohio
MODEL 2T-1A — 2 PLACE
ENGINE: AMERICAN CIRRUS

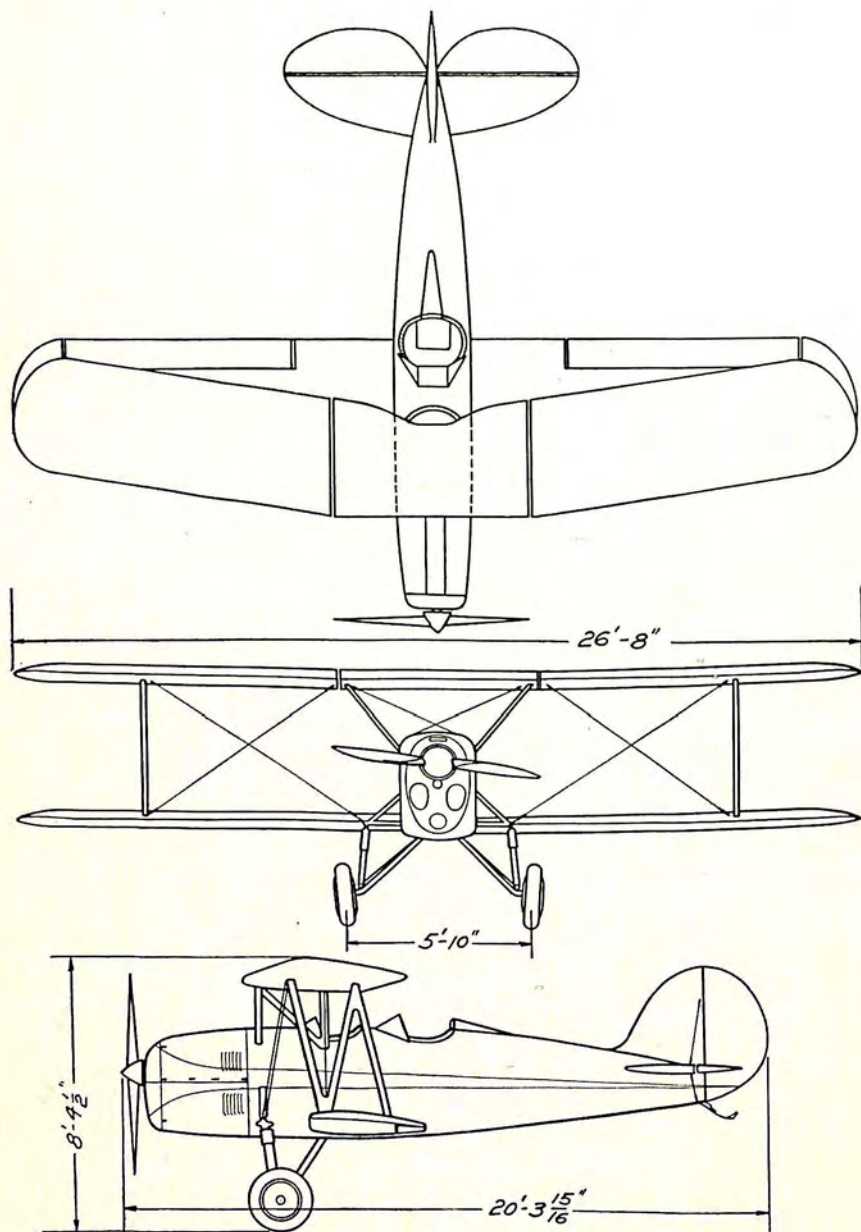

GREAT LAKES AIRCRAFT CORPORATION
Cleveland, Ohio

MODEL 2T-1E — 2 PLACE
ENGINE: HI-DRIVE AMERICAN CIRRUS

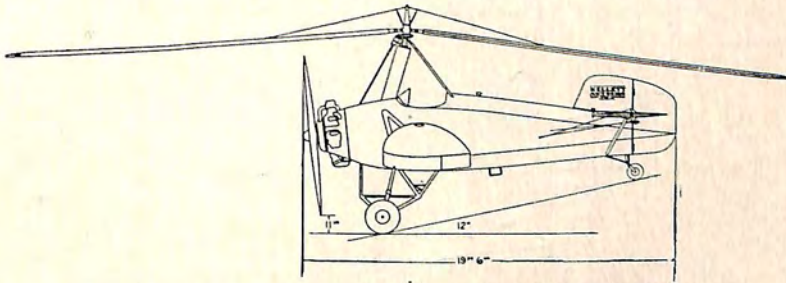
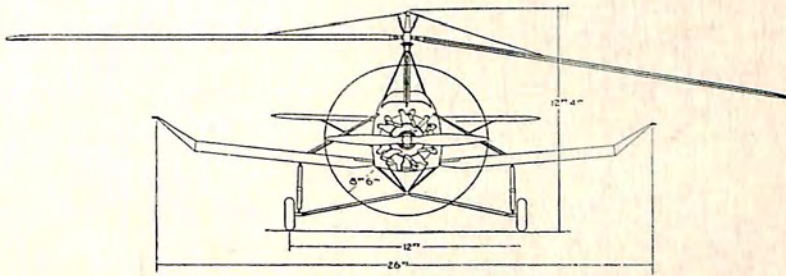
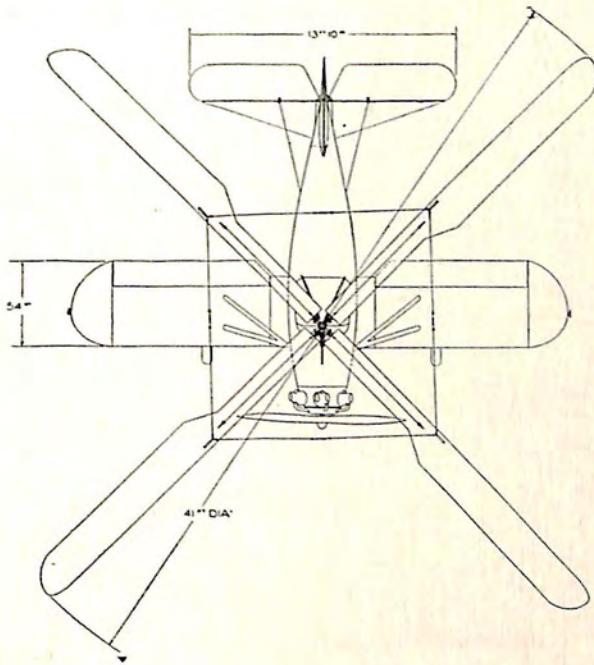

KELLETT AUTOGIRO CORPORATION
Philadelphia, Pa.
MODEL K-3 — 2 PLACE
ENGINE: KINNER C-5

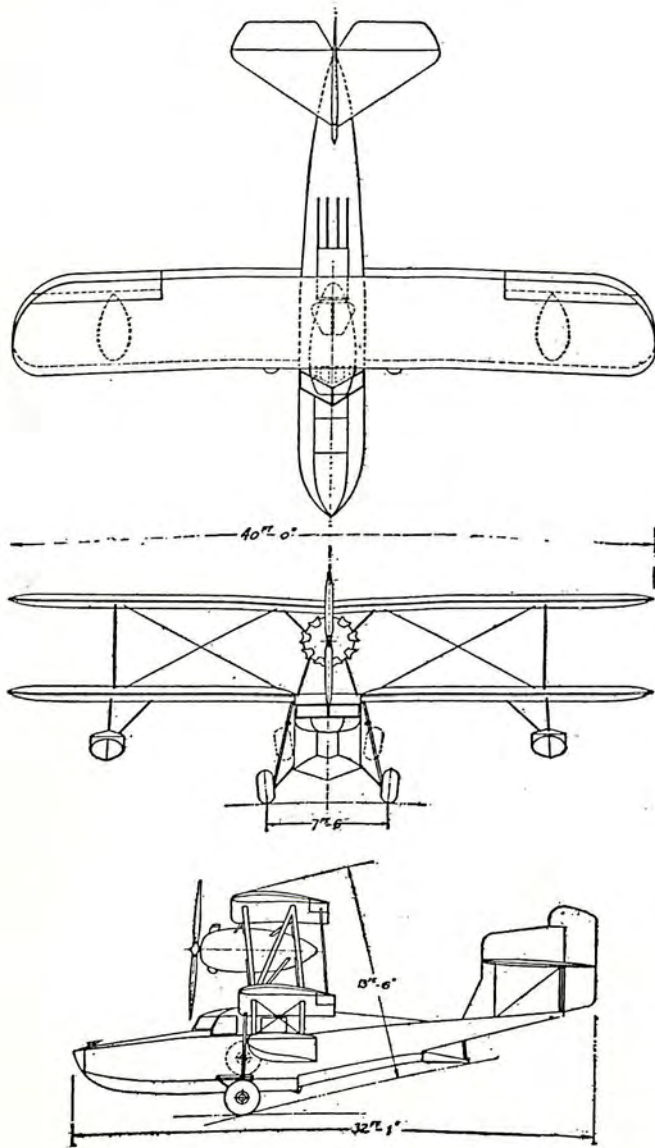

KEYSTONE AIRCRAFT CORPORATION
Bristol, Pa.

COMMUTER — 4 PLACE
ENGINE: WRIGHT WHIRLWIND 300

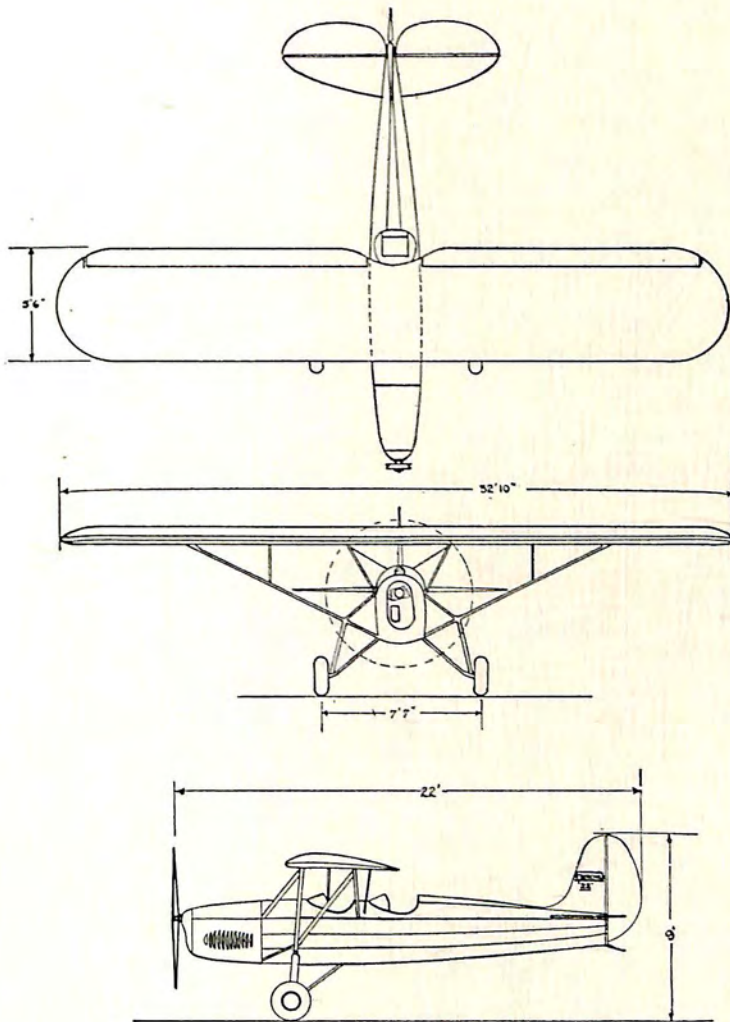

KREIDER-REISNER AIRCRAFT COMPANY, INC.
Hagerstown, Md.

FAIRCHILD 22 — 2 PLACE
ENGINE: HI-DRIVE AMERICAN CIRRUS
MENASCO C-4

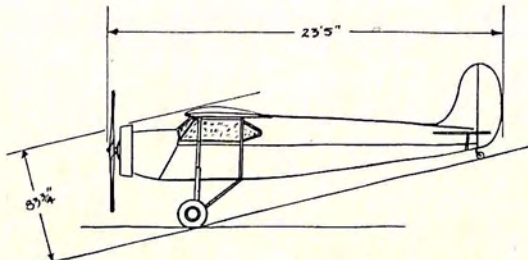
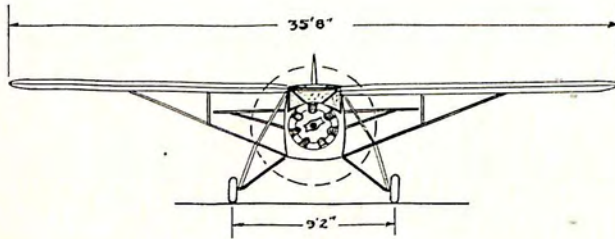
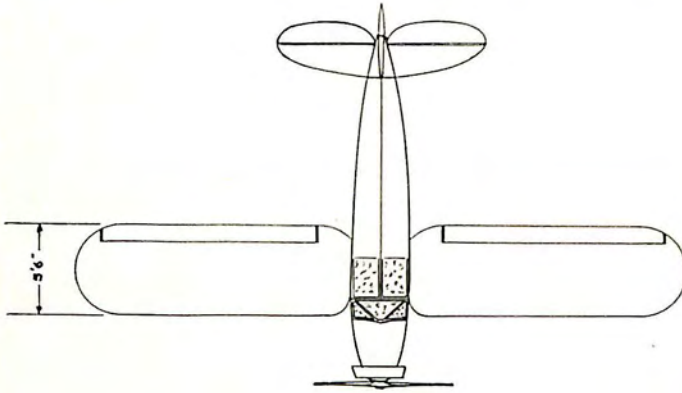

KREIDER-REISNER AIRCRAFT COMPANY, INC.
Hagerstown, Md.

FAIRCHILD 24 — 2 PLACE
ENGINE: HI-DRIVE AMERICAN CIRRUS
WARNER SCARAB

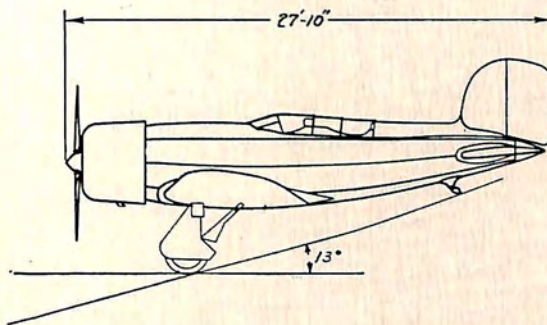
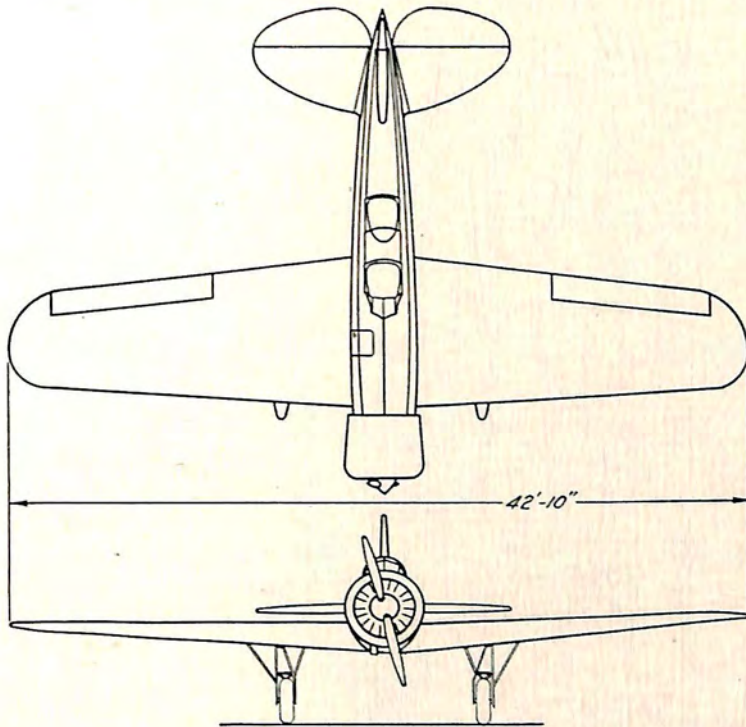

LOCKHEED AIRCRAFT CORPORATION
Burbank, Calif.
ALTAIR — 2 PLACE
ENGINE: PRATT & WHITNEY WASP
WRIGHT CYCLONE

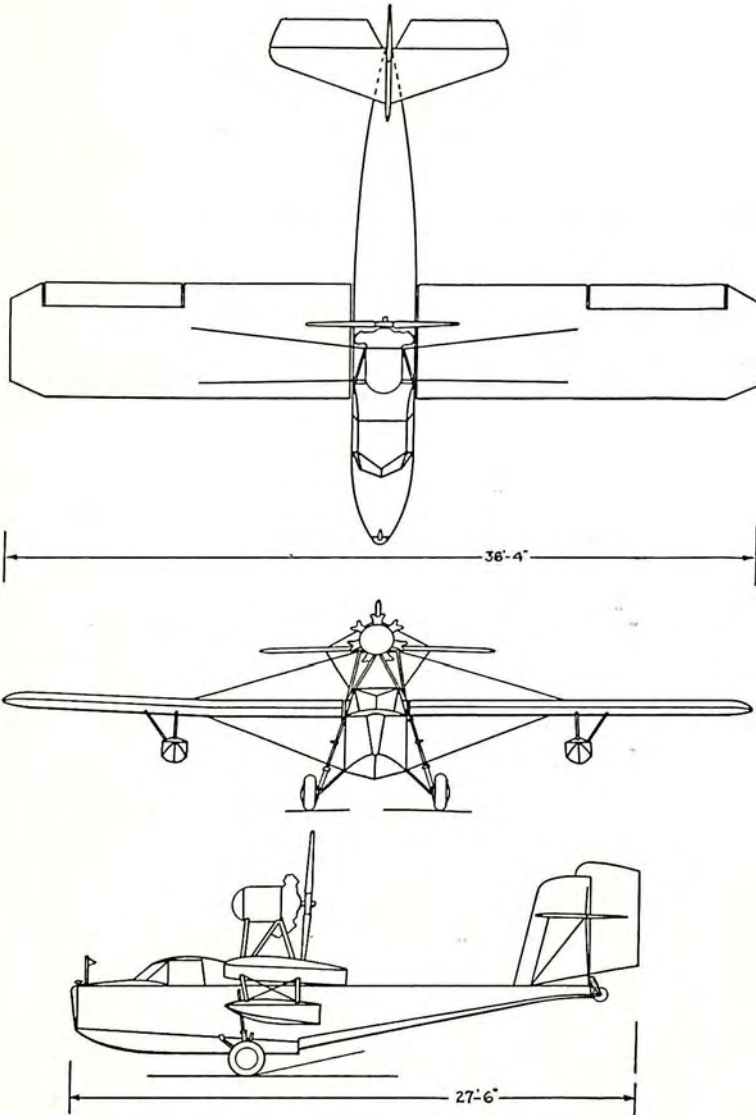

GROVER LOENING AIRCRAFT COMPANY, INC.
Garden City, L. I., N. Y.
DUCKLING — 2 PLACE
ENGINE: WARNER SCARAB

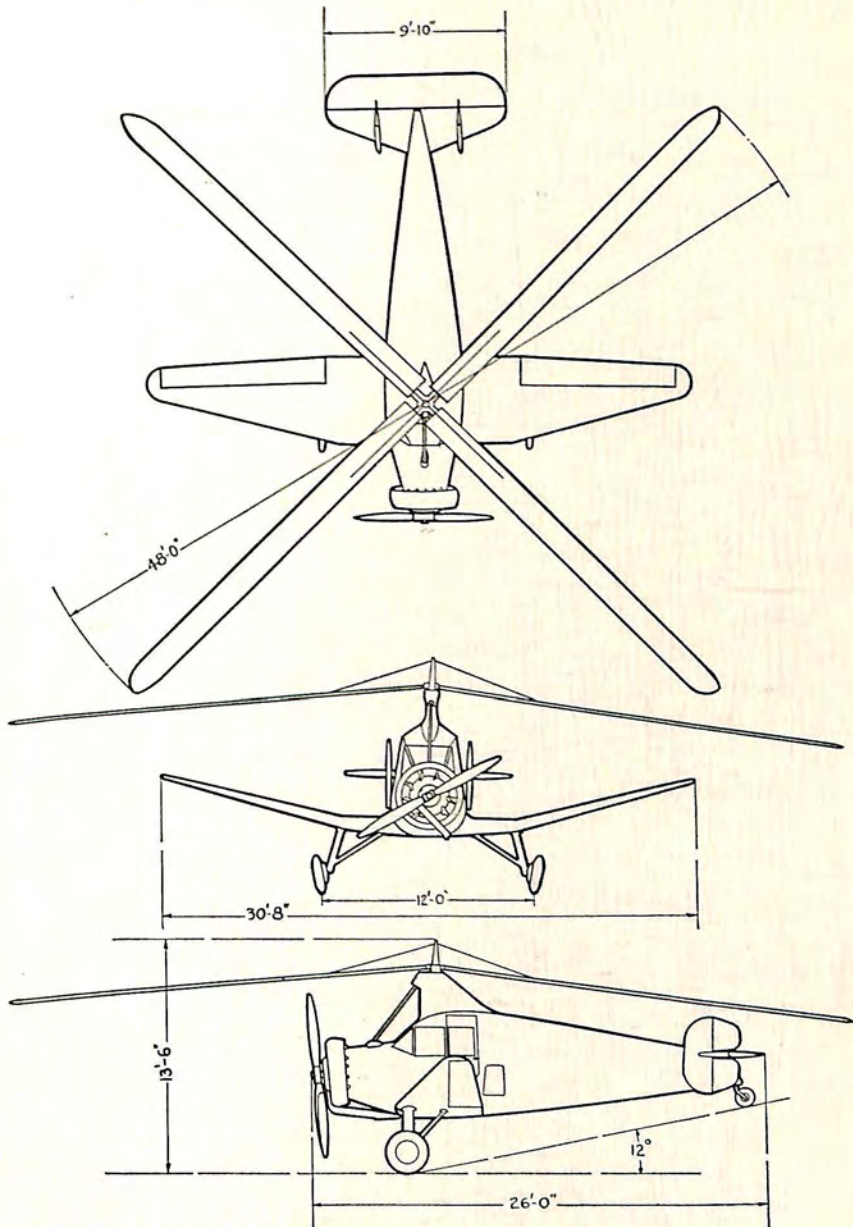

PITCAIRN AIRCRAFT, INCORPORATED
Willow Grove, Pa.

MODEL PA-19 — 4-5 PLACE

ENGINE: PRATT & WHITNEY WASP
WRIGHT WHIRLWIND 420

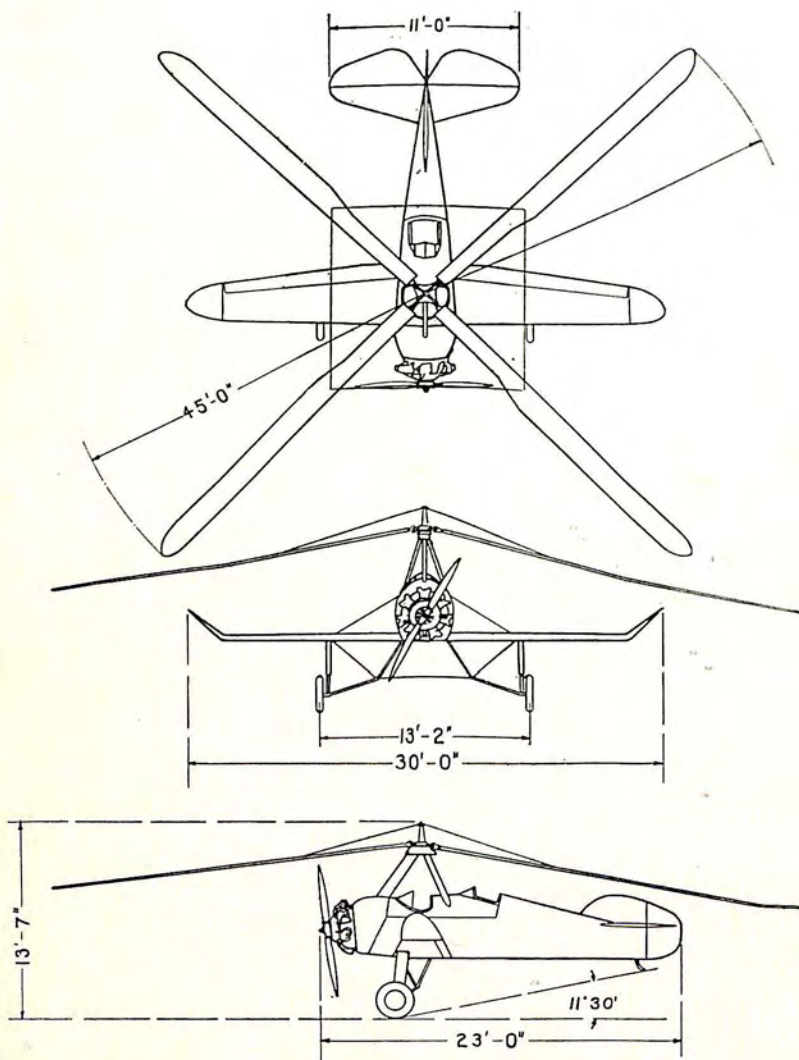

PITCAIRN AIRCRAFT, INCORPORATED
 Willow Grove, Pa.
 MODEL PCA-2; PCA-3 — 3 PLACE
 ENGINE: PRATT & WHITNEY WASP, JR.
 WRIGHT WHIRLWIND 300

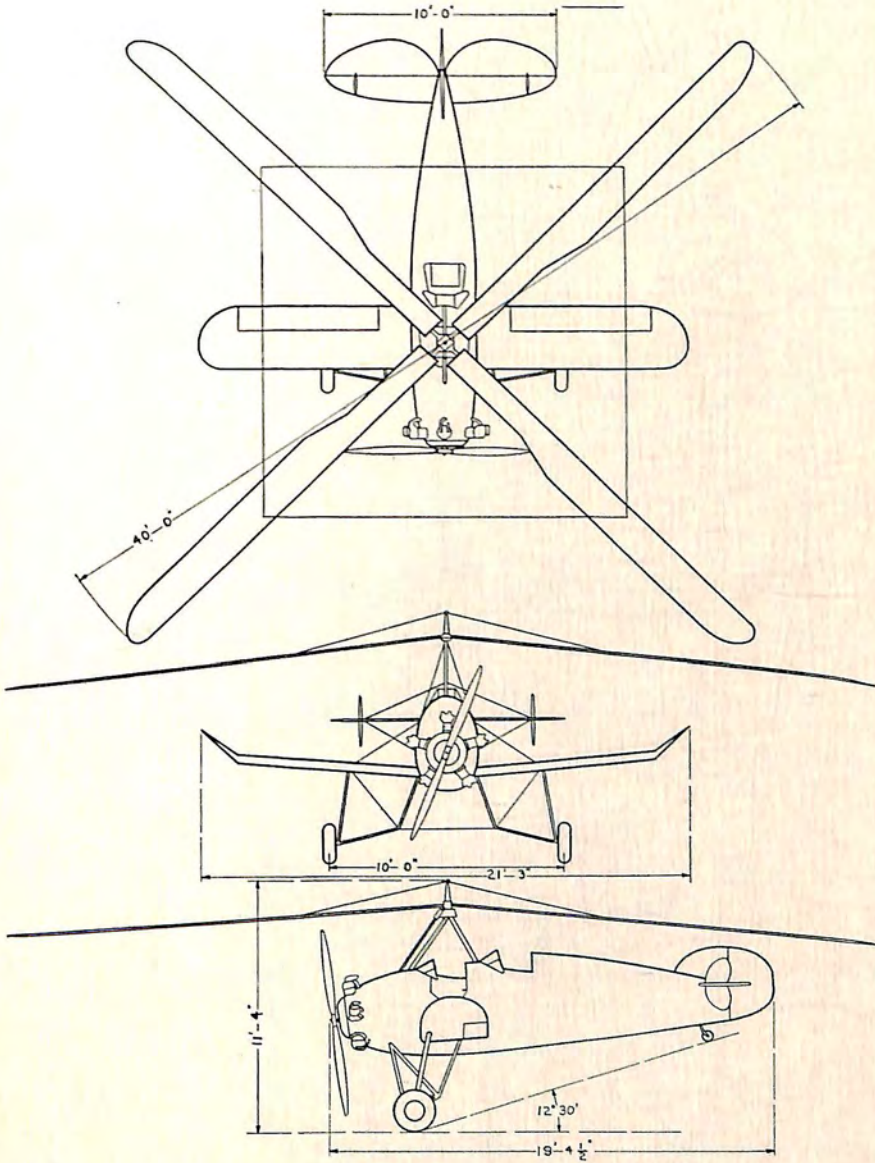

PITCAIRN AIRCRAFT, INCORPORATED
Willow Grove, Pa.

MODEL PA-18 — 2 PLACE

ENGINE: KINNER R-5

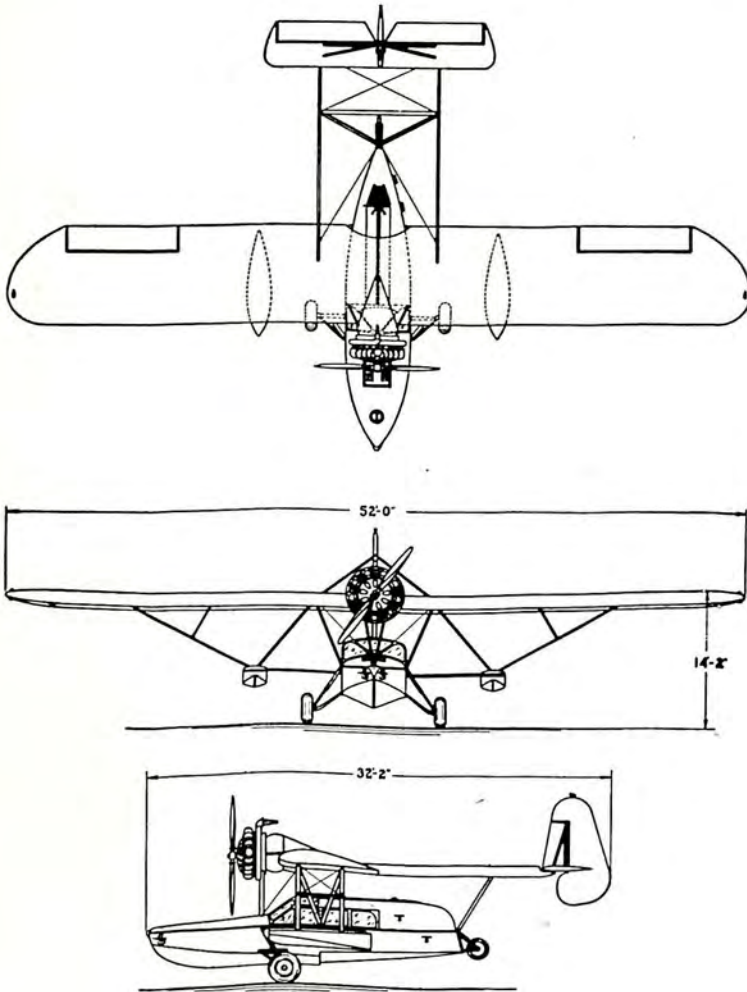

SIKORSKY AVIATION CORPORATION
Bridgeport, Conn.
AMPHIBION S-39 — 5 PLACE
ENGINE: PRATT & WHITNEY WASP, JR.

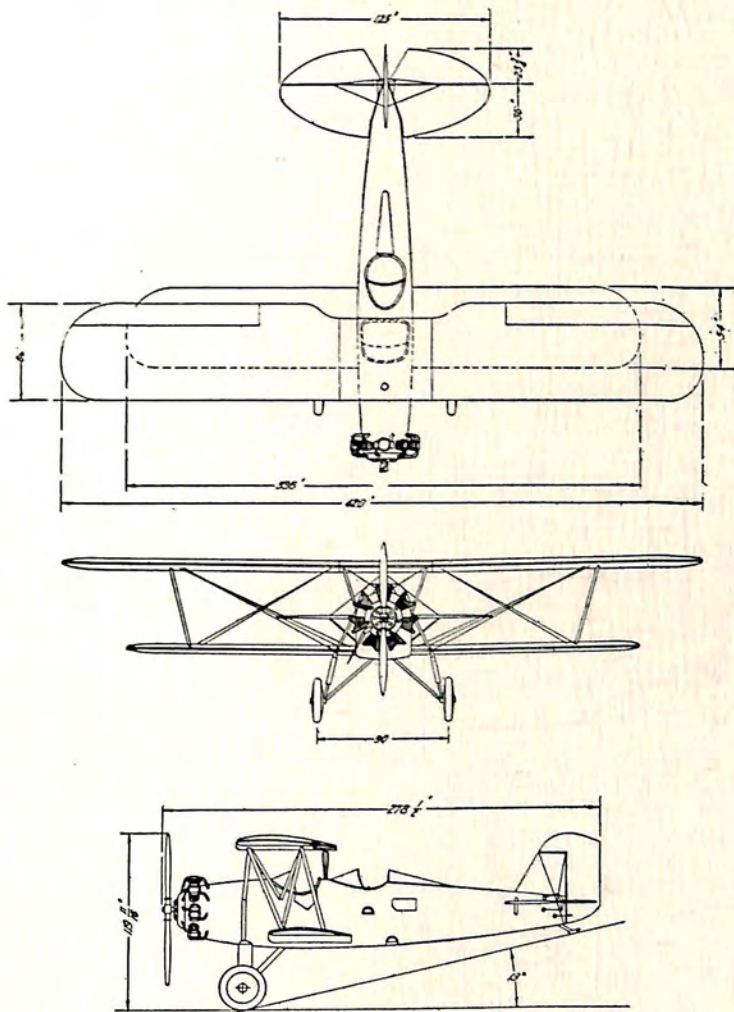

STEARMAN AIRCRAFT COMPANY
Wichita, Kan.
MODEL C 3R — 3 PLACE
ENGINE: WRIGHT WHIRLWIND 240

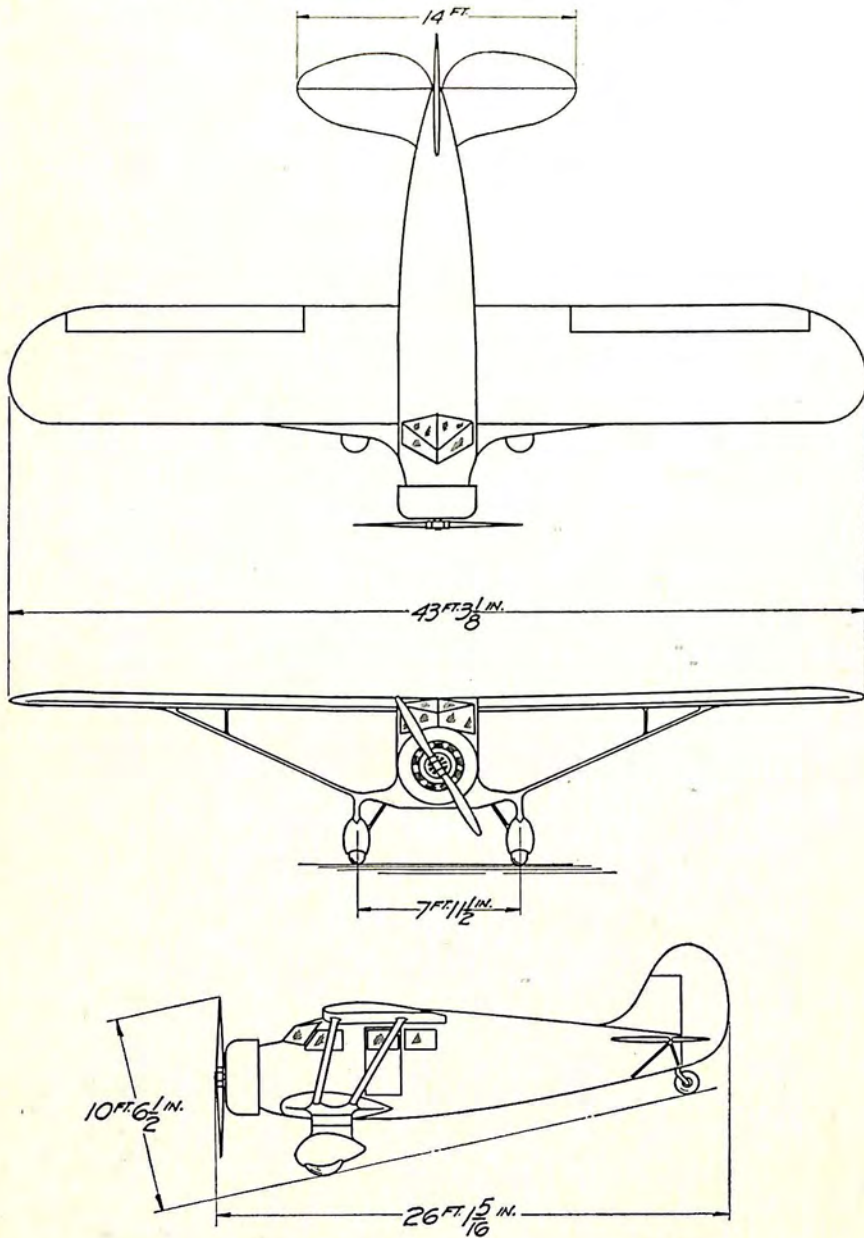

STINSON AIRCRAFT CORPORATION
Wayne, Mich.

MODEL R — 4 PLACE

ENGINE: LYCOMING

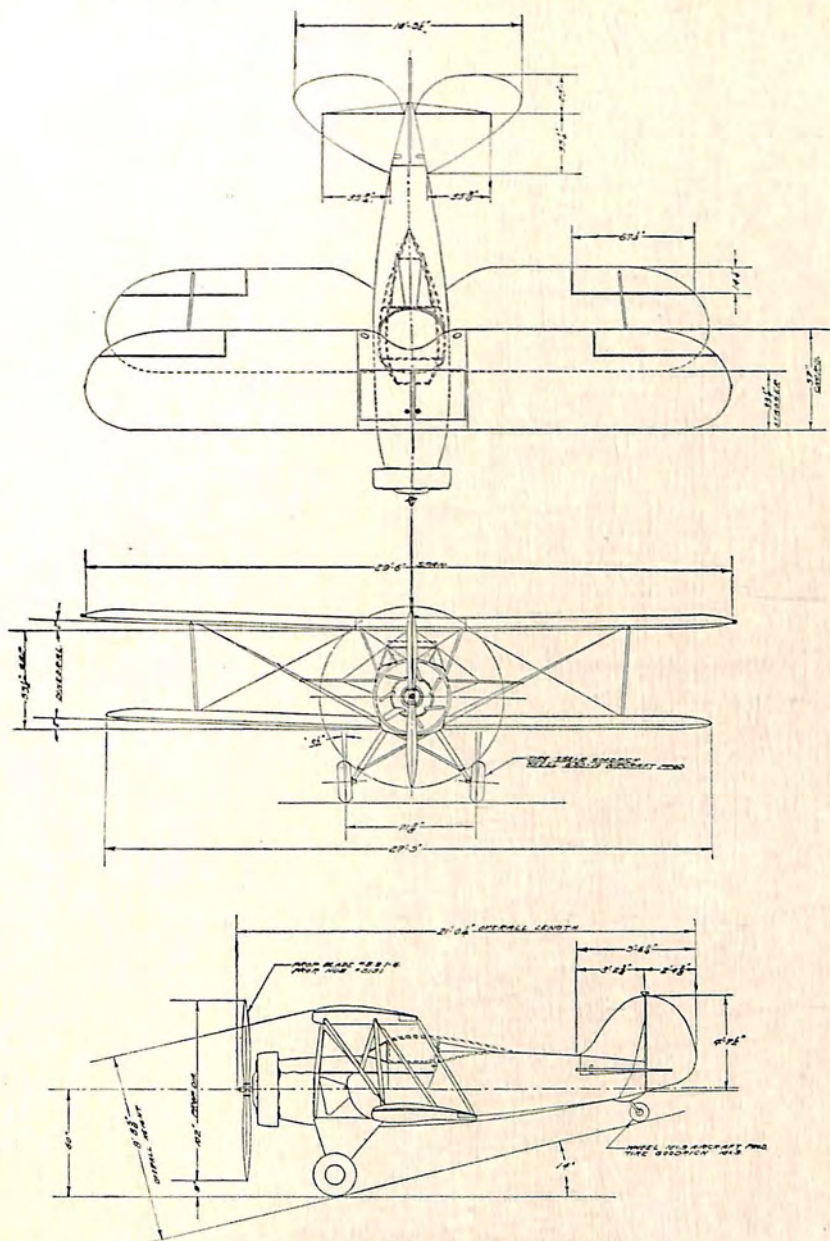

WACO AIRCRAFT COMPANY
 Troy, Ohio
 MODEL A — 2 PLACE
 ENGINE: CONTINENTAL
 JACOBS LA-1
 KINNER K-5, B-5, R-5
 WARNER SCARAB

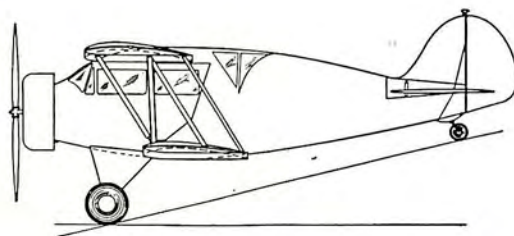
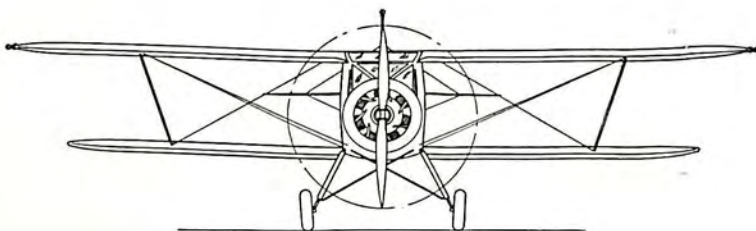
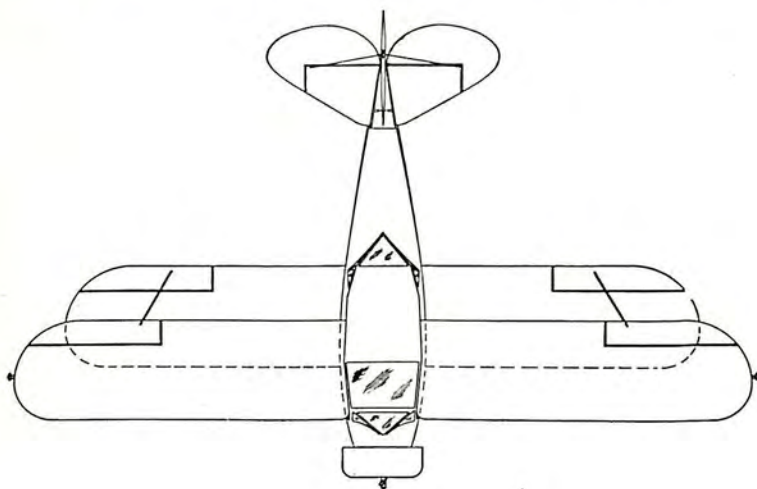

WACO AIRCRAFT COMPANY

Troy, Ohio

MODEL C — 4 PLACE

ENGINE: CONTINENTAL R-690

KINNER C-5

WRIGHT WHIRLWIND 165

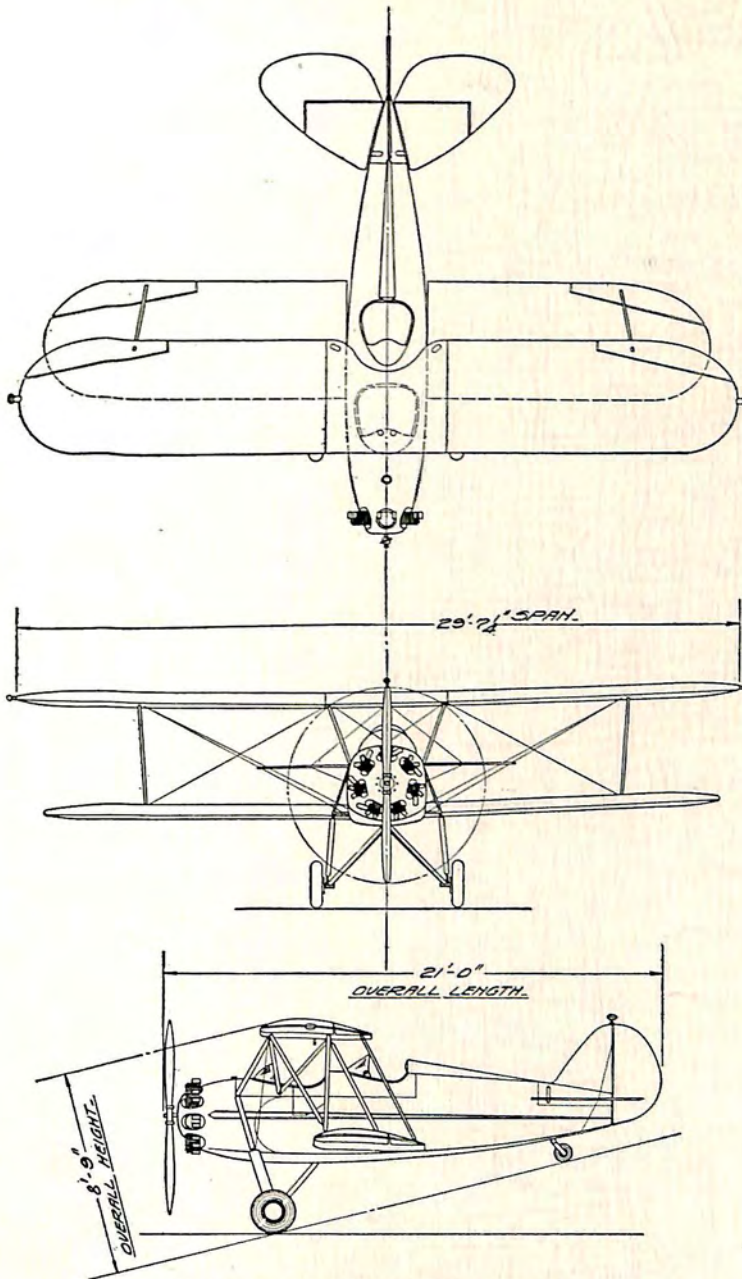

WACO AIRCRAFT COMPANY

Troy, Ohio

MODEL F — 3 PLACE

ENGINE: KINNER B-5

WARNER SCARAB

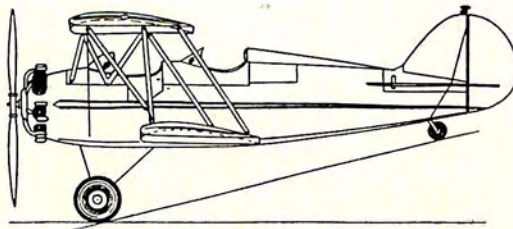
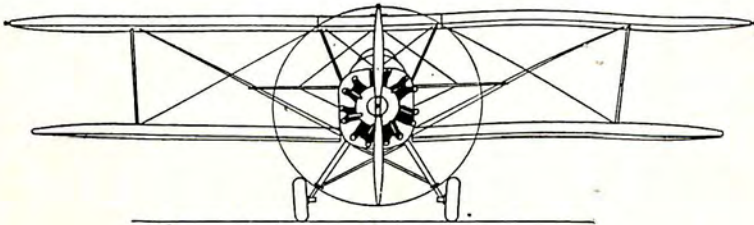
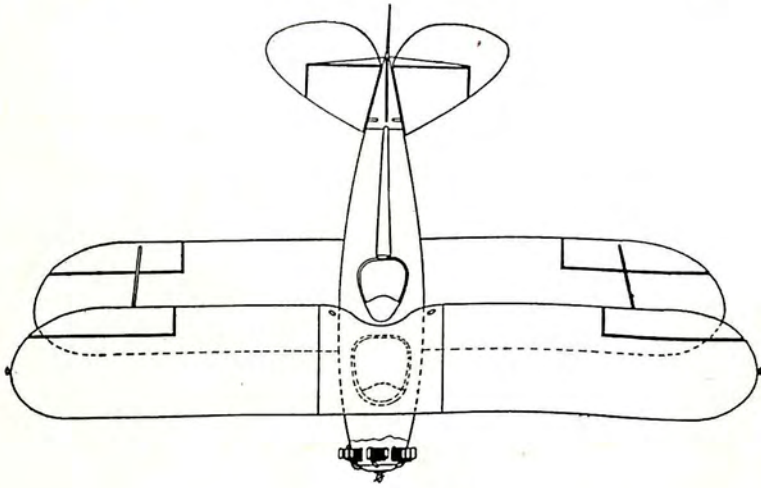

WACO AIRCRAFT COMPANY
Troy, Ohio
MODEL F2 — 3 PLACE
ENGINE: CONTINENTAL R-690
JACOBS LA-1

PRIVATE OPERATION AND AERIAL SERVICE

Name of Manufacturer	Model	Places	A.T.C. No.	Make of Engine	Total Rated H.P.	Wing Area Sq. Ft.	Gross Weight Lbs.	Pay Load Lbs.	High Speed M.P.H.	Cruising Speed M.P.H.	Stalling Speed M.P.H.	Service Ceiling Ft.	Cruising Radius Mi.
Aeronautical Corp.	Aeronca C-3	2	396	Aeronca E-113A	36	142.2	875	360	80	65	44	14,000	220
Amphibions	P-3B	3	Pending	Continental	210	224	3,200	900	115	93	58	395
Bellanca Aircraft	Pacemaker	6	129	Packard Diesel	225	273	4,240	900	132	111	17,000	1,000
Bellanca Aircraft	Pacemaker	6	328	Pratt & Whitney Wasp, Jr.	300	273	4,300	933	150	125	17,000	850
Bellanca Aircraft	Pacemaker	6	129	Wright Whirlwind 300	300	273	4,300	993	150	125	17,000	850
Bellanca Aircraft	Skyrocket	6	319	Pratt & Whitney Wasp	420	273	4,000	1,025	155	130	20,000	750
Curtiss-Wright Airplane	16-E	3	463	Wright Whirlwind 165	165	206	2,150	395	135	115	48	16,500	350
Curtiss-Wright Airplane	Speedwing	2-3	442	Wright Whirlwind 240	240	248	2,870	544	155	132	56	16,100	550
Curtiss-Wright Airplane	Speedwing	2-3	485	Wright Whirlwind 300	300	248	3,007	488	170	144	58	18,700	550
Curtiss-Wright Airplane	Speedwing	2-3	Pending	Wright Whirlwind 420	420	248	3,007	290	185	157	58	22,500	500
Great Lakes Aircraft	2T-1A	2	228	American Cirrus	100	187.6	1,580	564	110	90	48	13,100	370
Great Lakes Aircraft	2T-1E	2	354	Hi-Drive Amer. Cirrus	100	187.6	1,580	564	110	90	48	13,100	370
Kellett Autogiro	K-3	2	471	Kinner C-5	210	1,295	2,334	235	110	90	None
Keystone Aircraft	Commuter	4	219	Wright Whirlwind 300	300	437	4,150	640	112	87	50	12,000	400
Kreider-Reisner Aircraft	C-7A	2	438	Hi-Drive Amer. Cirrus	95	170	1,500	225	114	94	42	13,000	300
Kreider-Reisner Aircraft	C-7B	2	483	Menasco C-4	125	170	1,600	201	125	106	44	20,000	430
Kreider-Reisner Aircraft	C-8	2	475	Hi-Drive Amer. Cirrus	95	185	1,600	217	114	94	44	12,000	350
Kreider-Reisner Aircraft	C-8A	2	Pending	Warner Scarab	110	185	1,750	225	120	105	48	16,000	350
Lockheed Aircraft	Altair	2	Pratt & Whitney Wasp	450	294.1	5,200	Variable	220	180	68	20,000	1,375
Lockheed Aircraft	Altair	2	Wright Cyclone	575	294.1	5,200	Variable	226	190	70	22,000	1,100
Grover Loening Aircraft	Duckling	2	Warner Scarab	110	196	2,000	250	102	83	50
Pitcairn Aircraft	PA-19	4-5	Pending	Pratt & Whitney Wasp	420	4,000	680	None
Pitcairn Aircraft	PA-19	4-5	Pending	Wright Whirlwind 420	420	4,000	680	None
Pitcairn Aircraft	PCA-2	3	410	Wright Whirlwind	300	1,590	3,000	376	118	95	None
Pitcairn Aircraft	PCA-3	3	446	Pratt & Whitney Wasp, Jr.	300	1,590	3,036	415	126	95	None
Pitcairn Aircraft	PA-18	2	478	Kinner R-5	160	1,260	1,900	180	100	85	None
Sikorsky Aviation	Amphib. S-39	5	375	Pratt & Whitney Wasp, Jr.	300	350	4,000	717	123	100	50	14,000	400
Stearman Aircraft	C3R	3	251	Wright Whirlwind 240	240	288	2,754	361	136	110	53	16,600	458
Stinson Aircraft	R	4	457	Lycoming	215	235	3,325	560	130	110	52	12,500	460
Waco Aircraft	UBA	2	479	Continental	170	241.5	2,250	459	132	116	42	16,500	357
Waco Aircraft	PBA	2	464	Jacobs LA-1	170	241.5	2,250	441	119	101	42	14,500	404
Waco Aircraft	KCA	2	460	Kinner K-5	100	241.5	1,985	341	101	86	40	10,500	500
Waco Aircraft	IBA	2	465	Kinner B-5	125	241.5	1,985	398	114	98	40	15,000	500
Waco Aircraft	TBA	2	474	Kinner R-5	160	241.5	2,053	455	119	101	40	15,000	400
Waco Aircraft	RBA	2	466	Warner Scarab	110	241.5	1,985	350	105	91	40	12,800	416
Waco Aircraft	UEC	4	467	Continental R-690	210	240	2,700	598	130	116	49	14,400	447
Waco Aircraft	OEC	4	468	Kinner C-5	210	240	2,700	593	133	117	49	15,000	450
Waco Aircraft	BEC	4	472	Wright Whirlwind 165	165	240	2,700	598	121	106	49	13,000	530
Waco Aircraft	INF	3	345	Kinner B-5	125	242	1,938	355	112	96	40	15,000	410
Waco Aircraft	RNF	3	311	Warner Scarab	110	242	1,938	372	103	90	40	12,800	411
Waco Aircraft	UBF	3	473	Continental R-690	210	241.5	2,300	484	132	116	42	16,500	357
Waco Aircraft	PBF	3	491	Jacobs LA-1	170	241.5	2,300	516	119	101	42	14,500	404

PRIVATE OPERATION AND AERIAL SERVICE

MILITARY AIRPLANES

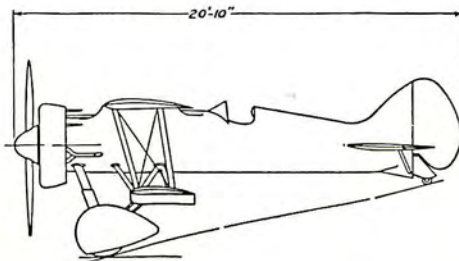
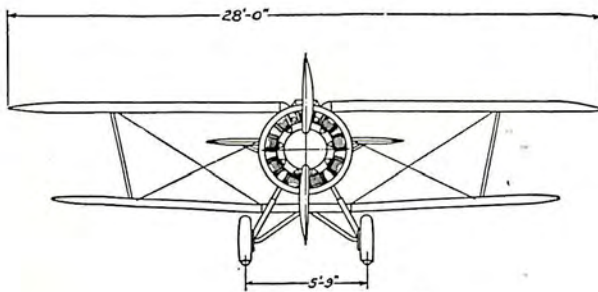
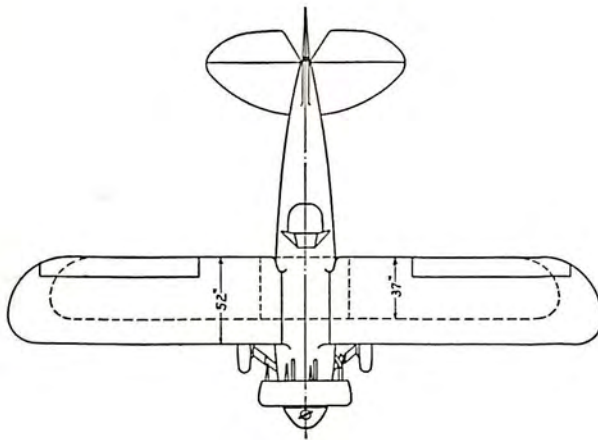

B/J AIRCRAFT CORPORATION
Baltimore, Md.
FIGHTER XFJ-2
ENGINE: PRATT & WHITNEY WASP

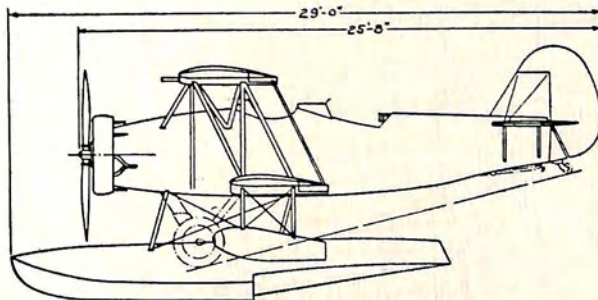
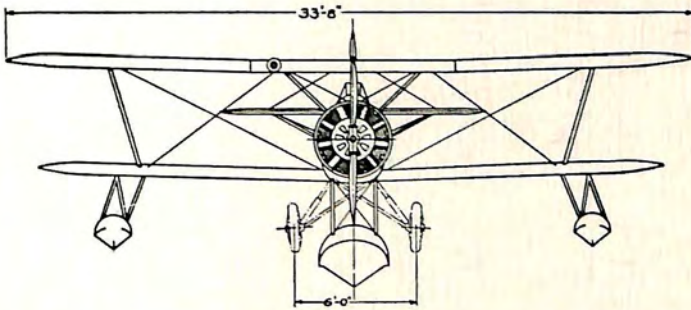
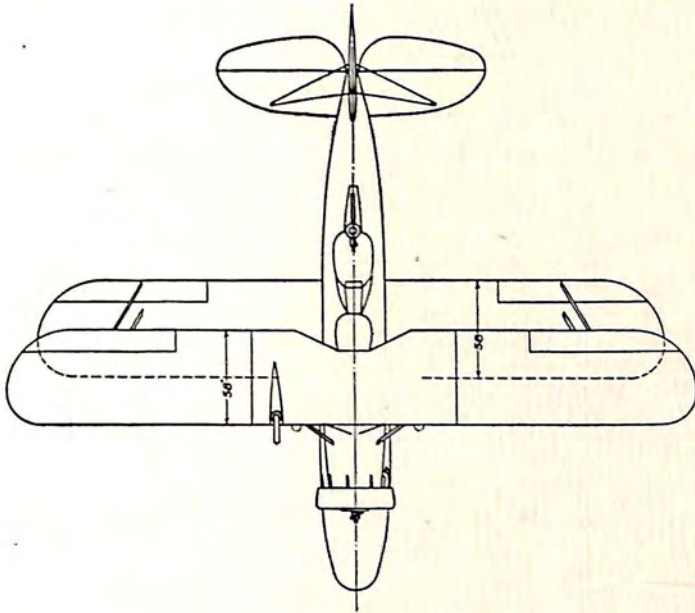

B/J AIRCRAFT CORPORATION
Baltimore, Md.
OBSERVATION OJ-2
ENGINE: PRATT & WHITNEY WASP, JR.

MILITARY AIRPLANES

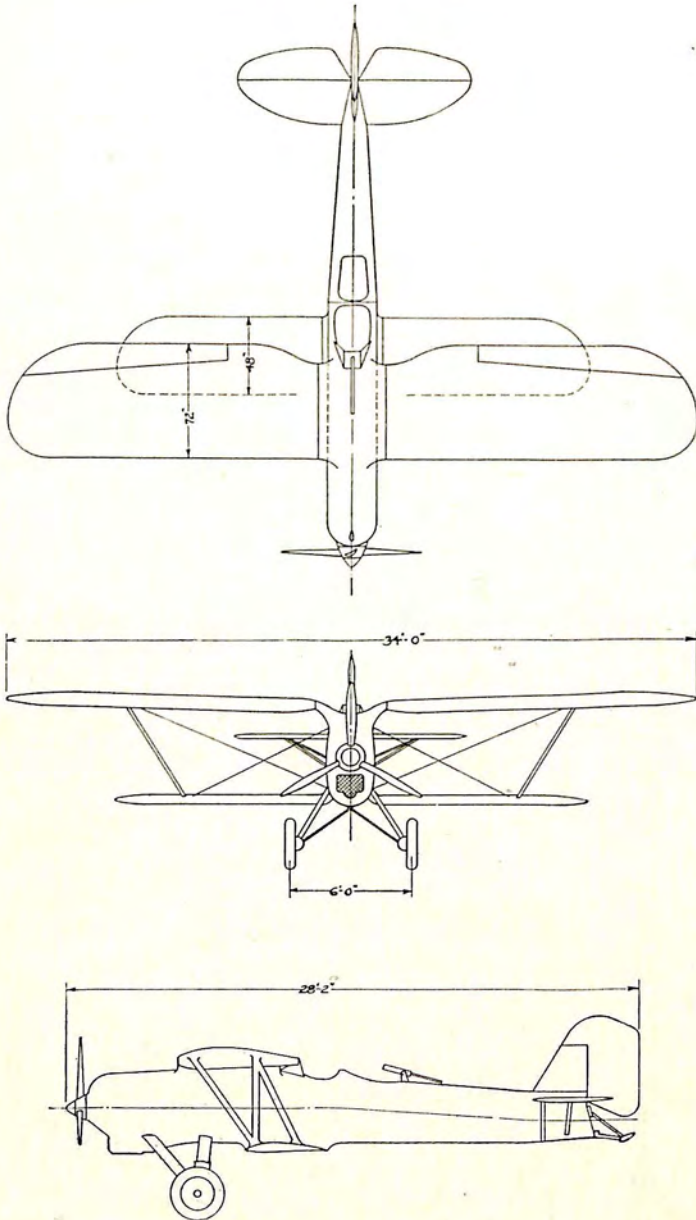

B/J AIRCRAFT CORPORATION
Baltimore, Md.
PURSUIT Y1P-16
ENGINE: CURTISS CONQUEROR

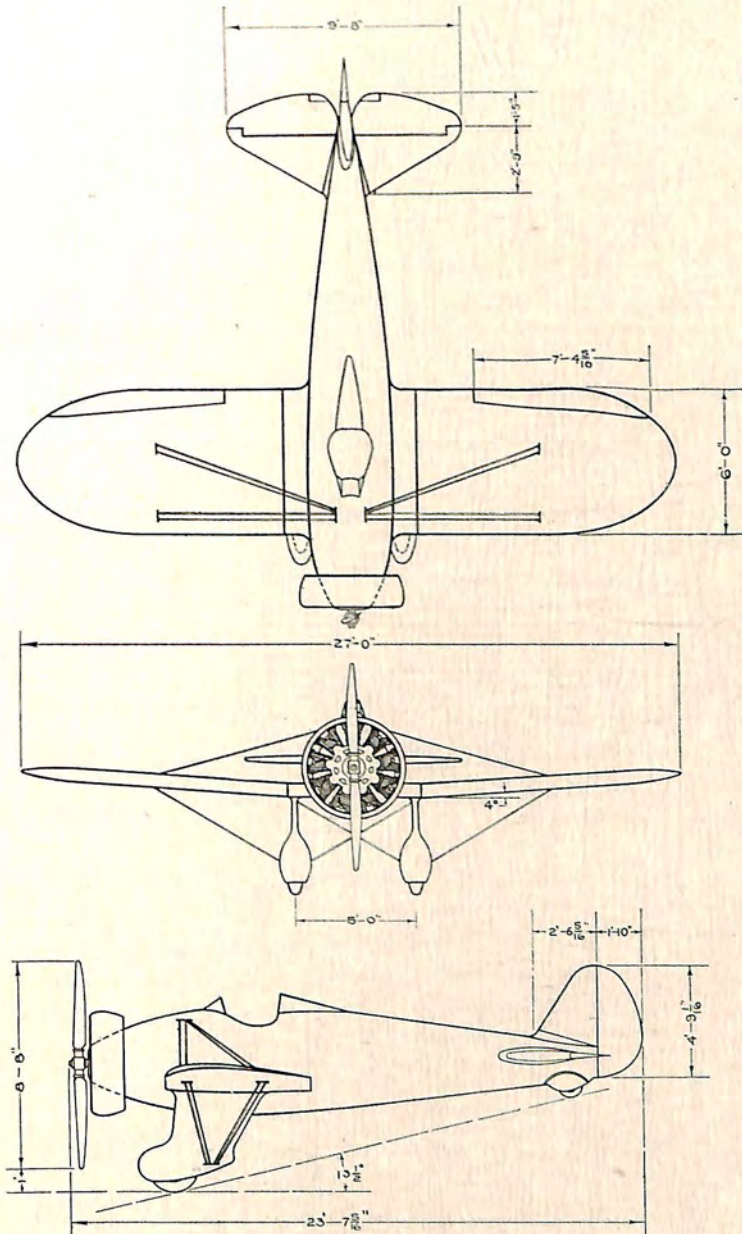

BOEING AIRPLANE COMPANY
 Seattle, Wash.
 PURSUIT XP-936
 ENGINE: PRATT & WHITNEY WASP

MILITARY AIRPLANES

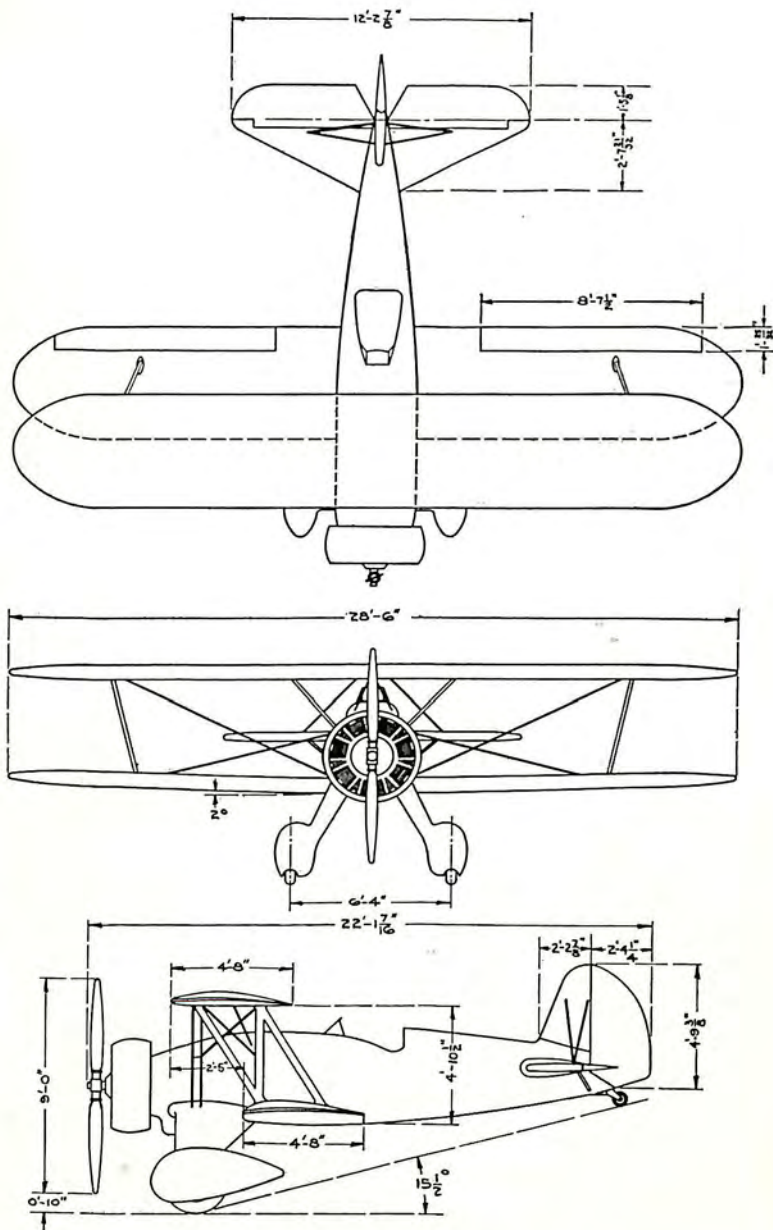

BOEING AIRPLANE COMPANY
 Seattle, Wash.
 FIGHTER XF6B-1
 ENGINE: PRATT & WHITNEY TWIN WASP, JR.

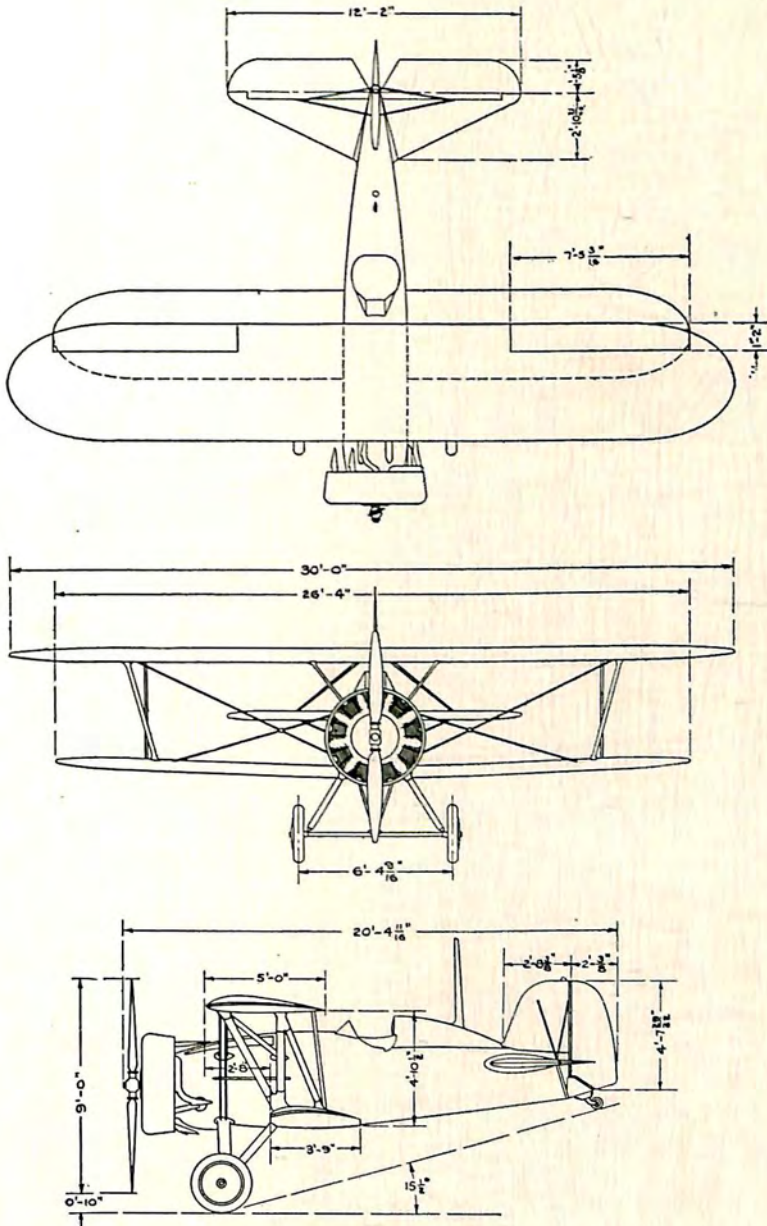

BOEING AIRPLANE COMPANY
 Seattle, Wash.
 FIGHTER F4B-4
 ENGINE: PRATT & WHITNEY WASP

MILITARY AIRPLANES

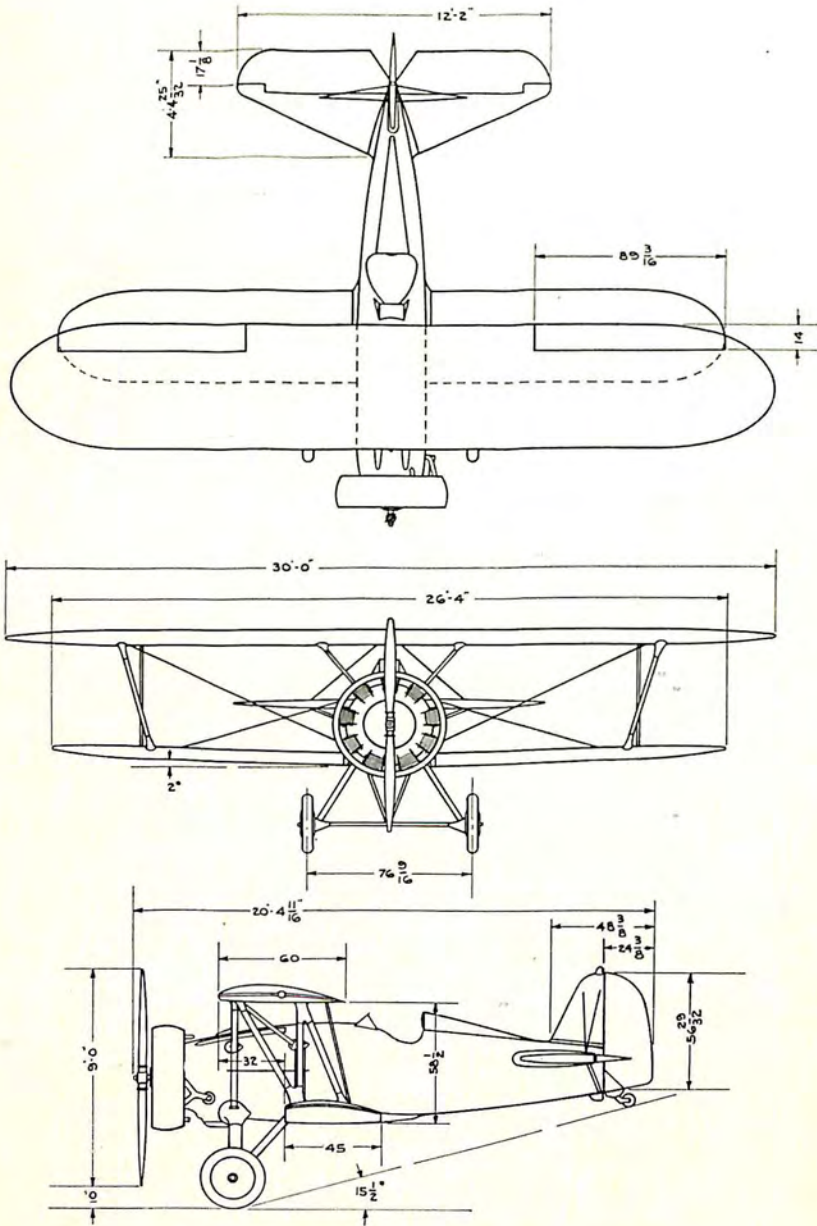

BOEING AIRPLANE COMPANY
Seattle, Wash.

MODEL P-12F — F4B-3

ENGINE: PRATT & WHITNEY WASP

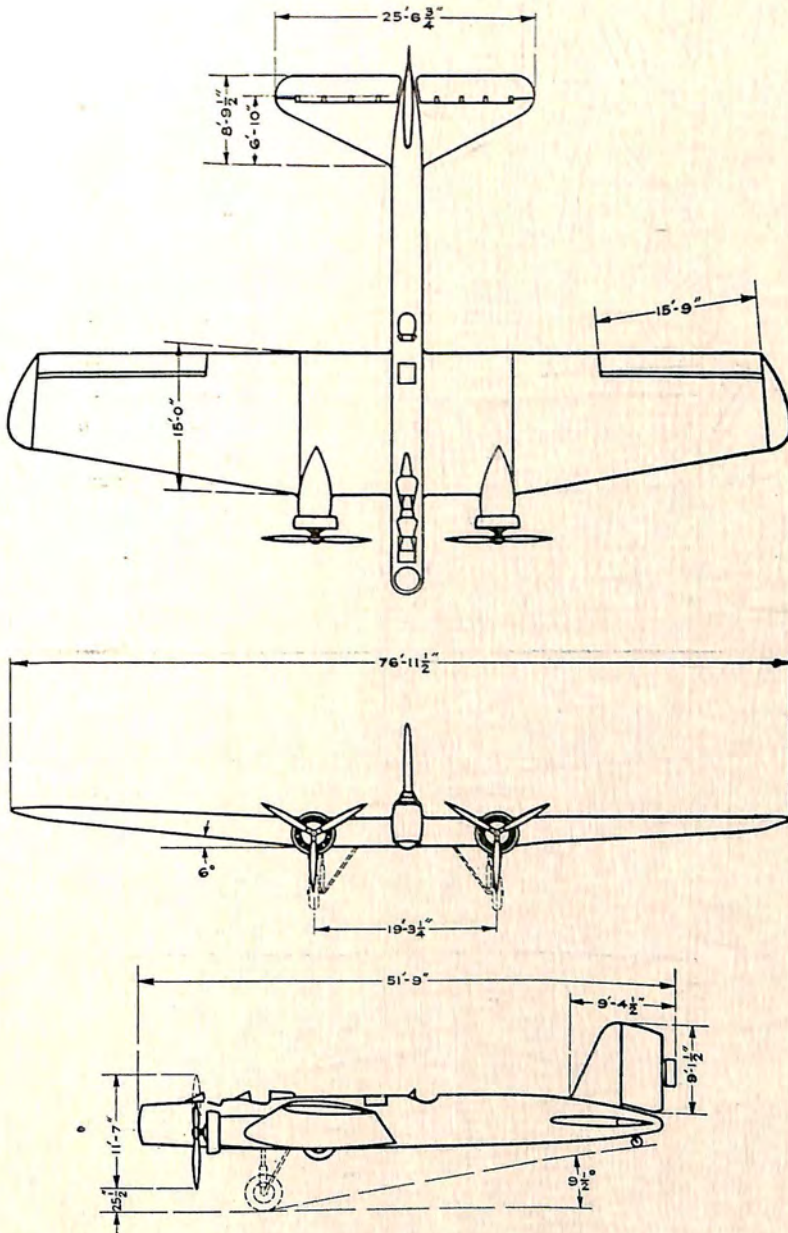

BOEING AIRPLANE COMPANY
 Seattle, Wash.
 BOMBER Y1B-9A
 ENGINE: TWO PRATT & WHITNEY HORNETS

MILITARY AIRPLANES

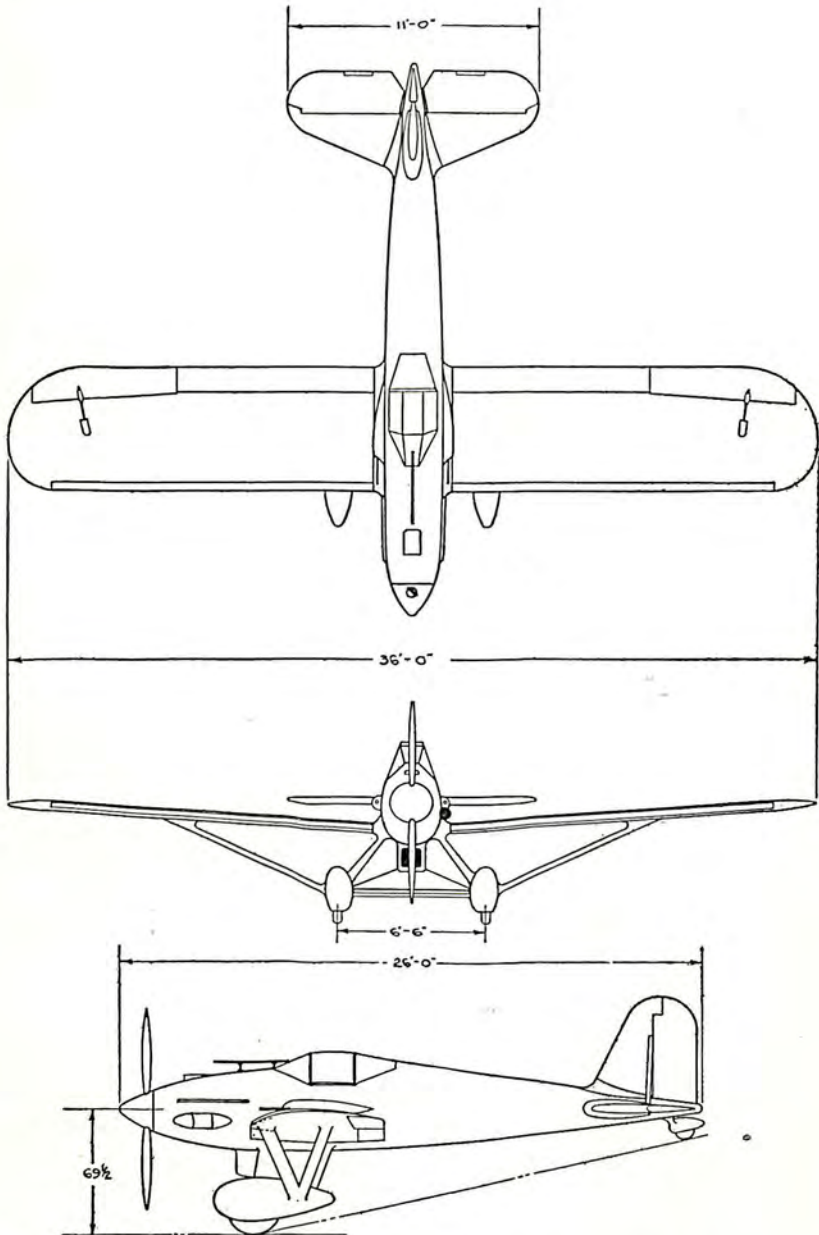

CURTISS AEROPLANE & MOTOR COMPANY
Buffalo, N. Y.

PURSUIT XP-934 — "SWIFT"

ENGINE: CURTISS CONQUEROR

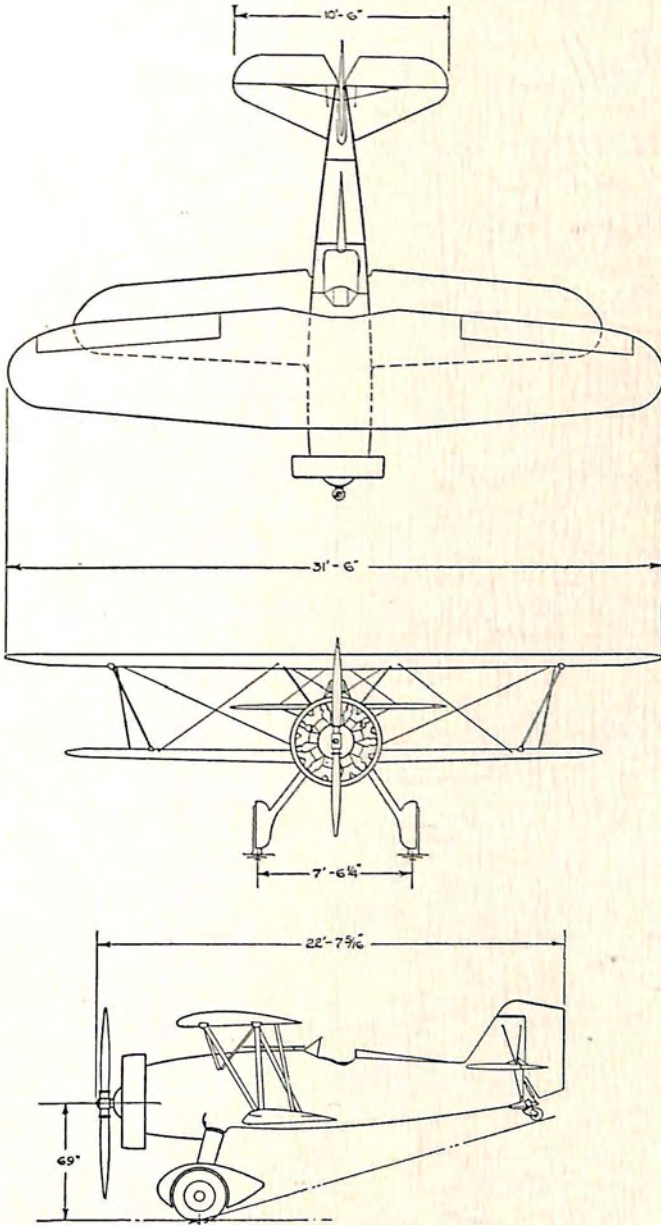

CURTISS AEROPLANE & MOTOR COMPANY
Buffalo, N. Y.
FIGHTER F11C-2
ENGINE: WRIGHT CYCLONE

MILITARY AIRPLANES

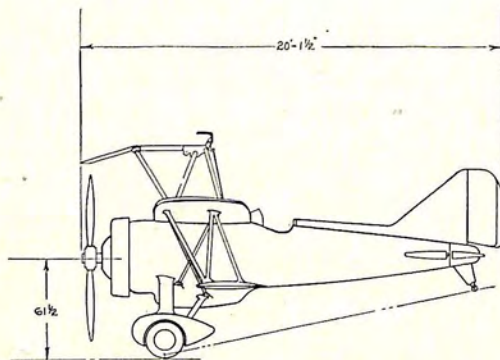
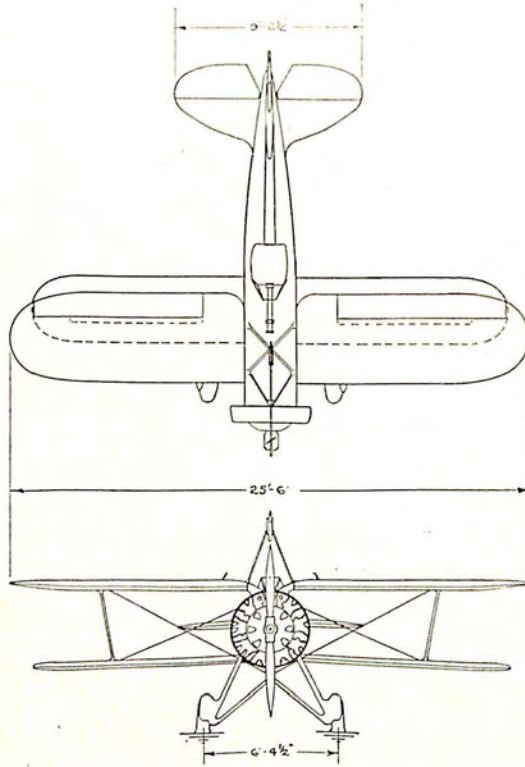

CURTISS AEROPLANE & MOTOR COMPANY
Buffalo, N. Y.

FIGHTER F9C-2

ENGINE: WRIGHT WHIRLWIND 420

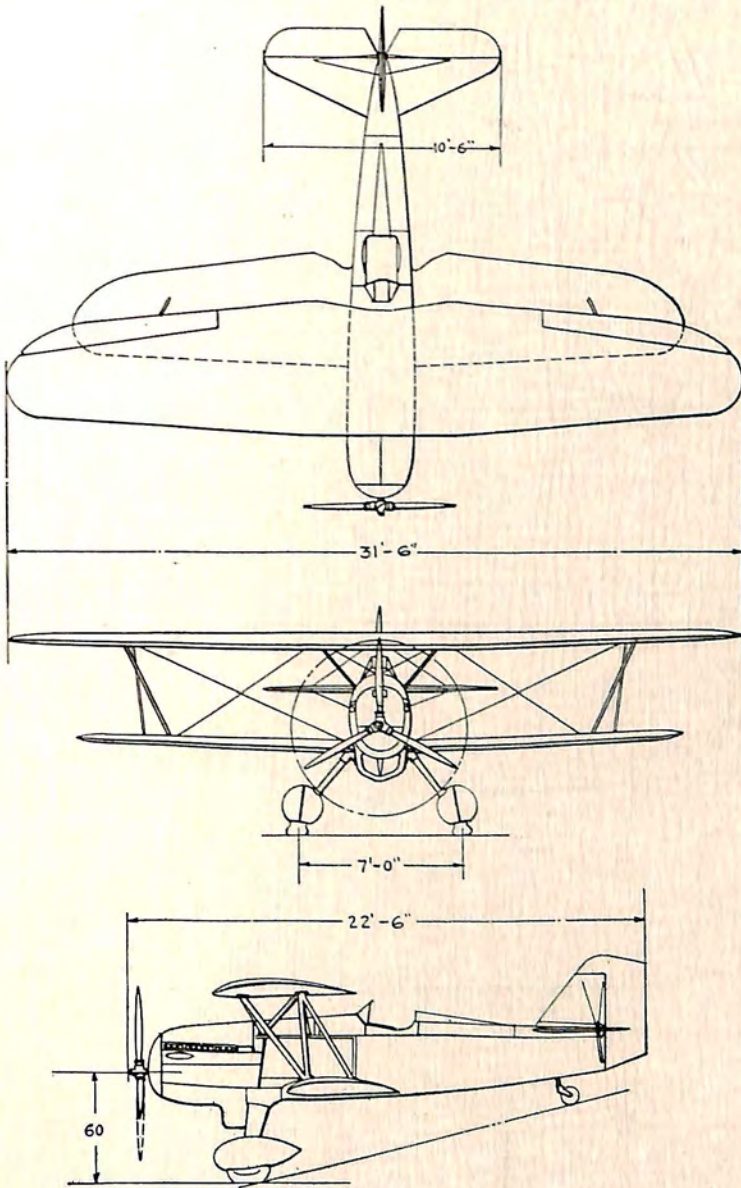

CURTISS AEROPLANE & MOTOR COMPANY, INC.
Buffalo, N. Y.
PURSUIT P 6-E
ENGINE: CURTISS CONQUEROR

MILITARY AIRPLANES

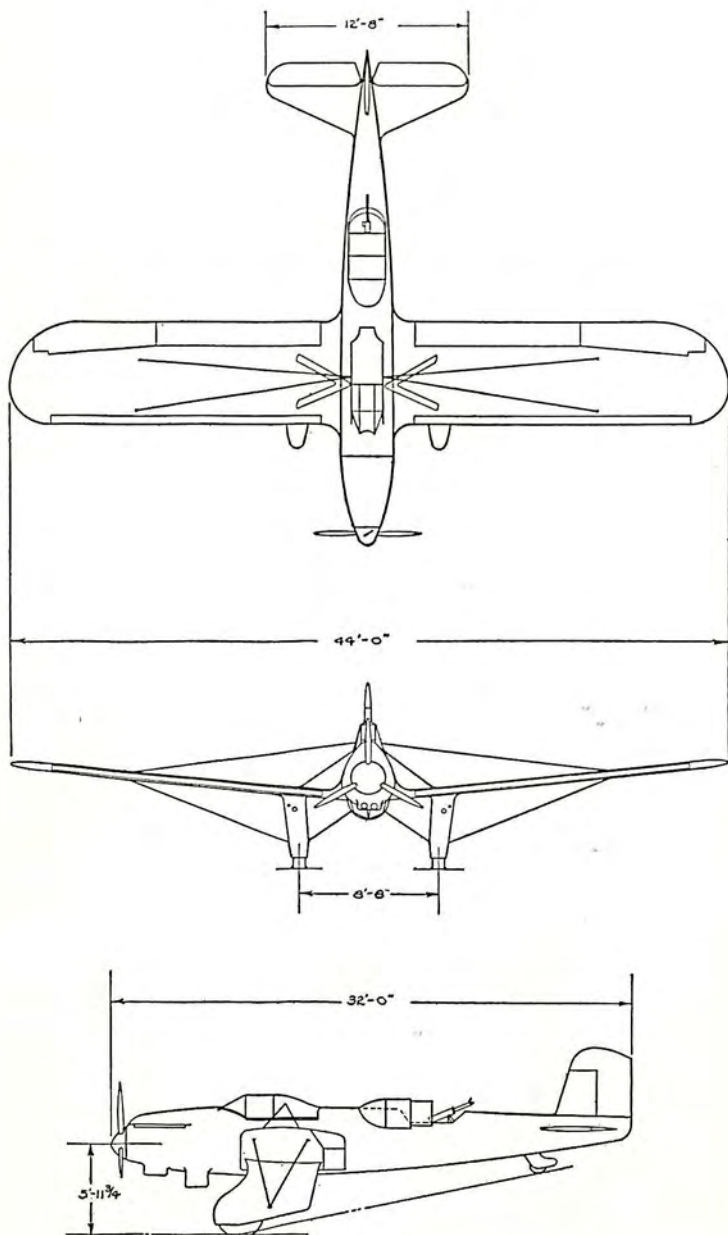

CURTISS AEROPLANE & MOTOR COMPANY
Buffalo, N. Y.
ATTACK YA-8 — "SHRIKE"
ENGINE: CURTISS CONQUEROR

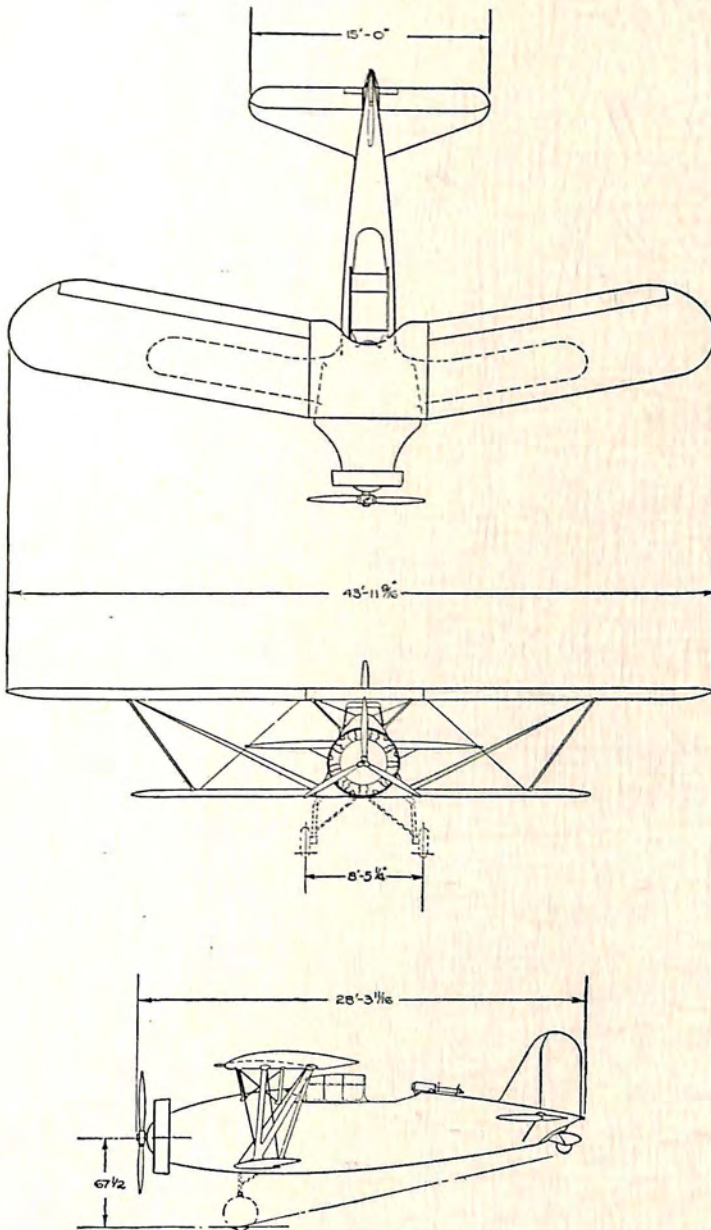

CURTISS AEROPLANE & MOTOR COMPANY
Buffalo, N. Y.

OBSERVATION YO-40 — "RAVEN"

ENGINE: WRIGHT CYCLONE

MILITARY AIRPLANES

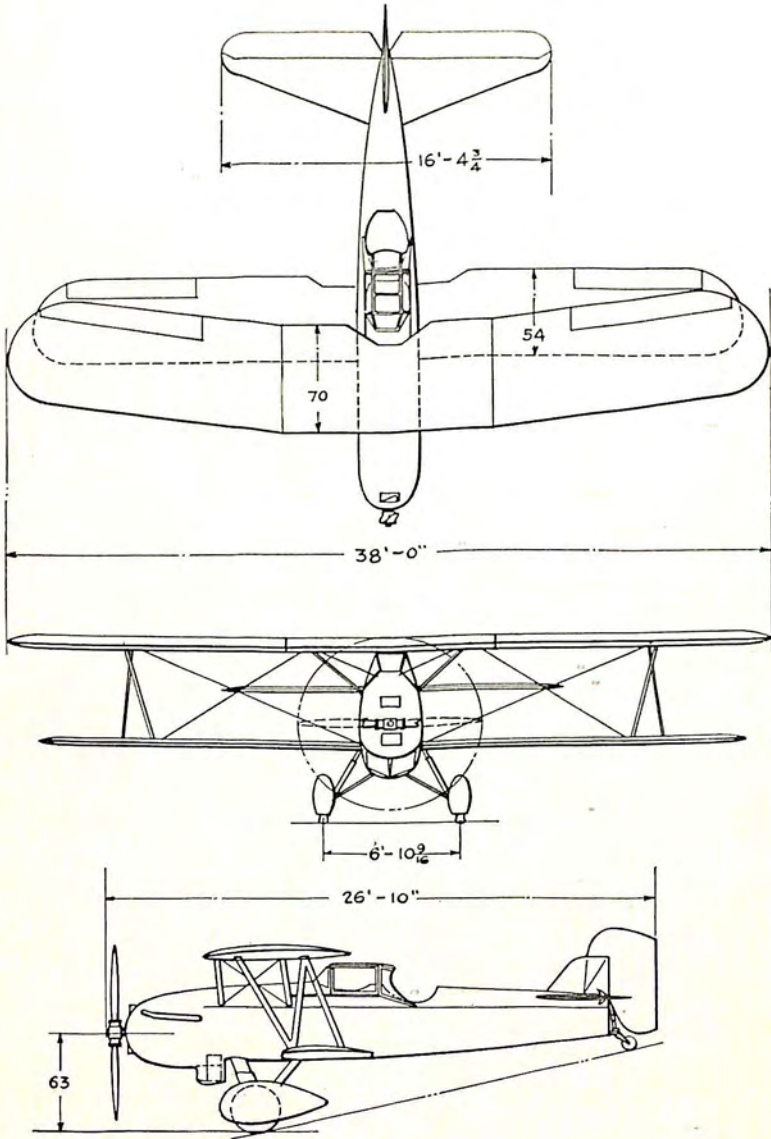

CURTISS AEROPLANE & MOTOR COMPANY,
 Buffalo, N. Y.
 OBSERVATION O-39
 ENGINE: CURTISS CONQUEROR

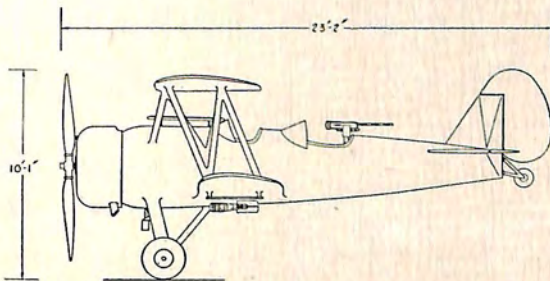
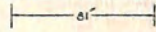
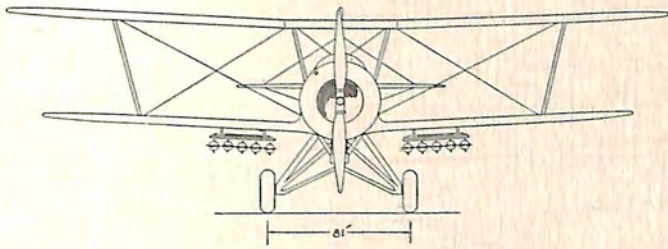
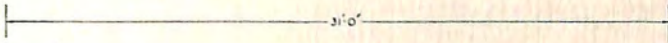
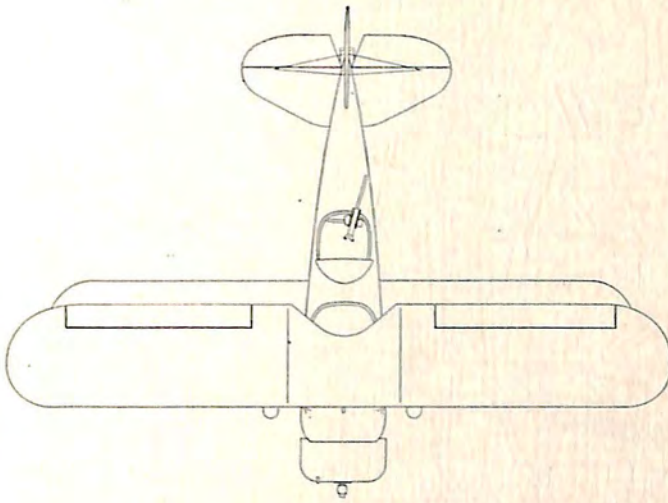

CURTISS-WRIGHT AIRPLANE COMPANY
St. Louis, Mo.

OSPREY — 2 PLACE
ENGINE: WRIGHT WHIRLWIND 420

MILITARY AIRPLANES

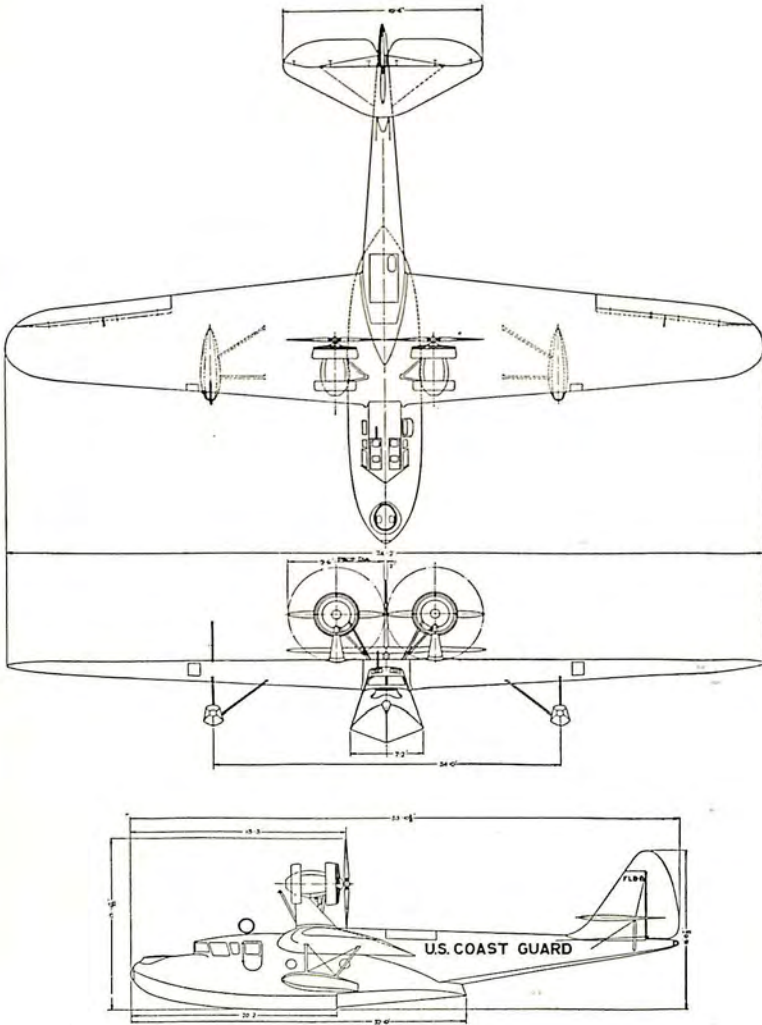

GENERAL AVIATION MANUFACTURING COMPANY
Dundalk, Md.
MODEL FLB
ENGINES: 2 PRATT & WHITNEY WASPS

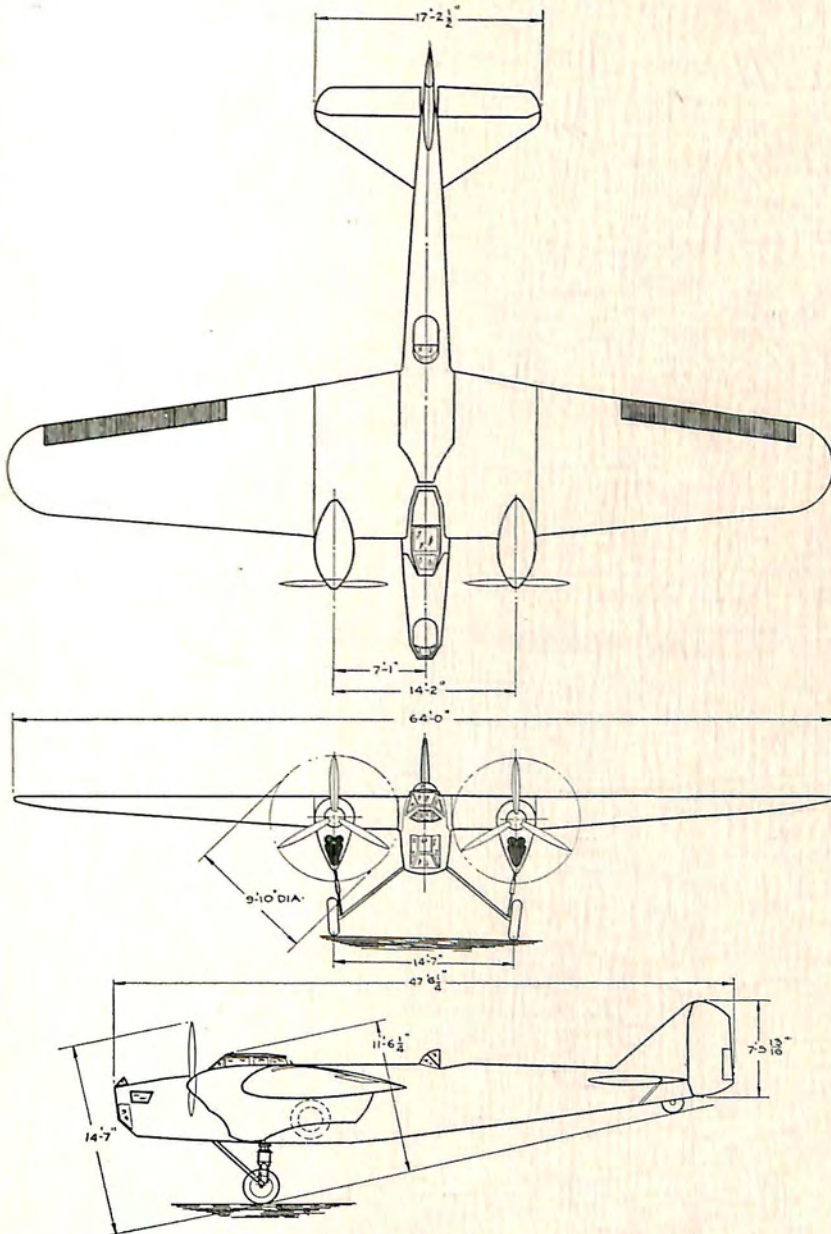

GENERAL AVIATION MANUFACTURING COMPANY
 Dundalk, Md.
 OBSERVATION YO-27
 ENGINE: TWO CURTISS CONQUERORS

MILITARY AIRPLANES

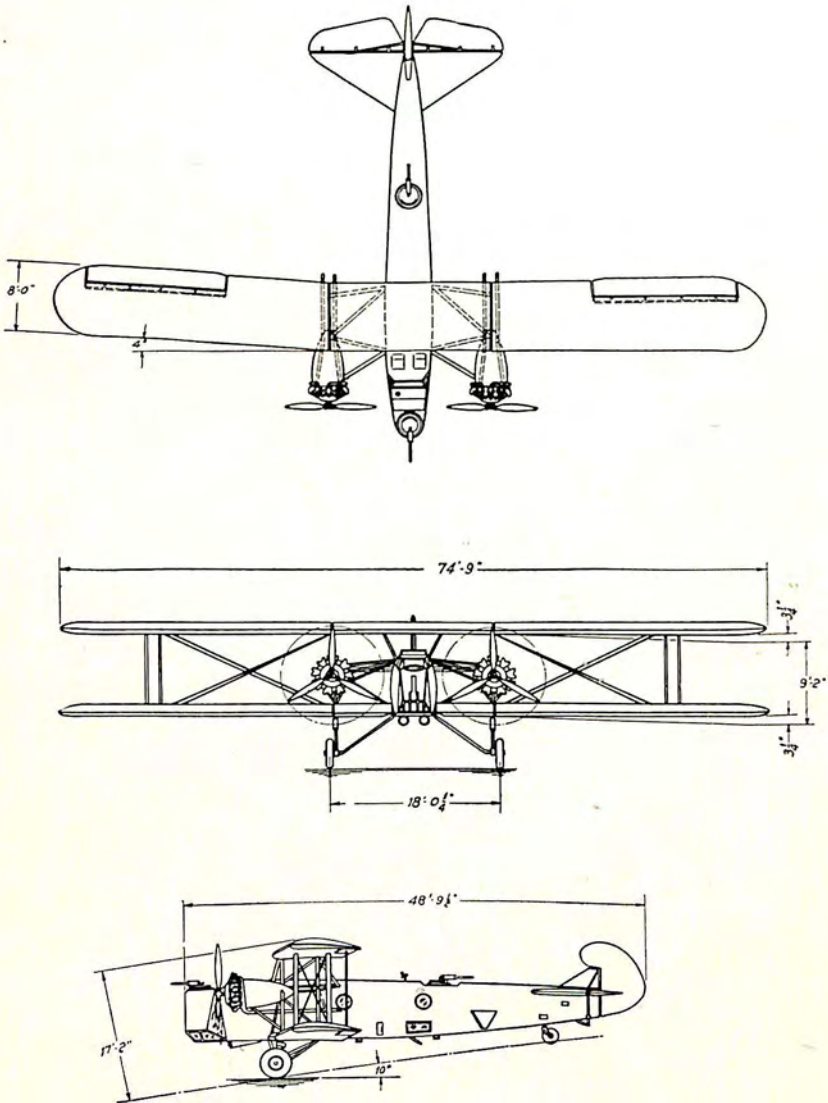

KEYSTONE AIRCRAFT CORPORATION
Bristol, Pa.

MODEL B4-A — B6-A

ENGINE: TWO PRATT & WHITNEY HORNETS
TWO WRIGHT CYCLONES

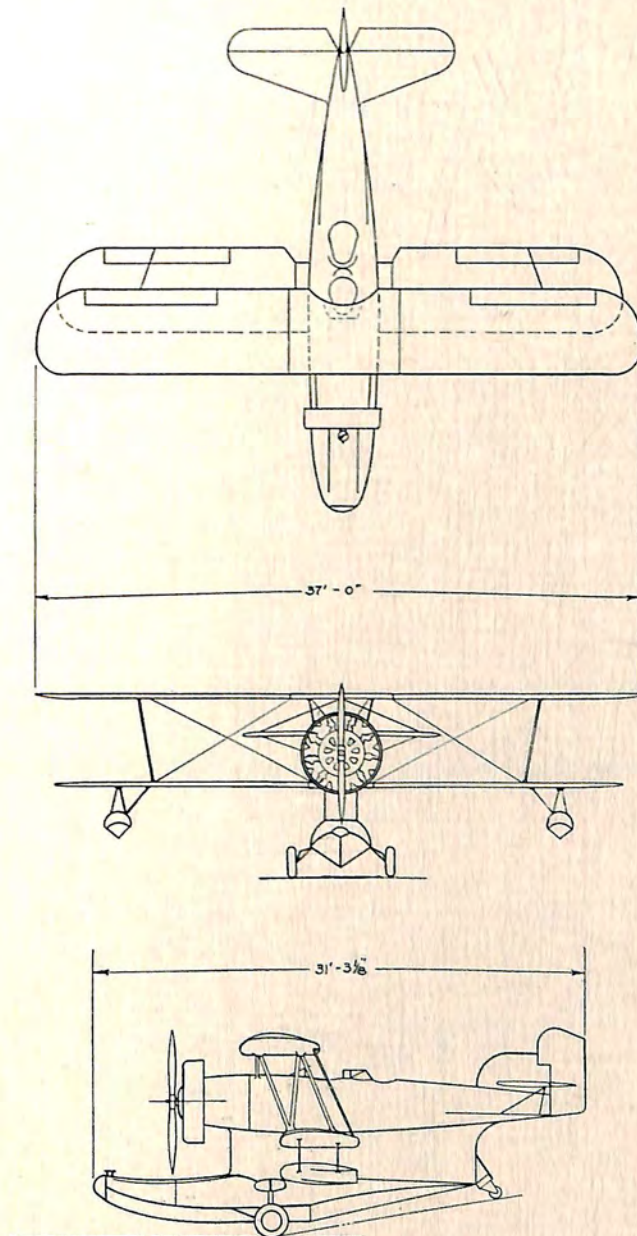

KEYSTONE AIRCRAFT CORPORATION
Bristol, Pa.
OBSERVATION O2L
ENGINE: PRATT & WHITNEY WASP

MILITARY AIRPLANES

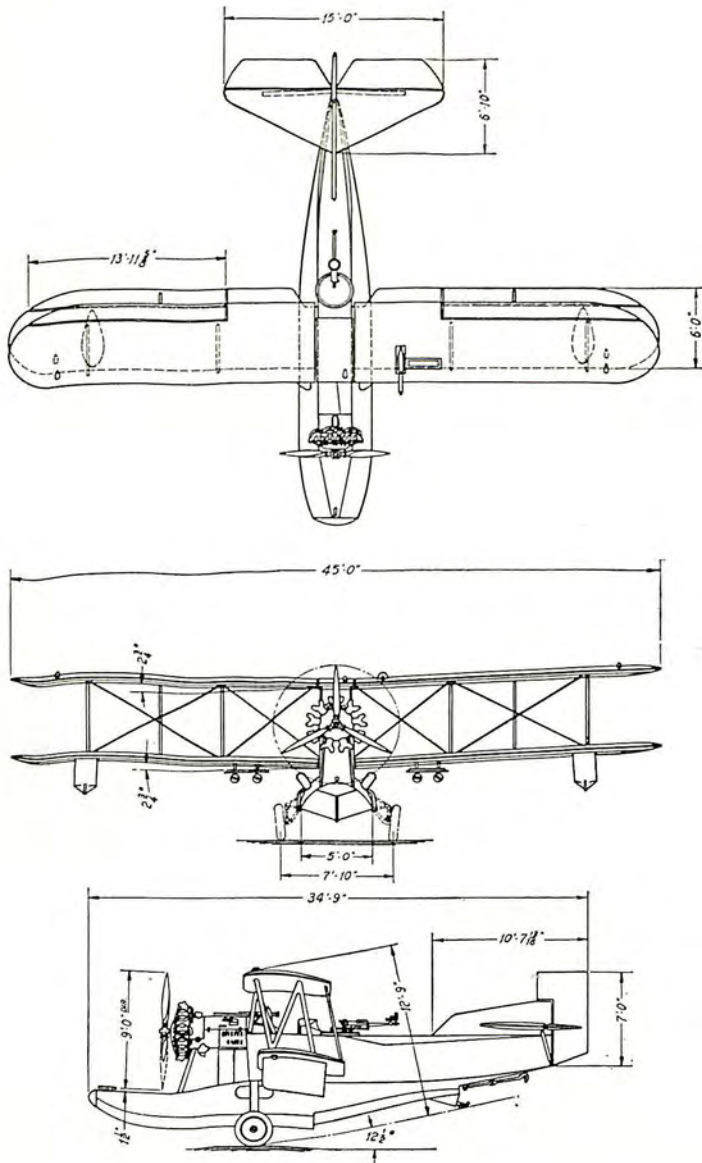

KEYSTONE AIRCRAFT CORPORATION
 Bristol, Pa.
 MODEL OL-9
 ENGINE: PRATT & WHITNEY WASP

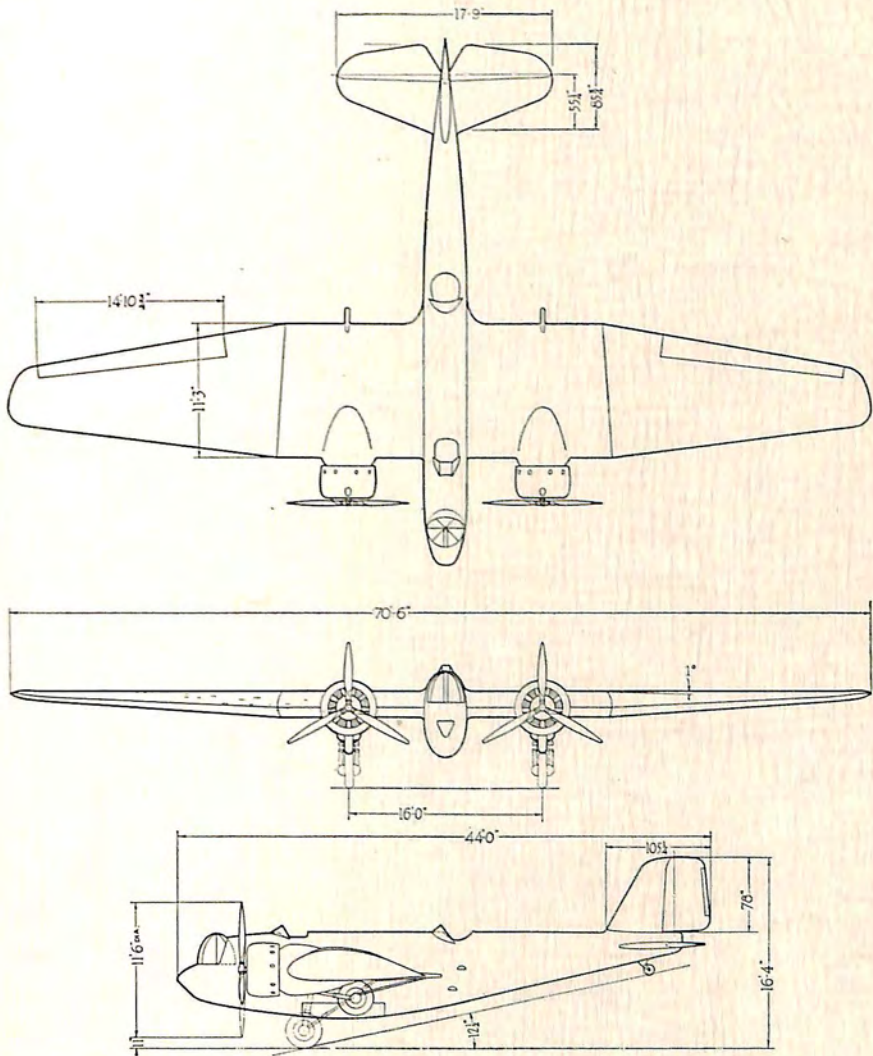

THE GLENN L. MARTIN COMPANY
 Baltimore, Md.
 BOMBER XB-907
 ENGINE: TWO GEARED WRIGHT CYCLONES

MILITARY AIRPLANES

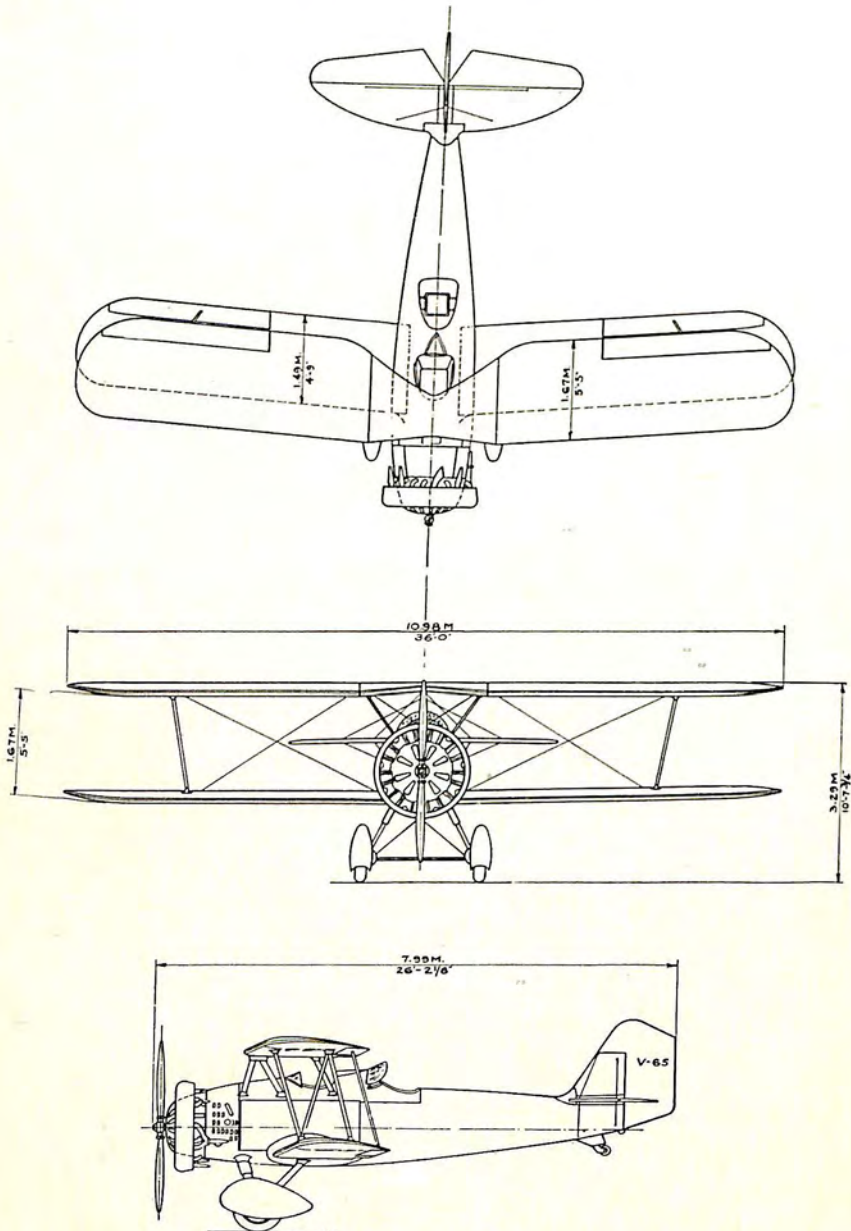

CHANCE VOUGHT CORPORATION
East Hartford, Conn.

MODEL V-65

ENGINE: PRATT & WHITNEY HORNET

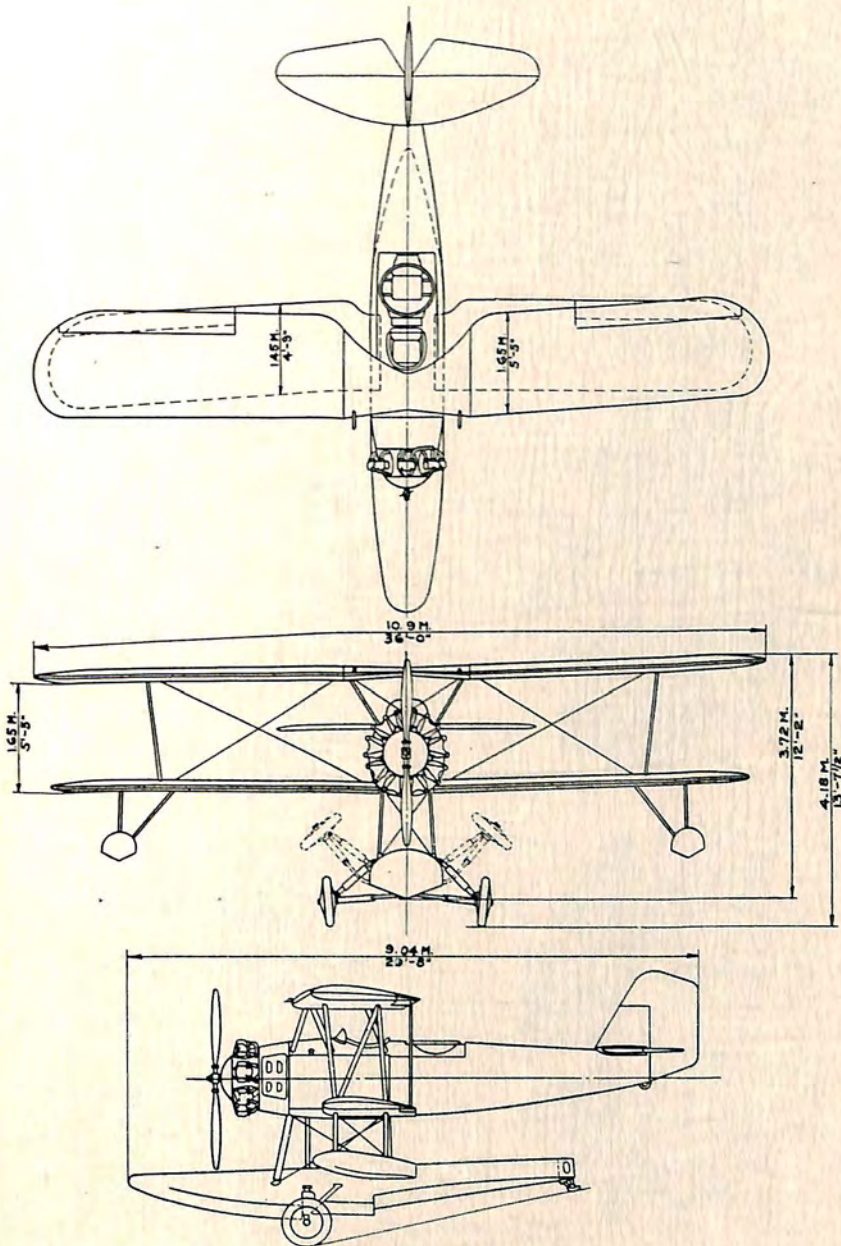

CHANCE VOUGHT CORPORATION
 East Hartford, Conn.
 OBSERVATION O2U-4
 ENGINE: PRATT & WHITNEY WASP

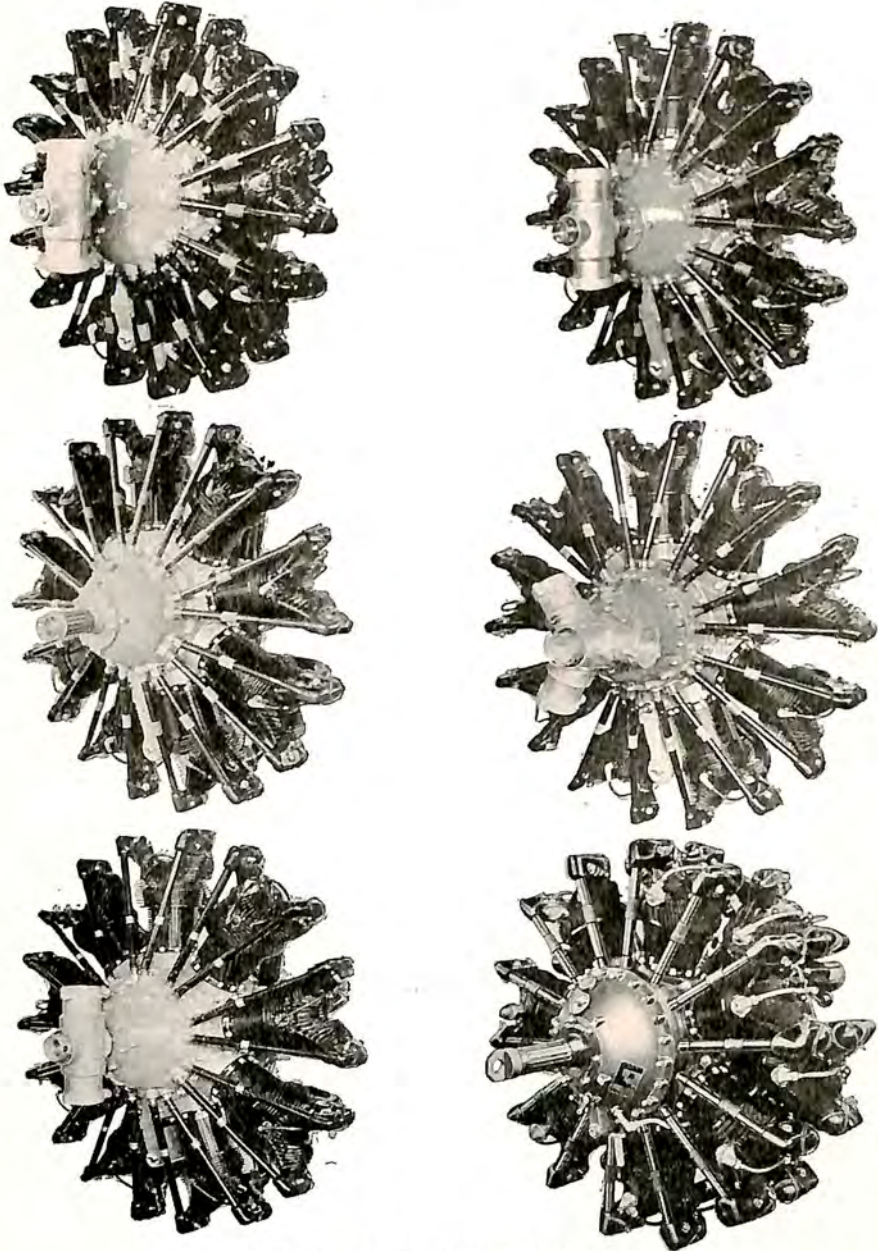

PRATT AND WHITNEY ENGINES

Wasp Junior, 300-420 horsepower (upper left); Wasp, 420-550 horsepower (upper right); Hornet Series B1, 575-625 horsepower (center left); Hornet Series B1 Geared, 575-600 horsepower (center right); Hornet Series C, 575-700 horsepower (lower left); and Twin Wasp Junior, 625 horsepower (lower right).

CHAPTER XIX

ADVANCES IN AMERICAN AIRCRAFT ENGINES

New Engines For 1933 Incorporate Many New Refinements—Two-Row Radial Engines Introduced—Weight-Horsepower Ratio Reduced—Frontal Area Cut—Higher Grade Fuels Used—Reviews Of Major Factories

ENGINE manufacturers in the United States entered 1933 with new models in production, or ready to be put into production, which combined lower weight and greater horsepower with less frontal area than ever had been offered the aircraft designer to aid in increasing the performance of new aircraft. The progress made during 1932 in the field of engine design accounted in a large measure for the increased speed and performance afforded 1933 aircraft designs, particularly in the transport and military fields.

The trend toward reducing the weight-horsepower ratio by constant "stepping-up" of power continued, being effected chiefly through the use of higher compression ratios, supercharging and operating at greater crankshaft speeds. Definite steps forward were achieved in the development of two-row radial air-cooled engines, providing greater horsepower with a minimum of frontal area, and in the gearing of higher speed engines. Experimental work on the problem of direct fuel injection was carried forward with good results during 1932, and several leading engine designers predicted that it would not be long before the carburetor, with its attendant troubles, would be a thing of the past. The reduction of engine noise was being attacked with renewed vigor, although little in the way of usable results had been obtained. Several companies were at work on the muffler problem, along with research at the Bureau of Standards, but it appeared that the installation of adequate mufflers would entail a very considerable item of added resistance as well as weight. Research also showed that the problem of muffling was one of permitting expansion, cooling and reduction of velocity in the exhaust gases, and that the volume necessary in the muffler was almost in direct proportion to the horsepower.

As an indication of the progress made in the reduction of weight per horsepower, it was only necessary to compare 1933 designs, which ap-

proached weights as low as one pound per horsepower, with those of a few years earlier. The aircraft engine, almost since its inception, has marked a new era in the development of power plants employing the internal combustion principle. The engine used by the Wright brothers on their first flights, although very crude, weighed less per horsepower than combustion engines in production at that time. Few manufacturers at the turn of the century considered possible an engine combining low weight with adequate horsepower such as the Wrights desired. The Wrights' first engine weighed approximately 16.6 pounds per horsepower. Most engines in production in 1933 approximated two pounds per horsepower and some of the newest designs approached one pound per horsepower.

The importance of developing and making generally available to the aircraft manufacturer and operator uniformly high-grade petroleum products was forcefully demonstrated by the progress made in further increasing the power outputs of standard aircraft engines. The Fuels and Lubricants Section of the Aeronautical Chamber of Commerce considered this problem as one of the most important on its program for the year. The higher powered engines required higher grades of fuel and oil because of the necessity for preventing detonation and because of greater bearing pressures and higher cylinder temperatures. The urgency of arranging for the widespread distribution of such products was self-evident with distances diminishing in the face of higher aircraft speeds and the world-wide use of aircraft becoming more important daily. The larger oil companies with affiliations already established throughout the world were in a position to render important service through use of their distribution facilities. Perhaps the most extensive work of this nature had been undertaken by the Stanavo Specification Board, Inc., which through the resources of its member companies, reached every world market of importance in aviation.

Introduction by both the Pratt and Whitney Aircraft Company and Wright Aeronautical Corporation of two-row 14 cylinder radial air-cooled engines of 625 horsepower marked one of the year's outstanding achievements in aircraft engine progress. Built to specification of the United States Navy and developed with the cooperation of the Bureau of Aeronautics, both engines weighed approximately 1.3 pounds per horsepower and had the smallest frontal area ever attained in a radial air-cooled engine of their rated power output. The Wright development was known as the Whirlwind R-1510, while the Pratt and Whitney designs were called the Twin Wasp Junior R-1535, and the Twin Wasp R-1830.

The new 14 cylinder Wright Whirlwind, despite increased horsepower, had the same five inch bore, the same 5.5 inch stroke, and the same overall diameter of 45 inches that the seven cylinder Whirlwind required. The

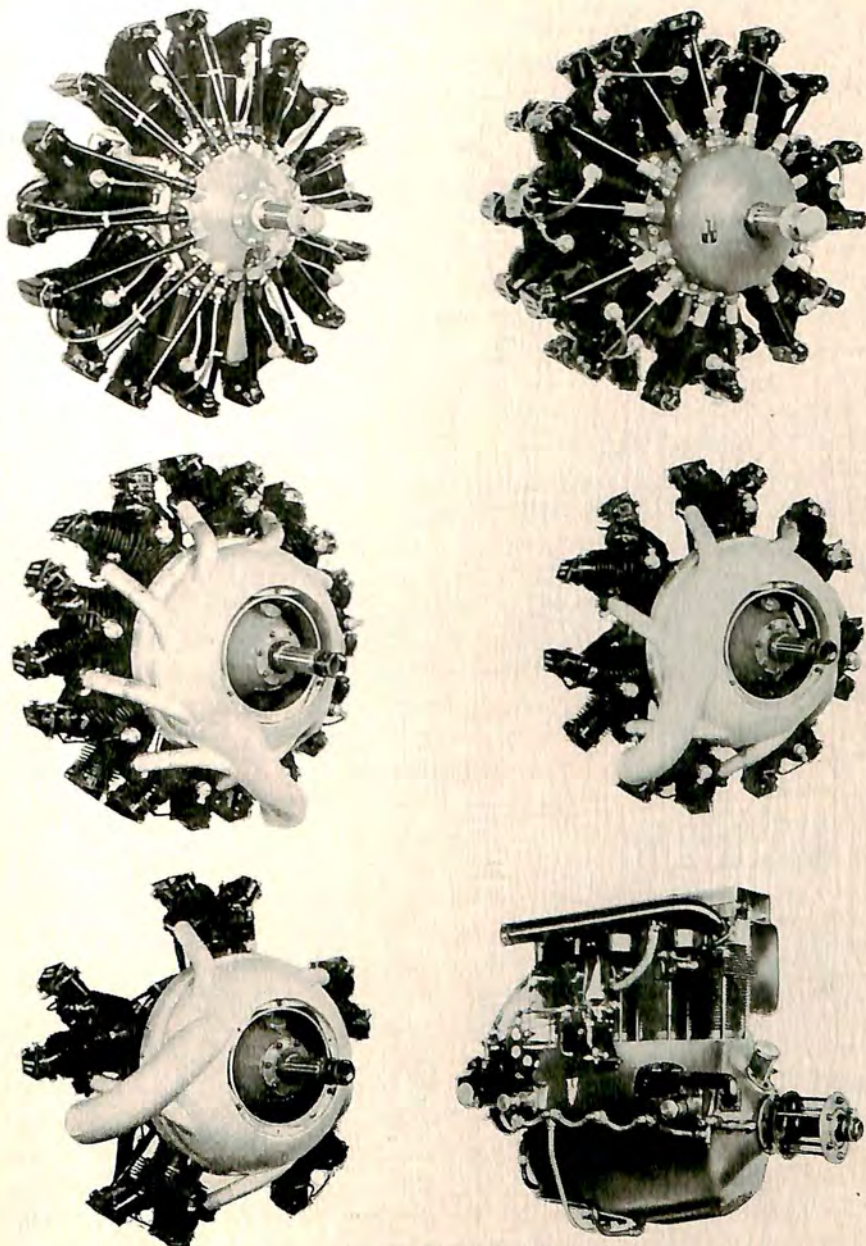

WRIGHT ENGINES

Cyclone F, 700 horsepower (upper left); 14 Cylinder Whirlwind, 625 horsepower (upper right); Whirlwind, 330, 365 and 420 horsepower (center left); Whirlwind 250 and 280 horsepower (center right); Whirlwind, 175 horsepower (lower left); and Gipsy, 90 horsepower (lower right).

low frontal area afforded the pilot with excellent forward vision and considerably reduced drag, factors of particular importance in single engine tractor installations. The design and construction of the new engine's major parts were very much similar to the new Wright Cyclone F, later described, and rated at 700 horsepower at 1,900 revolutions per minute. Particularly in the design of the cylinder head, supercharger and rear section there was a marked similarity to corresponding parts of the Cyclone. Other unique features were a main crankcase forged in three sections, a single induction system feeding both front and rear cylinders, an ingenious system of baffling to insure maximum cooling to the cylinders, a two throw crankshaft forged from one piece, and a new type of master rod. As a direct drive engine, the 14 cylinder Whirlwind weighed only 837 pounds.

Pratt and Whitney's new Twin Wasp Junior R-1535 developed 625 horsepower at 2,100 revolutions per minute. Equipped with a three-to-two propeller reduction gear, the R-1535 had a power output of 700 horsepower. The Twin Wasp R-1830, a larger engine than the R-1535 but constructed along the lines of identical engineering principles, produced 675 horsepower as a direct drive engine and was capable of approximately 800 horsepower when equipped with a three-to-two propeller reduction gear.

The lowest weight per horsepower yet attained in a production engine model was achieved in another new design introduced during 1932, the Wright Cyclone R-1820-F. It weighed only 1.22 pounds per horsepower, and was a nine cylinder radial air-cooled engine rated at 700 horsepower at 1,900 revolutions per minute. Supplementing the Cyclone E, the new engine was designed for an 87 octane fuel. Unique features of the model were a new design cylinder head with spark plug coolers cast integral and fins spaced more closely together, the substitution of alloys of superior physical qualities over those previously used, redesign of the mounting section to improve installation in the airplane, modification of the accessory section to improve its accessibility and extensive changes made in the supercharger, which included the use of an impeller 11 inches in diameter compared with the seven inch impeller on previous models.

Illustrative of the trend toward increased compression ratios was the new model introduced in 1932 by the Lycoming Manufacturing Company, the R-680-BA. It was similar to the model that preceded it, the R-680, in that it also was a nine cylinder radial air-cooled engine with the same bore and stroke, but its compression ratio was 6.5 to 1 as compared to 5.3 to 1 on the earlier model. The new engine developed 240 horsepower at 2,000 revolutions per minute as compared with 215 horsepower at the same engine speed in the other model. New features included an improved fin design arranged to increase the cooling area, both around the body of the cylinder head as well as the spark plug bosses. The enclosure around the spark plugs was cast integral with the head and provided clean radio

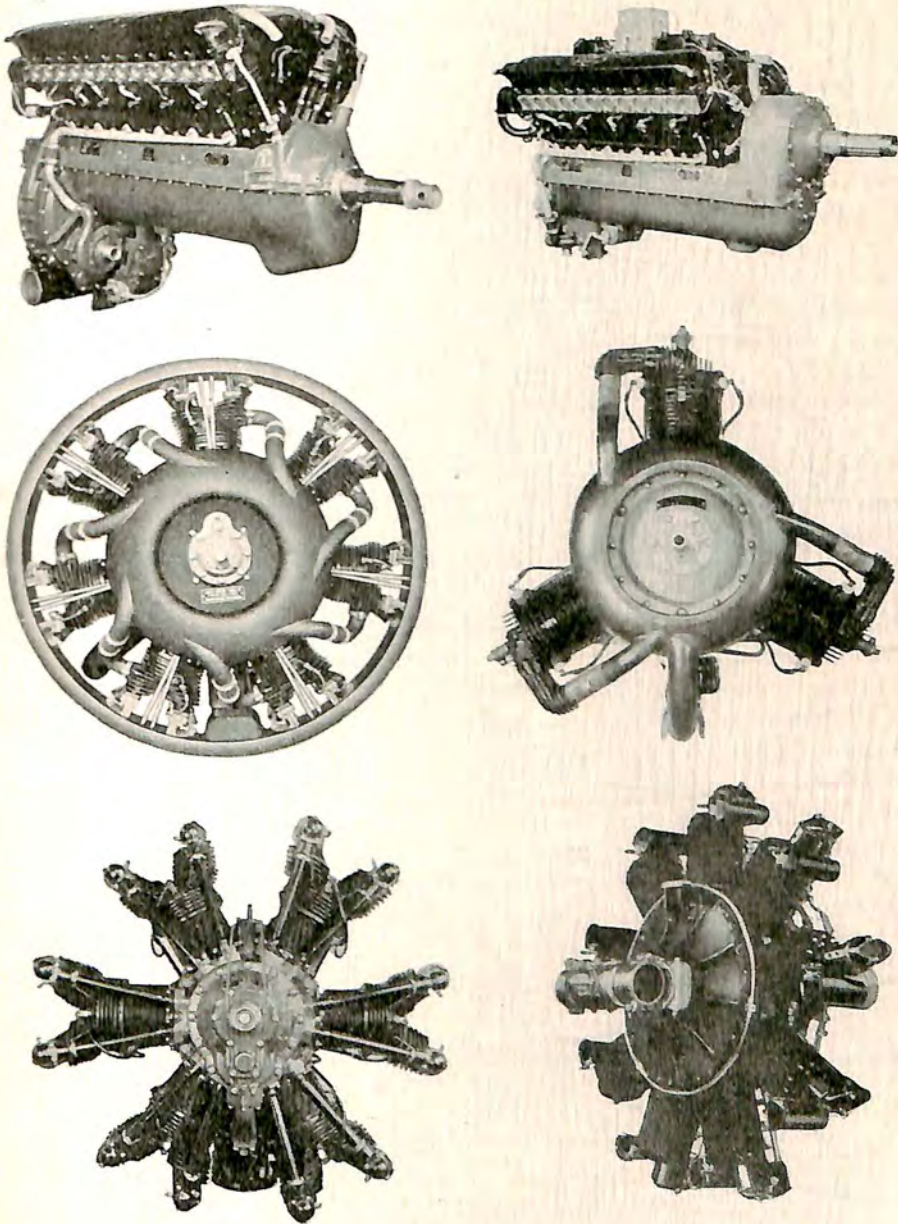

WRIGHT, JACOBS AND PACKARD ENGINES

Curtiss Super-Conqueror, 600 horsepower (upper left); Curtiss Geared Conqueror, 625 horsepower (upper right); Jacobs LA-1, 170 horsepower (left center); Jacobs L-3, 55 horsepower (right center); Curtiss Challenger, 185 horsepower (lower left); and Packard Diesel, 225 horsepower (lower right).

shielding installation. The new engine was primarily for transport service and an 80 octane fuel was necessary.

The demand for higher horsepower rating also caused the Pratt and Whitney Aircraft Company to announce early in 1932 a complete series of new engines, which will be described later in this chapter under the heading of that company's activities. The Wright Aeronautical Corporation also obtained higher power output ratings on practically all of its models during the early fall of 1932. In fact most of the major engine manufacturers were in production on models for 1933 with substantially higher horsepower ratings, including the Continental Aircraft Engine Company, Jacobs Aircraft Engine Company, Kinner Airplane and Motor Corporation, and Warner Aircraft Corporation in addition to those already named. Their models will be described later in this chapter.

While the call for increased horsepower, particularly for military and transport airplanes, overshadowed developments in the low-powered engine field, there were some interesting developments in that field. With lack of real stimulus from the private low-powered market, developments in engines of small horsepower could not be expected to be spectacular. Nevertheless, such companies as the Aeronautical Corporation of America, Continental Aircraft Engine Company, Jacobs Aircraft Engine Company and Warner Aircraft Corporation made improvements in their small engines ranging from 35 to 90 horsepower.

Advances in aircraft engine designs naturally necessitated certain changes in the Department of Commerce Engine Requirements. These changes were discussed and agreed upon through a joint conference of officials of the Department of Commerce and the Engine Manufacturers' Section of the Aeronautical Chamber of Commerce. The Engine Manufacturers' Section also worked closely with the Fuels and Lubricants Section on the problem of standardization of octane ratings for aircraft fuels.

A brief résumé of the year's activities in each of the major engine manufacturing plants which were actually in production or carried on interesting experimental work during 1932 should provide a fair picture of the developments in the power plant field and the types of products offered for both the commercial and military markets. The manufacturers are arranged in alphabetical order for convenience in future reference.

Aeronautical Corporation of America, with its plant in Cincinnati, O., supplemented the Aeronca E-113 with a modified type designated as the E-113A, a two cylinder opposed air-cooled engine rated at 36 horsepower at 2,400 r.p.m.

Allison Engineering Company of Indianapolis, Ind., a division of General Motors, continued its experimental work for the Army and Navy. The design and construction of the propeller drive units for the "U.S.S. Macon," the Navy's new airship, was one of the principal projects

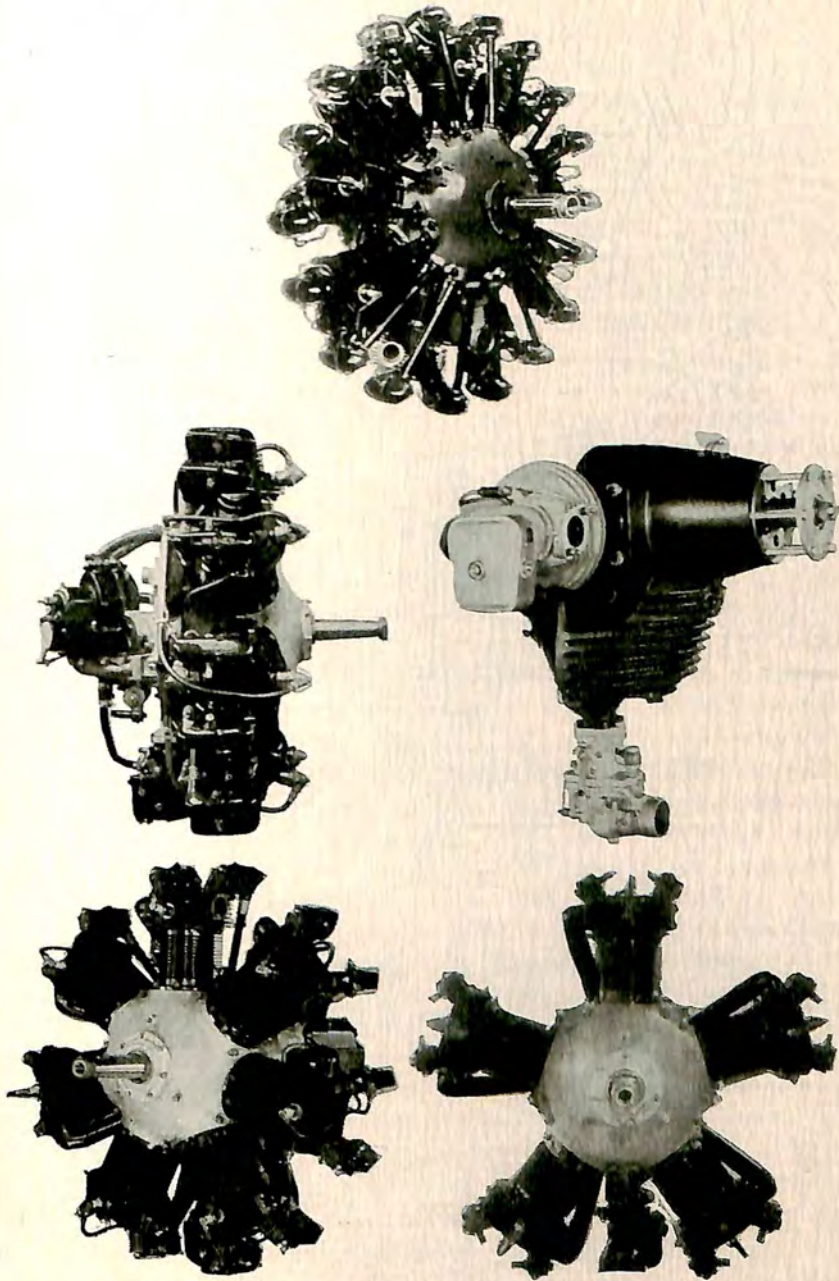

LYCOMING, WARNER AND AERONCA ENGINES

Lycoming R-680-BA, 240 horsepower (top); Warner Super-Scarab, 145 horsepower (left center); Aeronca E-113A, 36 horsepower (right center); Warner Scarab, 110 horsepower (lower left); and Warner Scarab, Jr., 90 horsepower (lower right).

of the year. The drive units were similar to those used on the "U.S.S.Akron," also designed by Allison. Bronze lined steel backed bearings, an exclusive development of the company, are standard on most aircraft engines produced in the United States and abroad.

American Airplane and Engine Corporation of Farmingdale, N. Y., a division of the Aviation Corporation, developed its series of inverted in-line 12 cylinder air-cooled engines designated as the Ranger V-770, developing 270 horsepower; the V-770-G, 300 horsepower; the V-770-S, 325 horsepower; and the V-770-SG, 340 horsepower.

Continental Aircraft Engine Company of Detroit, Mich., a division of Continental Motors, increased the power output of its A-70-2 engine, a seven cylinder radial air-cooled model, to 215 horsepower. A geared engine was produced for the Army, and the A-40, a four cylinder horizontally opposed air-cooled L head engine designed to develop 35 horsepower at 2,500 r.p.m., was continued on the market.

Jacobs Aircraft Engine Company of Pottstown, Pa., moved its main plant and offices from Camden, N. J., to Pottstown, continuing the Camden plant as a service base. Fifty thousand square feet of floor space was occupied in the Pottstown plant, which continued production of the LA-1, a seven cylinder radial air-cooled engine rated at 170 horsepower; the LA-2, a seven cylinder radial air-cooled engine rated at 195 horsepower; and the L-3, a three cylinder radial air-cooled engine rated at 55 horsepower.

Kinner Airplane and Motor Corporation, Ltd., of Glendale, Cal., continued production of the Kinner K-5, B-5, and C-5, all of them five cylinder radial air-cooled engines rated at 100, 125 and 210 horsepower, respectively. An Approved Type Certificate also was received on a new design, the Kinner R-5, a five cylinder radial air-cooled engine rated at 160 horsepower at 1,975 r.p.m. The company also designed and produced a two-place side-by-side open monoplane powered with Kinner engines.

The Lycoming Manufacturing Company of Williamsport, Pa., a division of the Cord Corporation, introduced a new model designated as the R-680-BA, some features of which already have been described. It was a nine cylinder radial air-cooled engine rated at 240 horsepower at 2,000 r.p.m., using 80 octane fuel and especially designed for air transport operation. The exhaust outlets of the new engine were so arranged that the cylinders could be exhausted to the rear as well as the front of the engine, depending upon the installation. The new model supplemented the R-680, a nine cylinder radial air-cooled engine rated at 215 horsepower at 2,000 r.p.m.

Monocoupe Corporation of Robertson, Mo., continued production of its R-266, a five cylinder radial air-cooled engine rated at 90 horsepower at 2,375 r.p.m.

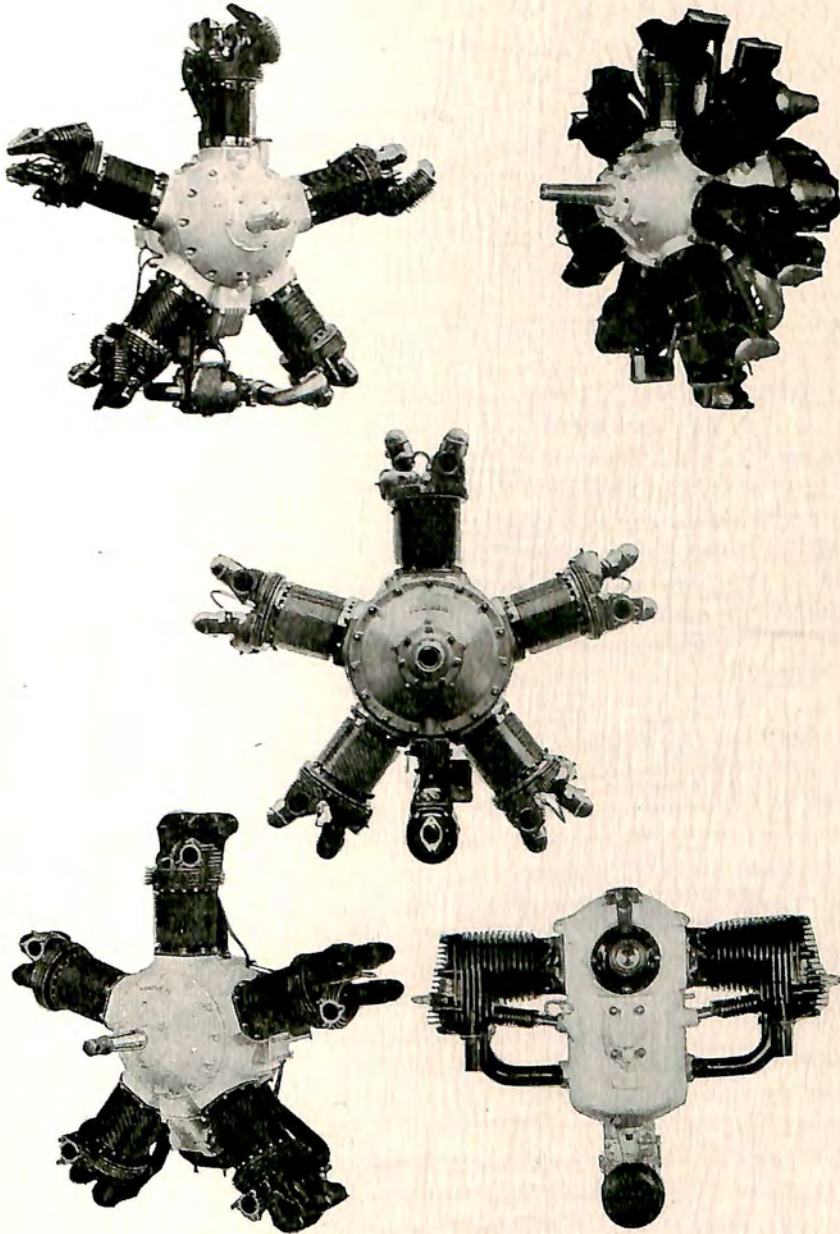

KINNER AND CONTINENTAL ENGINES

Kinner K-5, 100 horsepower (upper left); Continental A-70-2, 215 horsepower (upper right); Kinner C-5, 210 horsepower (center); Kinner R-5, 160 horsepower (lower left); and Continental A-40, 35 horsepower (lower right).

Packard Motor Car Company of Detroit, Mich., continued production and development of its Diesel aircraft engine, a nine cylinder radial air-cooled compression ignition oil burning engine, rated at 225 horsepower at 1,950 r.p.m. This engine, described in detail in "The Aircraft Year Book for 1932," was awarded the Collier Trophy as the outstanding development in American aviation during the previous year. The company continued development of the Packard 2500, a 12 cylinder V type water-cooled engine originally designated for 770 horsepower, but increased to 1,600 horsepower through the employment of supercharging and increased engine speed. Maximum power output was developed at 2,600 r.p.m., an increase of 600 revolutions over the original rate. Roots type superchargers were used in combination with four duplex down-draft carburetors to raise the power output to this new high point. Oil-cooled exhaust valves and the through hold-down stud bolts which extend from the cylinder flanges through the crankcase webs to the main bearing caps were two of the interesting design features. The through hold-down bolts, in effect, type the crankcase to the cylinders relieving the crankcase of the explosion stresses. During 1932, Packard licensed the firm of K. Walter and Company in Prague to manufacture Diesel engines. Tests were in progress in several other European countries, which considered acquisition of manufacturing licenses on the Packard Diesel.

The Pratt and Whitney Aircraft Company of East Hartford, Conn., a division of United Aircraft and Transport Corporation, introduced a new model power plant, the 14 cylinder two-row radial air-cooled engine, of which the Twin Wasp Junior R-1535 was the first announced. Rated at 625 horsepower at 2,100 r.p.m., the features of this outstanding new development are described earlier in this chapter. Equipped with a three-to-two propeller reduction gear, the R-1535 had a power output of 700 horsepower. The Twin Wasp R-1830, a larger engine than the R-1535 but constructed along identical lines, also was introduced in 1932. In its direct drive form, it produced 675 horsepower and, equipped with a three-to-two propeller reduction gear, it was capable of approximately 800 horsepower. A complete new series of Wasp and Hornet engines, all carrying substantially increased horsepower ratings, was introduced early in 1932. These improved models were of the nine cylinder single-row radial air-cooled type and embodied all basic Pratt and Whitney principles. The Wasp Junior, smallest of the series, was available with horsepower ratings ranging from 300 to 420. The Wasp Junior Series A was rated at 300 horsepower at 2,000 r.p.m. at sea level; Series S2A at 375 horsepower at 2,200 r.p.m. at 7,500 feet; Series T3A at 420 horsepower at 2,200 r.p.m. at sea level. The Wasp, a larger engine with 1,344 cubic inch displacement, was available with horsepower ratings varying from 420 to 550. Wasp Series C1 was rated at 420 horsepower at 2,000 r.p.m. at sea level; Series SC1 at 450

horsepower at 2,100 r.p.m. at 6,000 feet; Series SD₁ at 500 horsepower at 2,200 r.p.m. at 7,500 feet; Series S₁D₁ at 525 horsepower at 2,200 r.p.m. at 5,000 feet; Series T₁D₁ at 500 horsepower at 2,100 r.p.m. at sea level; Series SE at 500 horsepower at 2,200 r.p.m. at 11,000 feet; Series S₁E at 500 horsepower at 2,200 r.p.m. at 9,000 feet; Series D₁ at 550 horsepower at 2,100 r.p.m. at sea level. These two latter models were for military purposes only. Wasp engines with five-to-four propeller reduction gears, Series C₁G and Series SD₁G, were available at 425 horsepower and 500 horsepower, respectively. The Hornet Series B₁ with a displacement of 1,860 cubic inches was rated from 575 to 625 horsepower. Hornet Series B₁ was rated at 575 horsepower at 1,950 r.p.m. at sea level; Series S₁B₁ at 575 horsepower at 1,950 r.p.m. at 6,000 feet; Series S₂B₁ at 575 horsepower at 1,950 r.p.m. at 8,000 feet; Series T₃B₁ at 625 horsepower at 1,950 r.p.m. at sea level. This same engine with a three-to-two propeller reduction gear bore a rating of 575 horsepower at 2,000 r.p.m. at 8,000 feet. For military purposes it also was available in its geared form at 600 horsepower at 6,000 feet. The Hornet Series C with a displacement of 1,690 cubic inches was offered in the following variations: Series C at 600 horsepower at 2,000 r.p.m. at sea level; Series S₁C at 575 horsepower at 2,000 r.p.m. at 5,000 feet; Series S₂C at 575 horsepower at 2,000 r.p.m. at 7,500 feet; and Series T₁C at 700 horsepower at 2,000 r.p.m. at sea level. A combination hotspot and oil temperature regulator as well as inter-cylinder deflectors were standard with all engines in the higher horsepower class.

Warner Aircraft Corporation of Detroit, Mich., continued production of the Warner Scarab, a seven cylinder radial air-cooled engine rated at 110 horsepower at 1,850 r.p.m. and the Scarab Junior, a five cylinder radial air-cooled engine rated at 90 horsepower at 2,025 r.p.m. Experimental production of a new model designated as the Super-Scarab, a seven cylinder radial air-cooled engine designed to develop 145 horsepower at 2,000 r.p.m., was completed. Early in 1932, Warner absorbed the Aircraft Products Corporation, thus adding to its line wheels, brakes, shock struts and skis for the commercial market.

Wright Aeronautical Corporation of Paterson, N. J., a division of the Curtiss-Wright Corporation, designed and produced an advanced Cyclone model designated as the R-1820-F, features of which already have been described, and introduced a 14 cylinder two-row radial air-cooled engine known as the R-1510, also described earlier. Both represented outstanding engineering progress in the field of high output power plants, combining high horsepower with low weight and a minimum of frontal area. The R-1510 developed 625 horsepower, while the Cyclone F was rated at 700 horsepower at 1,900 r.p.m., the latter supplementing the Cyclone E, a nine cylinder radial air-cooled engine rated at 575 horsepower at 1,900 r.p.m. In addition to the high performance Cyclone F model

designed for use with an 87 octane fuel, another model was offered to operate on the more widely obtainable 73 octane fuel and rated by the manufacturer at 600 horsepower at 1,900 r.p.m. with a normal maximum power output of 640 horsepower at rated crankshaft speed. Early in 1932, all models of the Whirlwind series were rated at higher outputs by the Department of Commerce. The nine cylinder model R-975E with a power output of 300 horsepower at 2,000 r.p.m. obtained an approved rating of 330 horsepower at the same engine speed, 365 horsepower at 2,100 r.p.m., and 420 horsepower at 2,150 r.p.m. Differences in compression ratios and degree of supercharging account for the several ratings. The seven cylinder model, formerly known as the Whirlwind 240 horsepower engine, was advanced with an approved power output of 250 horsepower at 2,000 r.p.m. and 280 horsepower at 2,150 r.p.m. The five cylinder model with a piston displacement of 540 cubic inches and former rating of 165 horsepower at 2,000 r.p.m. was advanced to 175 horsepower at 2,000 r.p.m. The Curtiss Conqueror series was developed to a point where both the geared and direct drive models might be operated with Prestone as the coolant, and a supercharged engine capable of carrying the rated power output of the direct drive Conqueror to an altitude of 12,000 feet was added to the Conqueror series. Three standard liquid-cooled models of 1,570 cubic inch displacement were offered: the direct drive Conqueror rated at 650 horsepower at 2,400 r.p.m.; the two-to-one geared Conqueror rated at 630 horsepower at 2,450 r.p.m.; and the seven-to-five geared Conqueror rated at 625 horsepower at 2,450 r.p.m. All three delivered, under normal conditions of temperature and pressure, in excess of 650 horsepower at rated speed. The Super-Conqueror was a liquid-cooled engine, similar in general design to standard Conquerors, but with a supercharger of the built-in centrifugal type housed at the rear of the engine and driven through a long hollow shaft which provided the required flexibility to remove shocks from the supercharger gears and bearings. The Wright Gipsy, a four cylinder in-line air-cooled engine rated at 90 horsepower at 1,950 r.p.m., and the Curtiss Challenger, a six cylinder radial air-cooled engine rated at 185 horsepower at 2,000 r.p.m., were offered to the commercial market. The engines were built in the modern plant at Paterson, N. J., having 630,000 square feet of floor space, and employing on November 1, 1932, nearly 1,400 persons.

Two-view drawings of the principal American engines developed or produced during 1932 are presented immediately following this chapter, in alphabetical order according to the name of the producer. Attention also is called to the three-view drawings of important aircraft types showing engine installation, immediately following the chapters on "Trends in American Aircraft Design," and to the performance tables on leading commercial aircraft types with their several available engine installations.

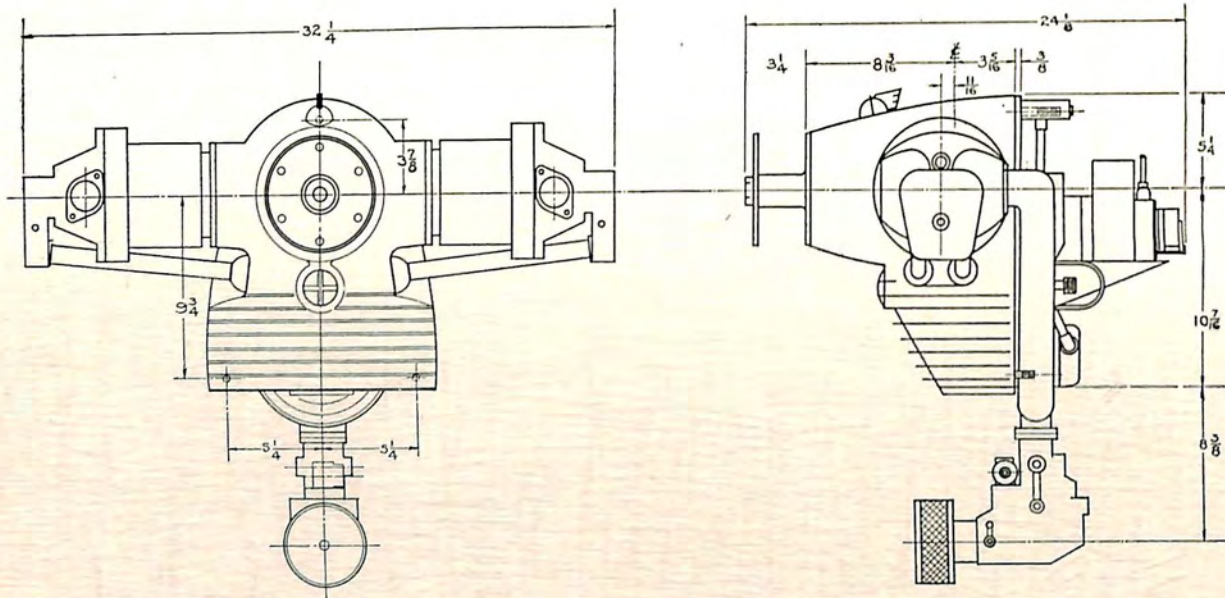

AERONAUTICAL CORPORATION OF AMERICA
Cincinnati, Ohio

AERONCA E-113A — 36 H.P.
2 CYLINDER OPPOSED AIRCOOLED

AIRCRAFT ENGINES

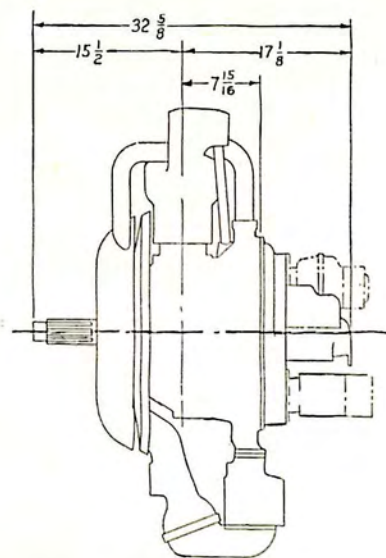
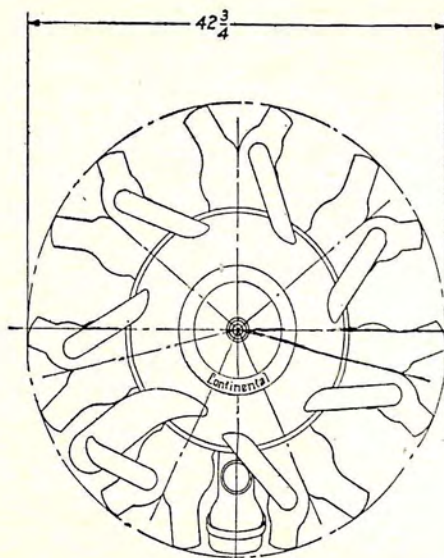

CONTINENTAL AIRCRAFT ENGINE COMPANY
Detroit, Mich.

MODEL R-690 — 215 H.P.
7 CYLINDER RADIAL AIRCOOLED

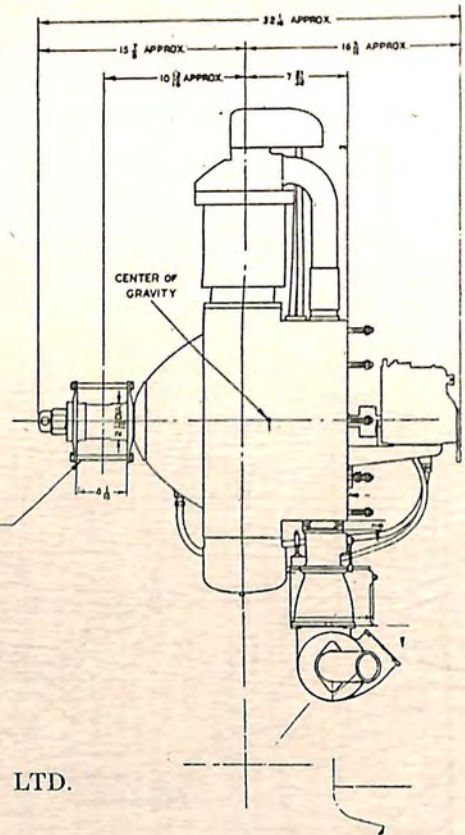
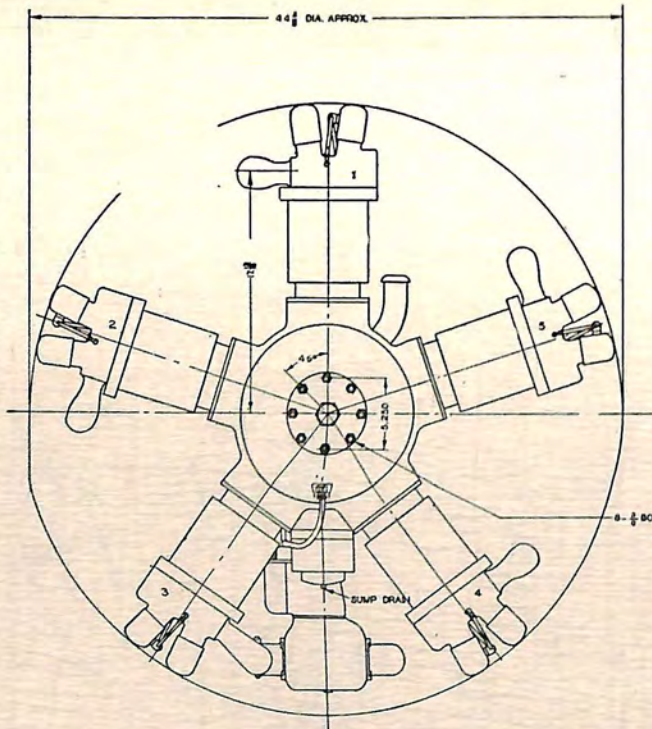

KINNER AIRPLANE & MOTOR CORPORATION, LTD.
Glendale, Calif.

MODEL K-5 — 100 H.P.
5 CYLINDER RADIAL AIRCOOLED

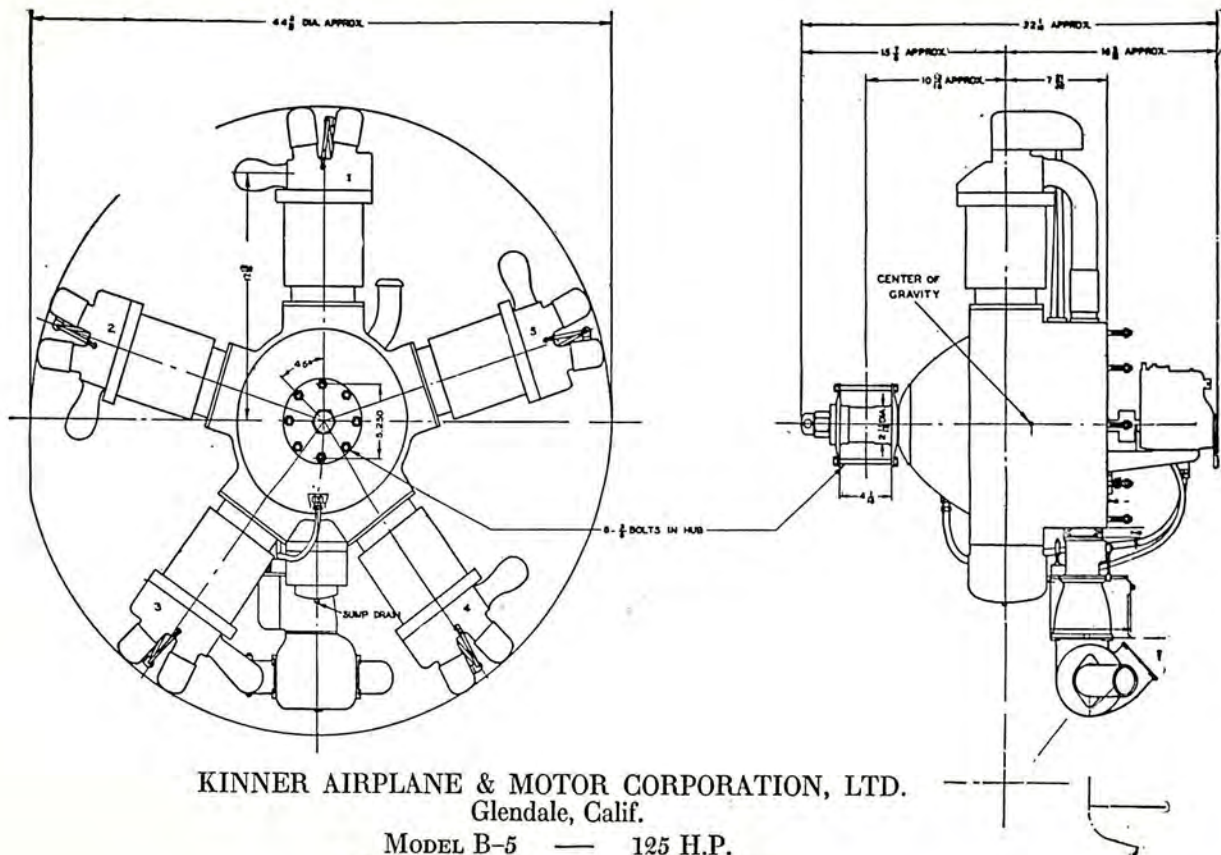

KINNER AIRPLANE & MOTOR CORPORATION, LTD.
 Glendale, Calif.

MODEL B-5 — 125 H.P.
 5 CYLINDER RADIAL AIRCOOLED

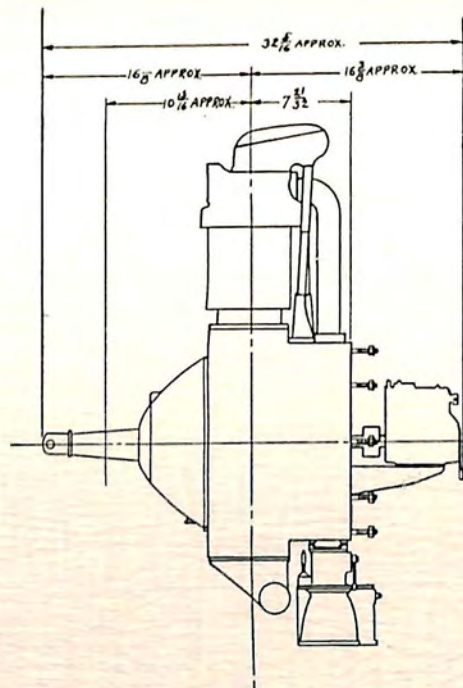
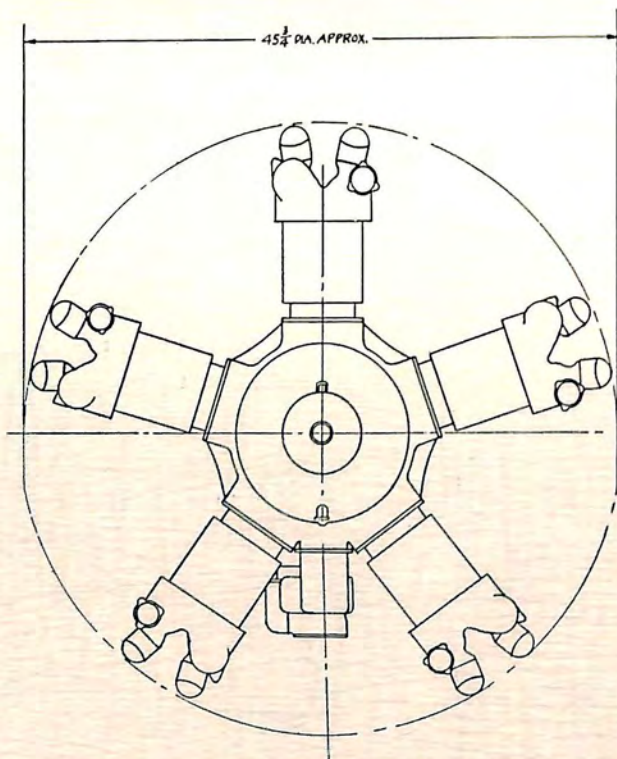

KINNER AIRPLANE & MOTOR CORPORATION, LTD.
Glendale, Calif.

MODEL R-5 — 160 H.P.
5 CYLINDER RADIAL AIRCOOLED

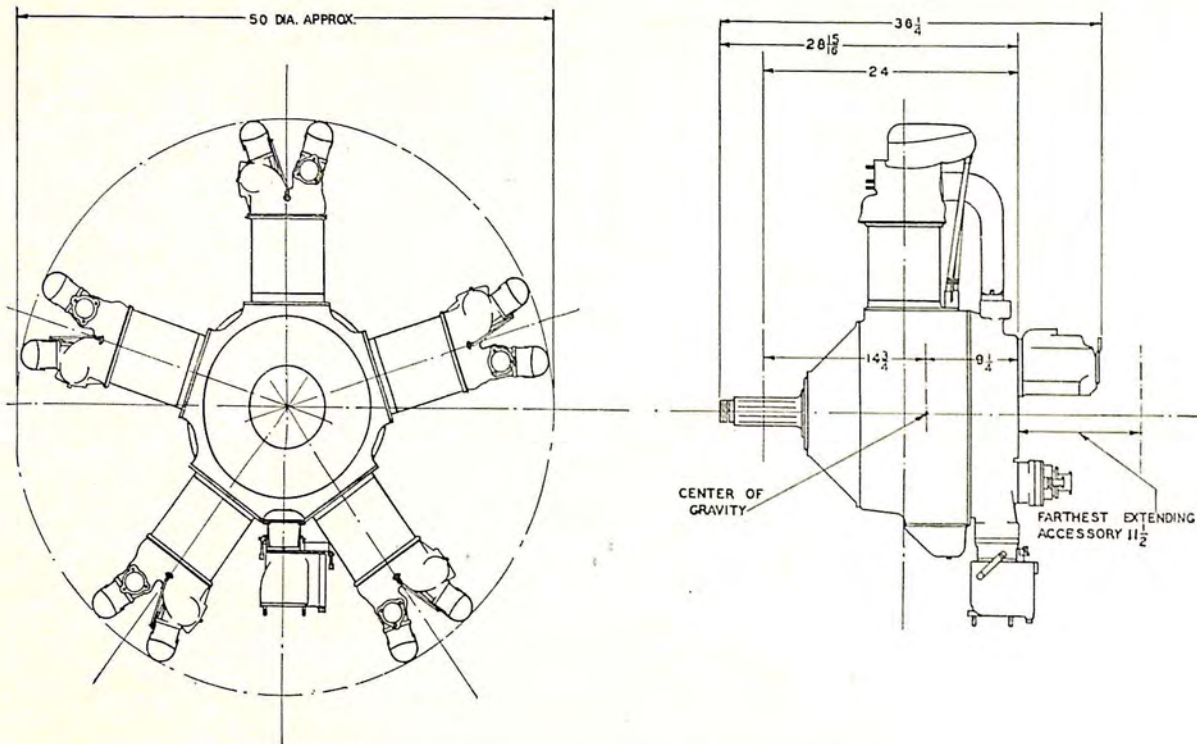

KINNER AIRPLANE & MOTOR CORPORATION, LTD.
 Glendale, Calif.
 MODEL C-5 — 210 H.P.
 5 CYLINDER RADIAL AIRCOOLED

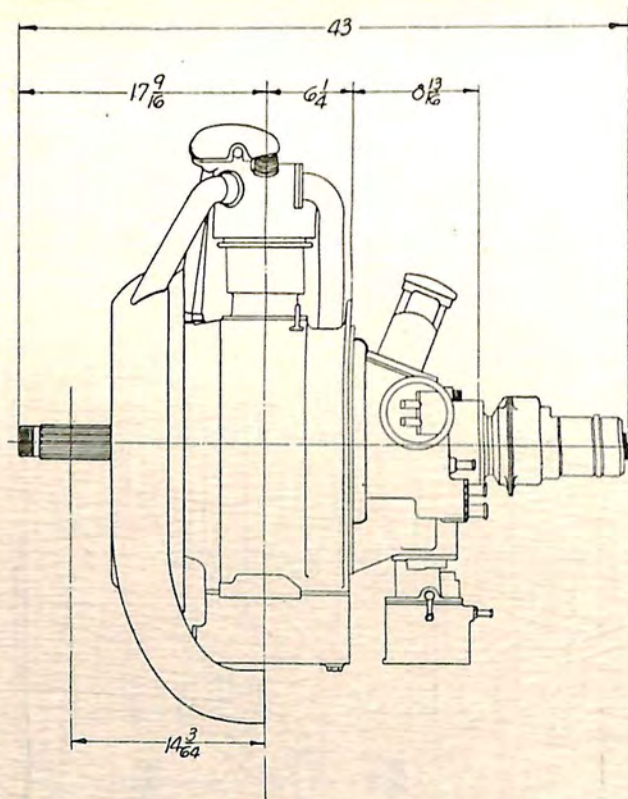
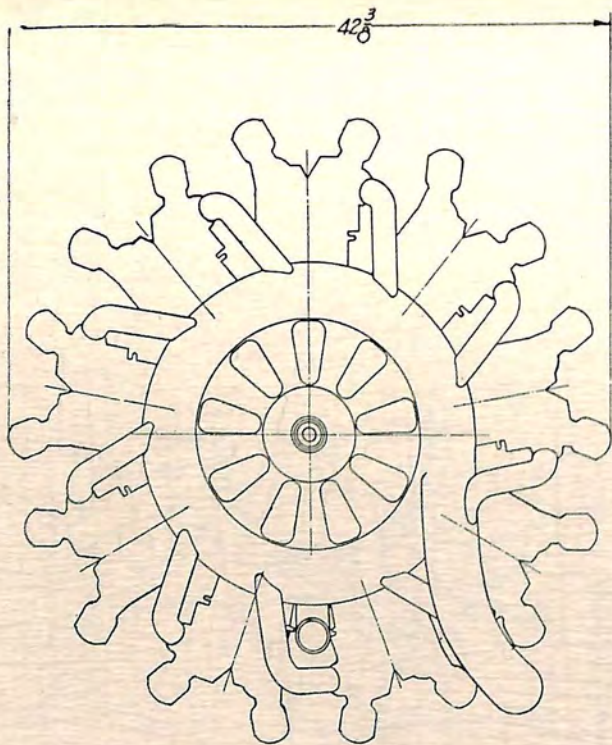

LYCOMING MANUFACTURING COMPANY
Williamsport, Pa.

MODEL R-680 — 215 H.P.
9 CYLINDER RADIAL AIRCOOLED

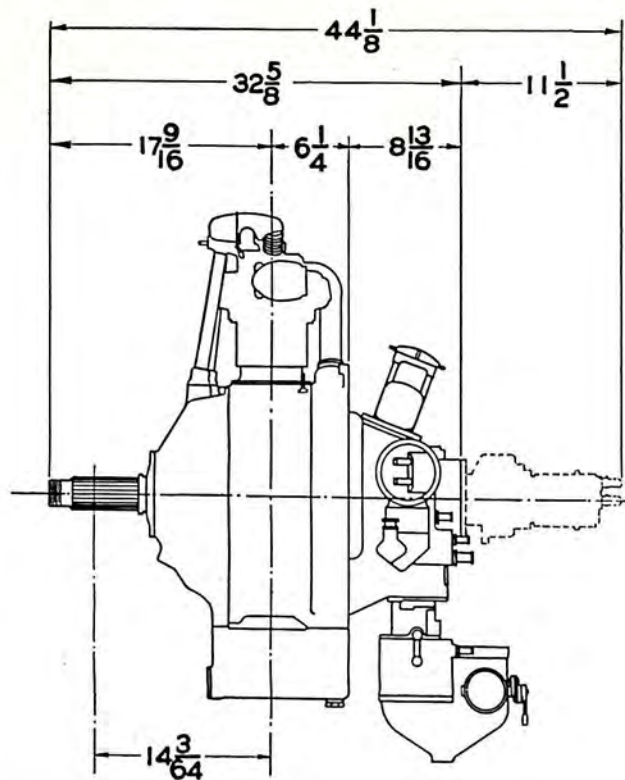
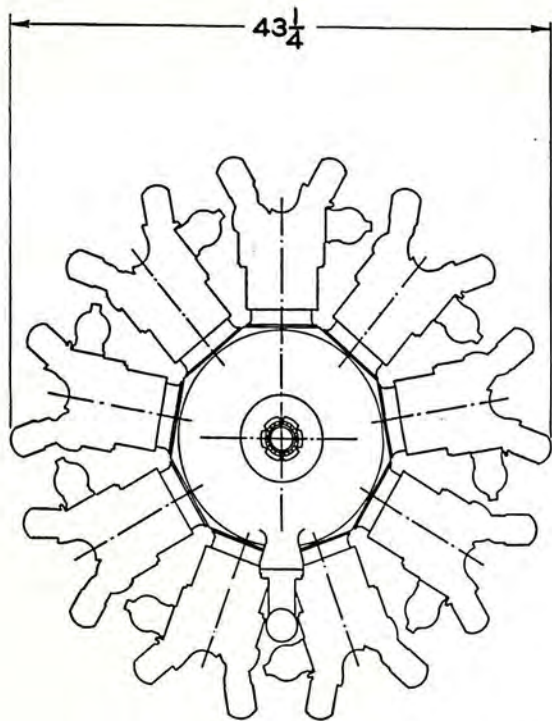

LYCOMING MANUFACTURING COMPANY
Williamsport, Pa.

MODEL R-680-BA — 240 H.P.
7 CYLINDER RADIAL AIRCOOLED

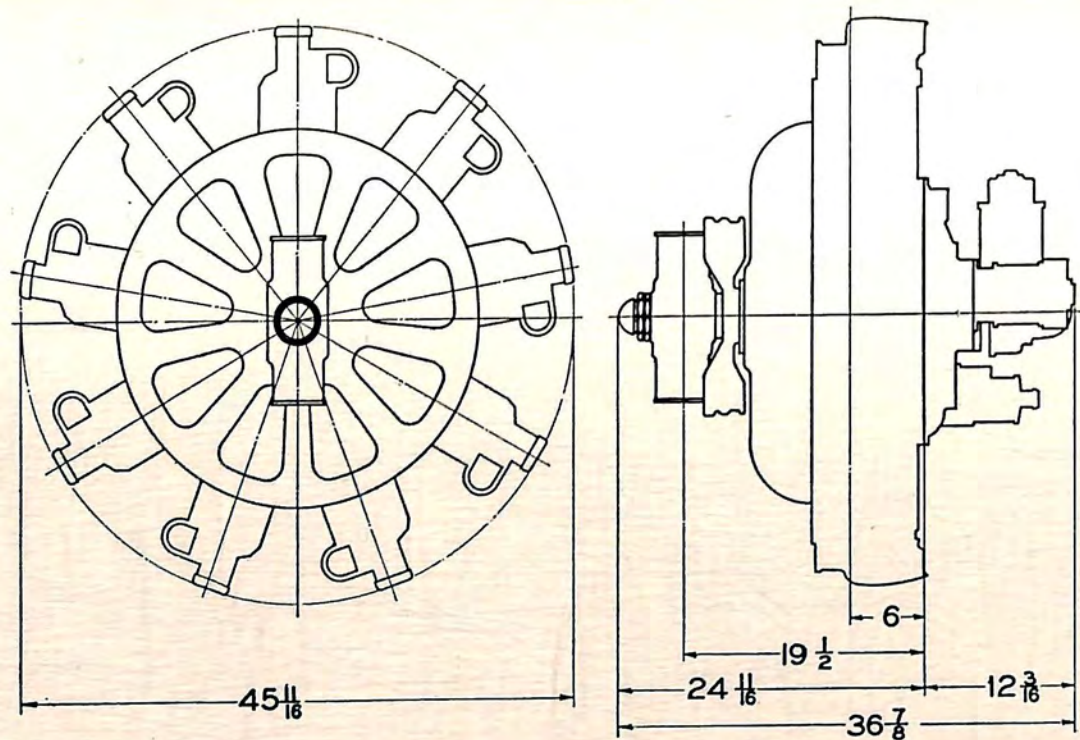

PACKARD MOTOR CAR COMPANY
 Detroit, Mich.
 MODEL DR-980 — 225 H.P.
 9 CYLINDER RADIAL AIRCOOLED

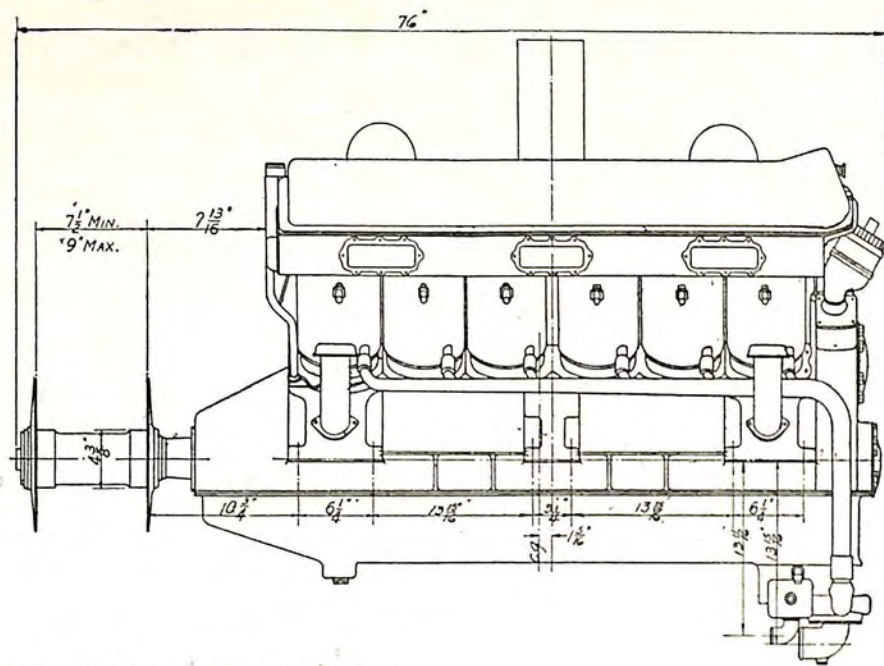
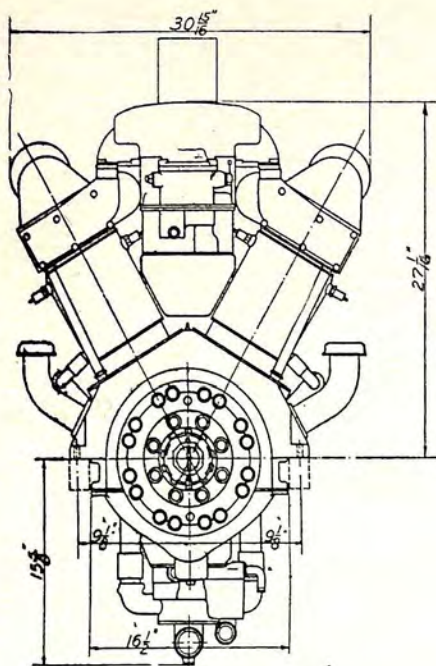

PACKARD MOTOR CAR COMPANY
 Detroit, Mich.
 MODEL 2500 — 1600 H.P.
 12 CYLINDER V TYPE WATERCOOLED

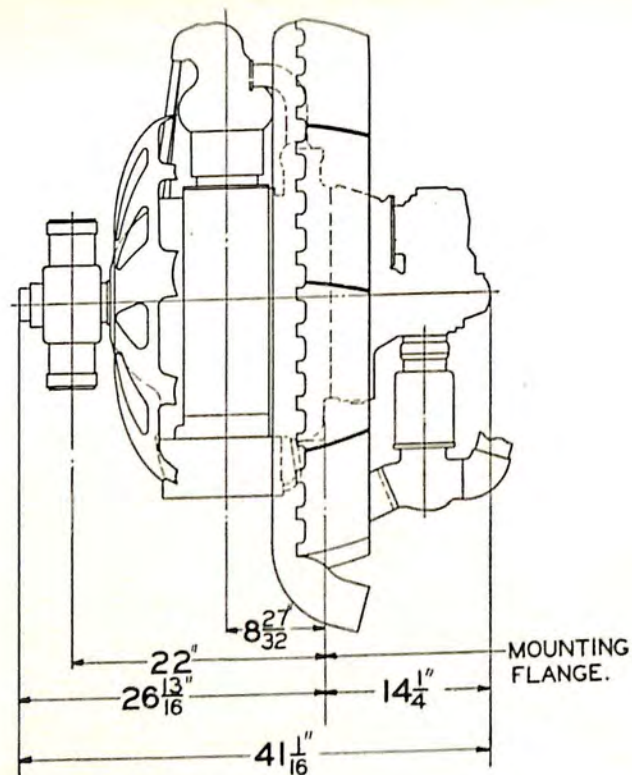
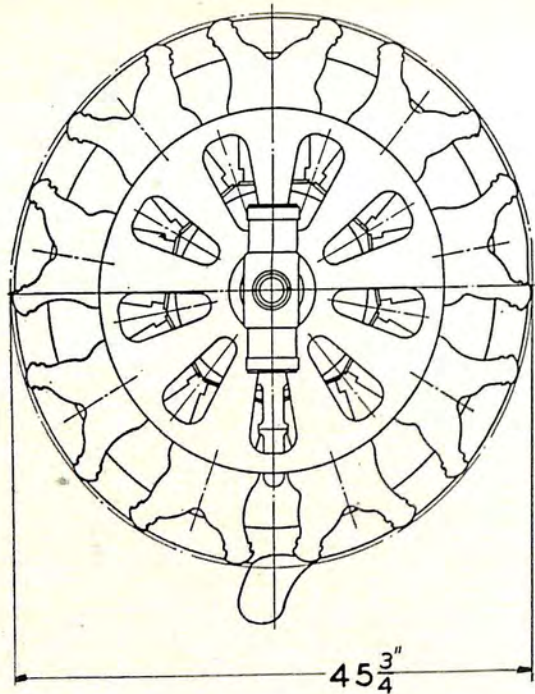

PRATT & WHITNEY AIRCRAFT COMPANY
East Hartford, Conn.

WASP JR. — 300-420 H.P.
9 CYLINDER RADIAL AIRCOOLED

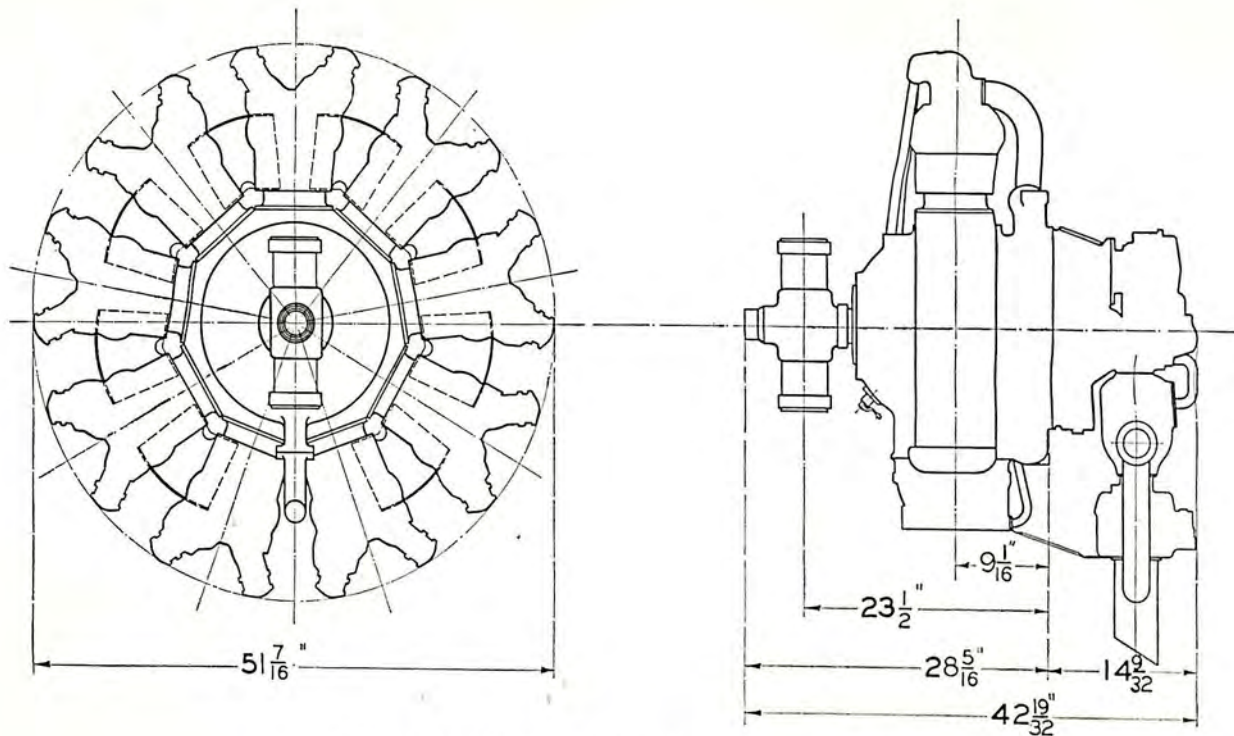

PRATT & WHITNEY AIRCRAFT COMPANY
East Hartford, Conn.

WASP — 420-550 H.P.

9 CYLINDER RADIAL AIRCOOLED

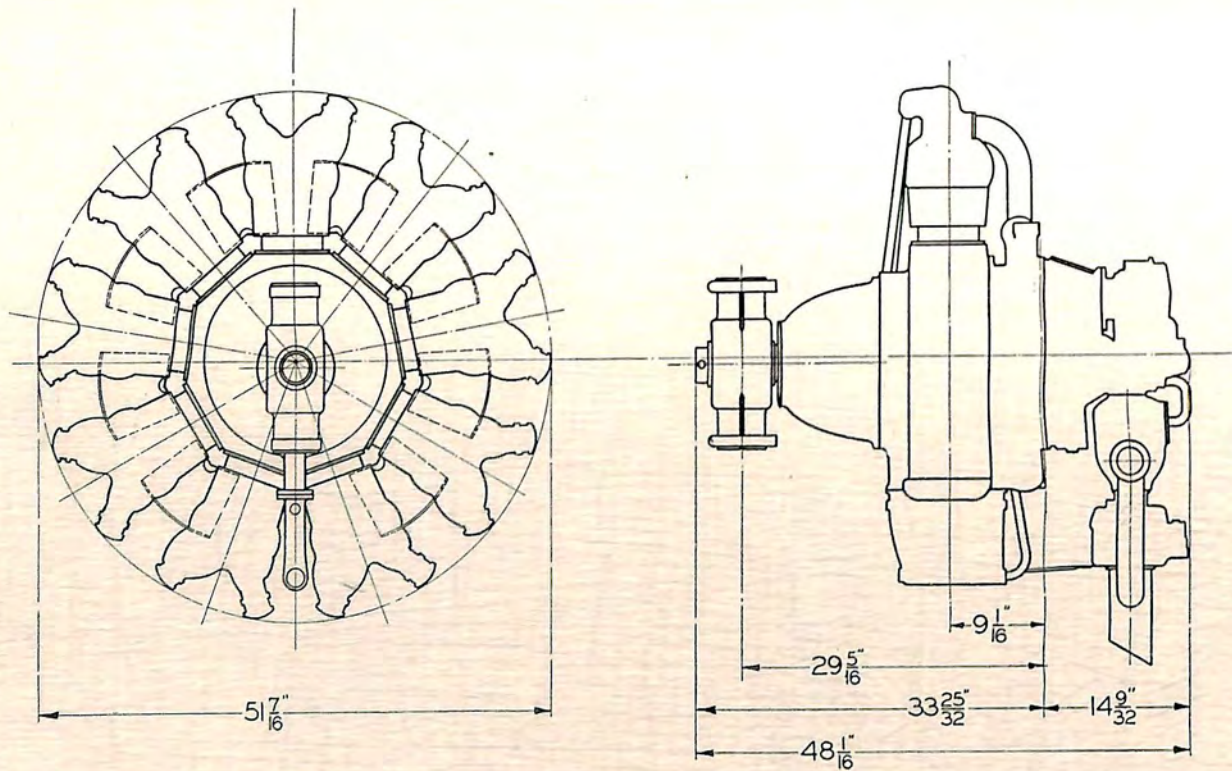

PRATT & WHITNEY AIRCRAFT COMPANY
 East Hartford, Conn.

WASP (GEARED 5 : 4) — 425-500 H.P.
 9 CYLINDER RADIAL AIRCOOLED

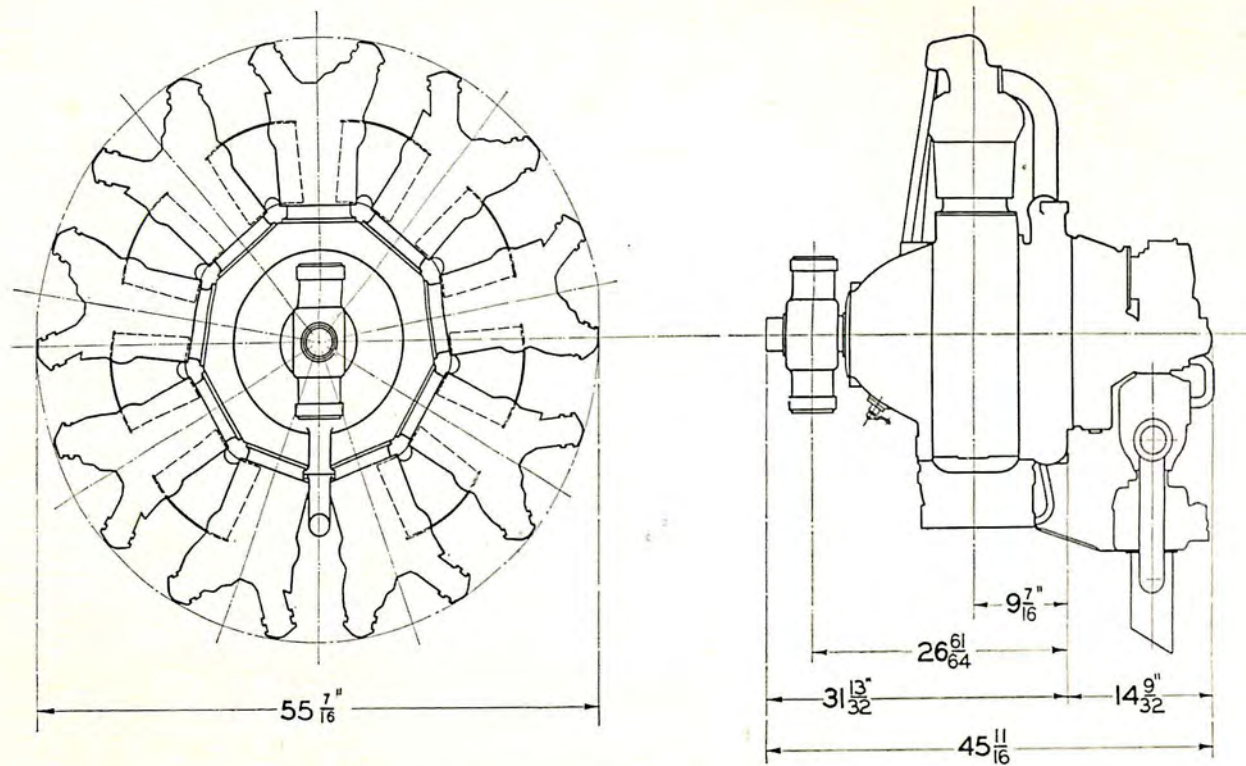

PRATT & WHITNEY AIRCRAFT COMPANY
East Hartford, Conn.

HORNET C — 575-700 H.P.
9 CYLINDER RADIAL AIRCOOLED

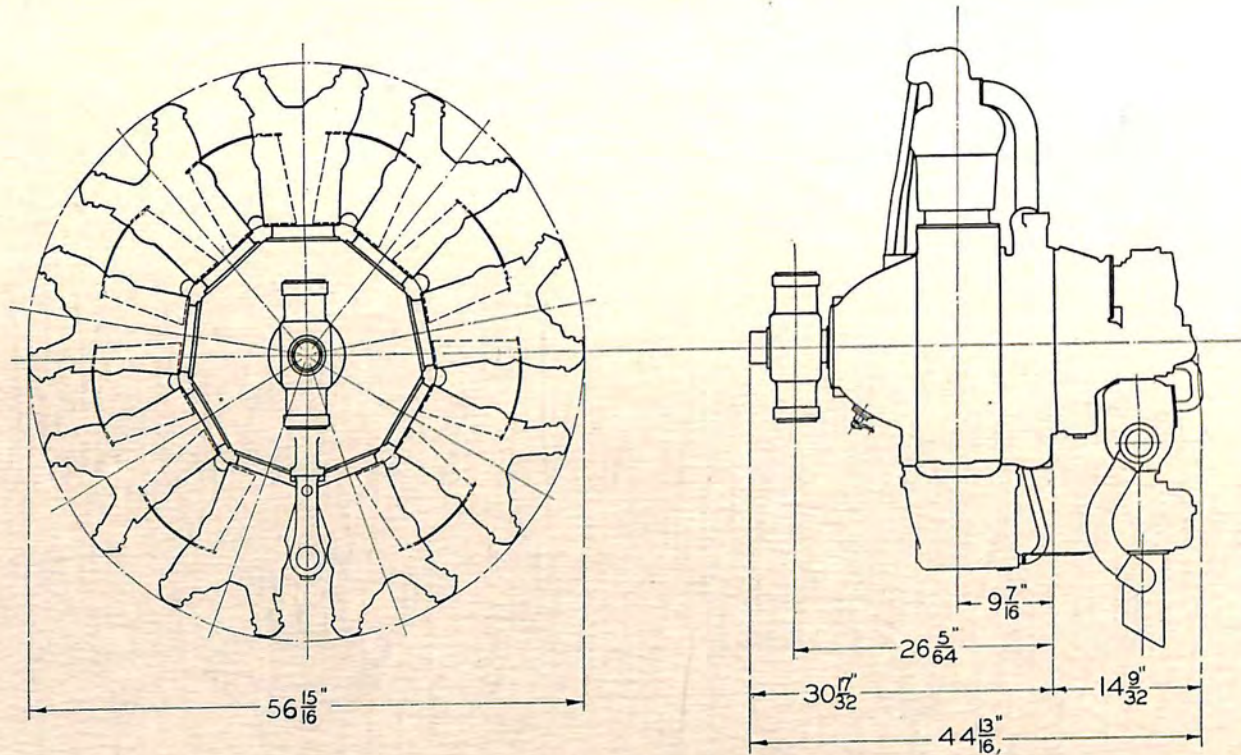

PRATT & WHITNEY AIRCRAFT COMPANY
 East Hartford, Conn.

HORNET B1 — 575-625 H.P.
 9 CYLINDER RADIAL AIRCOOLED

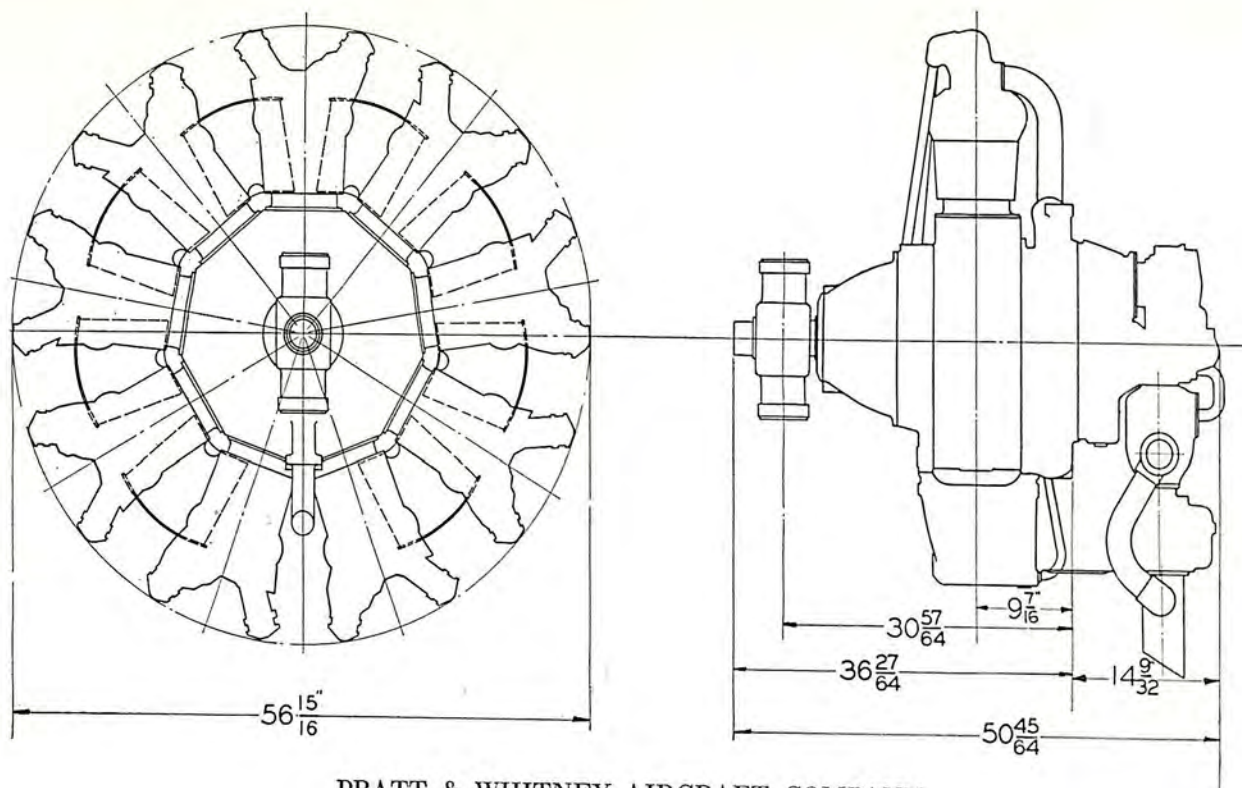

PRATT & WHITNEY AIRCRAFT COMPANY
East Hartford, Conn.

HORNET B1 (GEARED 3 : 2) — 575-600 H.P.
9 CYLINDER RADIAL AIRCOOLED

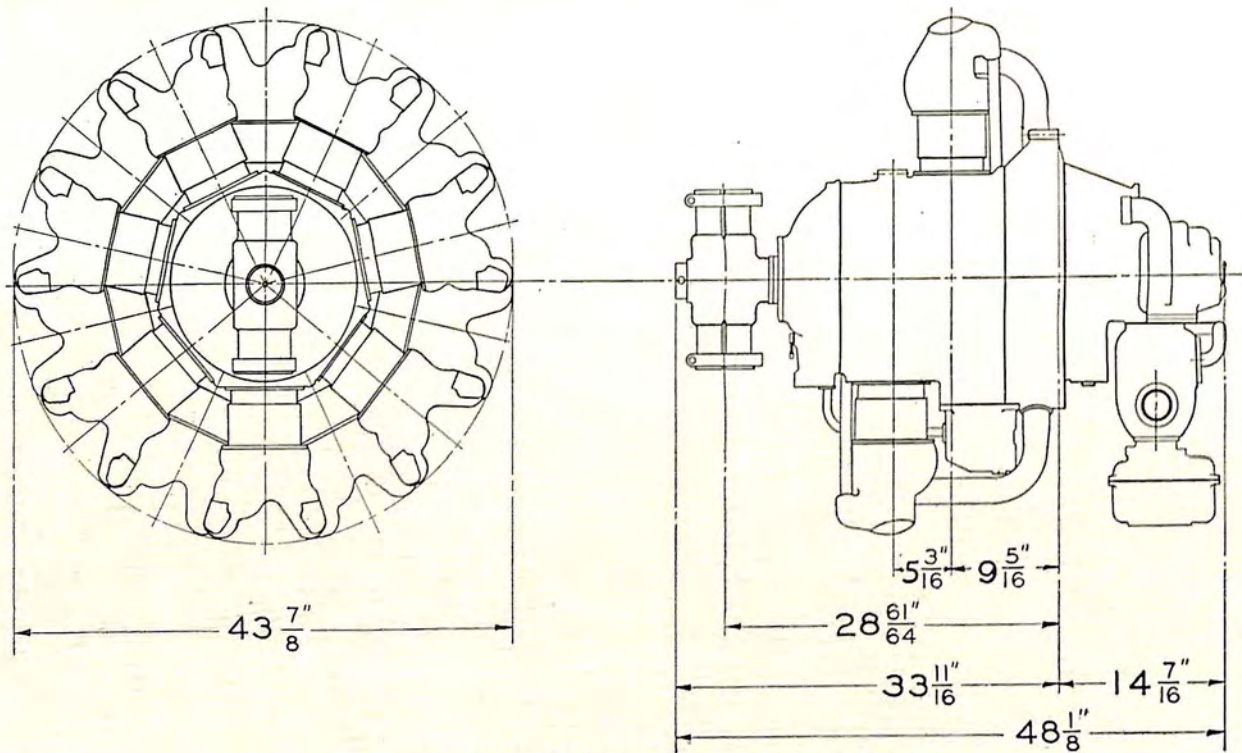

PRATT & WHITNEY AIRCRAFT COMPANY
 East Hartford, Conn.

TWIN WASP JUNIOR — 625 H.P.
 14 CYLINDER RADIAL AIRCOOLED

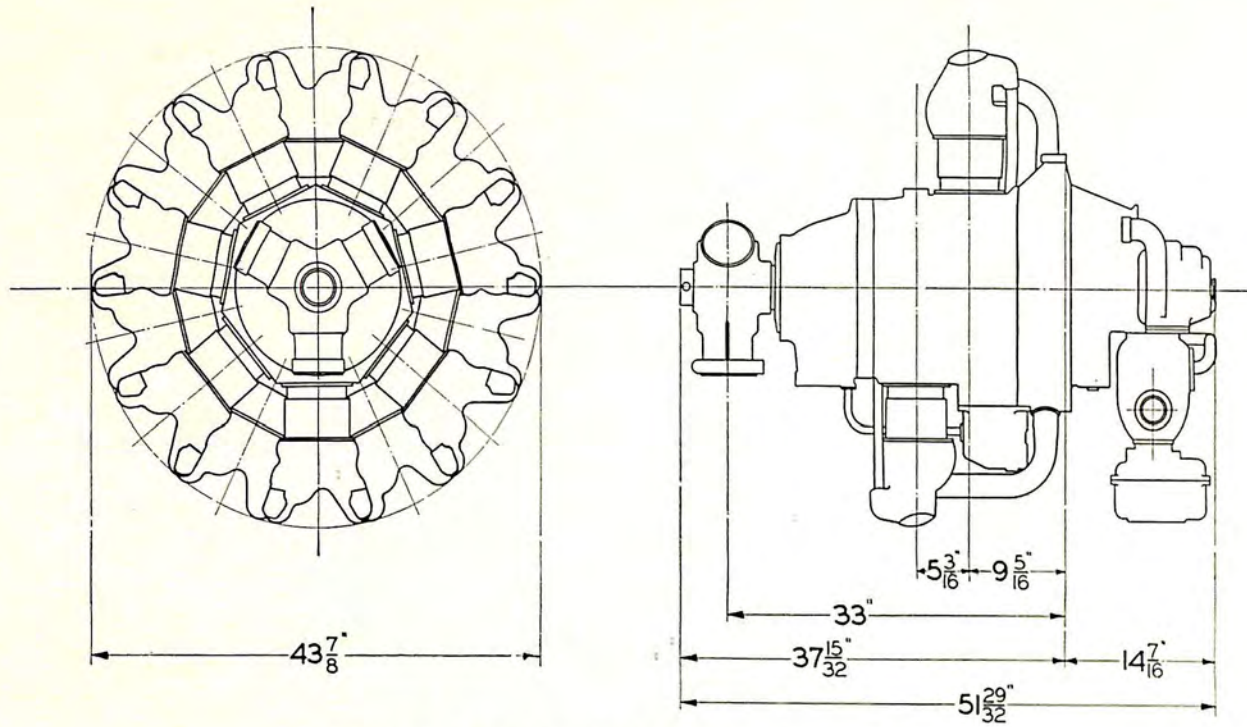

PRATT & WHITNEY AIRCRAFT COMPANY
 East Hartford, Conn.
 TWIN WASP JUNIOR (GEARED 3 : 2) — 700 H.P.
 14 CYLINDER RADIAL AIRCOOLED

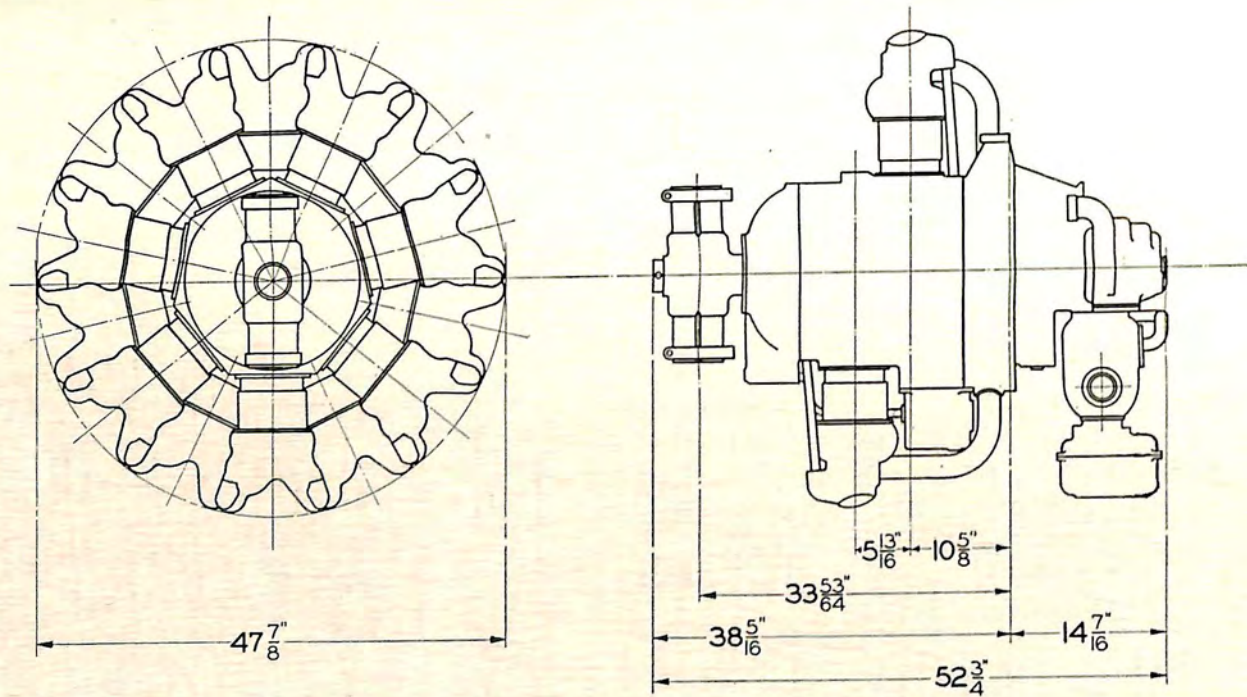

PRATT & WHITNEY AIRCRAFT COMPANY
 East Hartford, Conn.
 TWIN WASP — 675 H.P.
 14 CYLINDER RADIAL AIRCOOLED

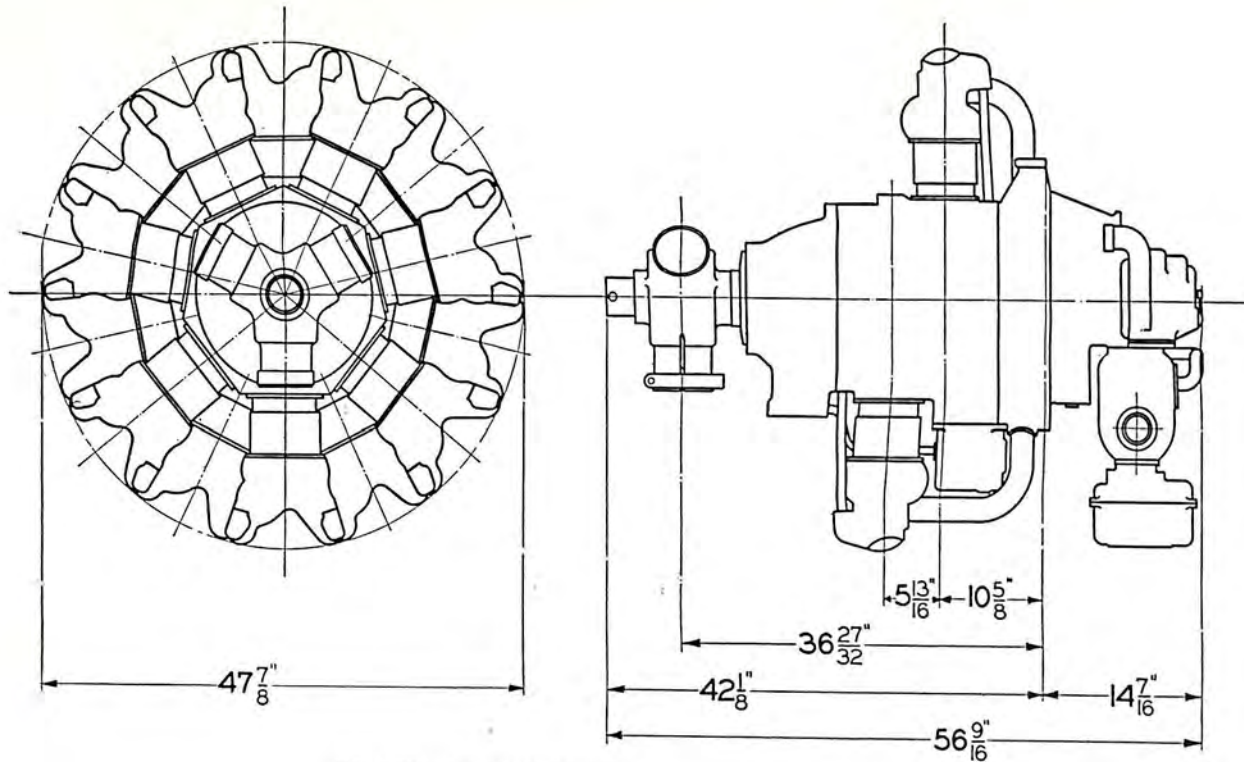

PRATT & WHITNEY AIRCRAFT COMPANY
East Hartford, Conn.

TWIN WASP (GEARED 3 : 2) — 800 H.P.
14 CYLINDER RADIAL AIRCOOLED

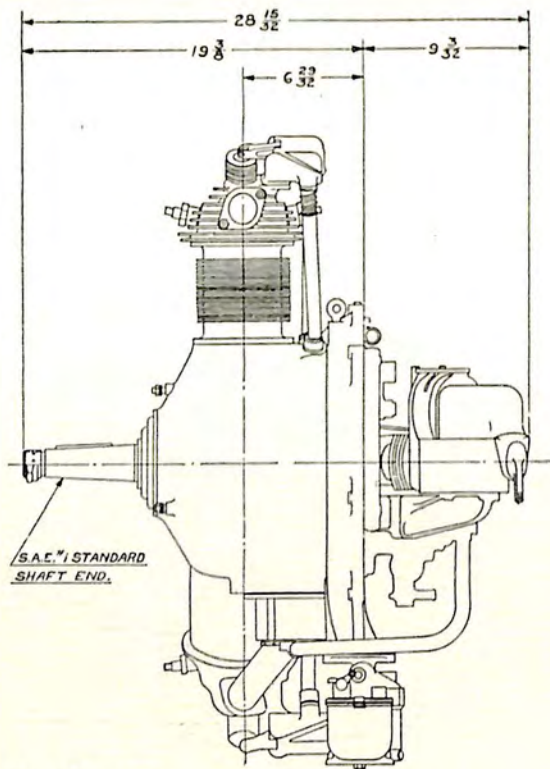
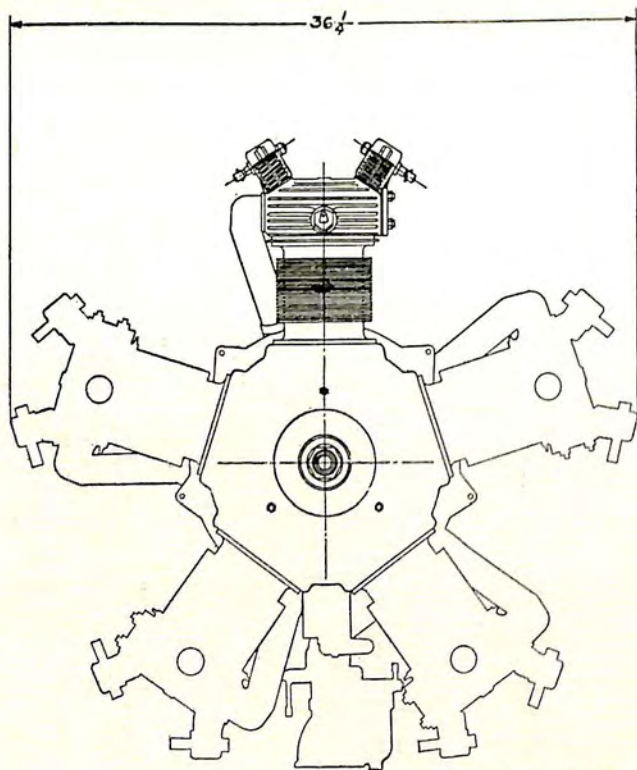

WARNER AIRCRAFT CORPORATION
 Detroit, Mich.

SCARAB, JR. — 90 H.P.
 5 CYLINDER RADIAL AIRCOOLED

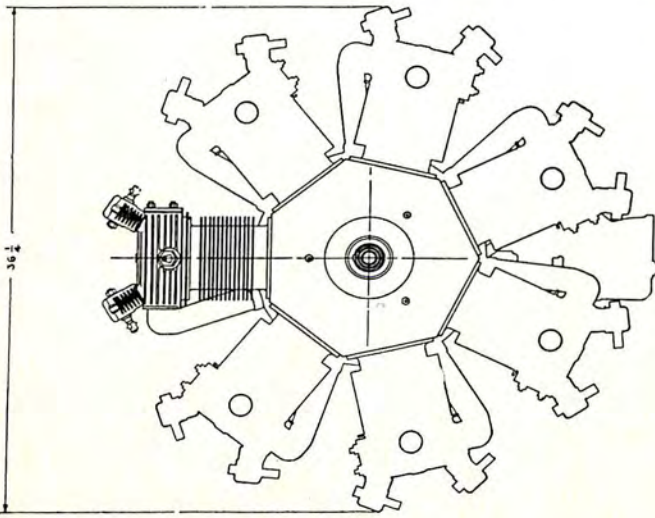
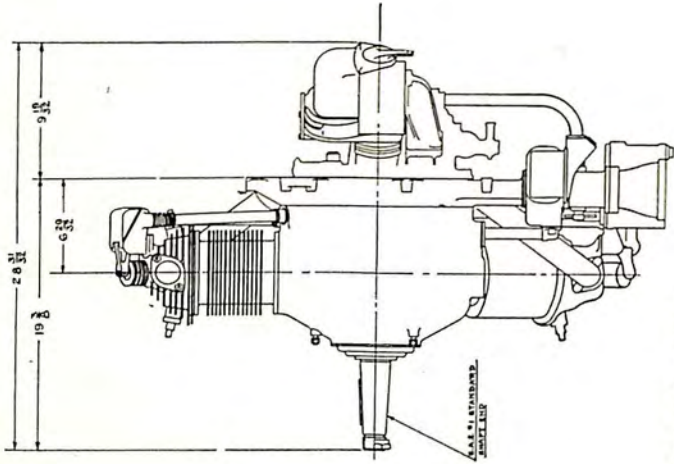

WARNER AIRCRAFT CORPORATION
Detroit, Mich.
SCARAB — 110 H.P.
7 CYLINDER RADIAL AIRCOOLED

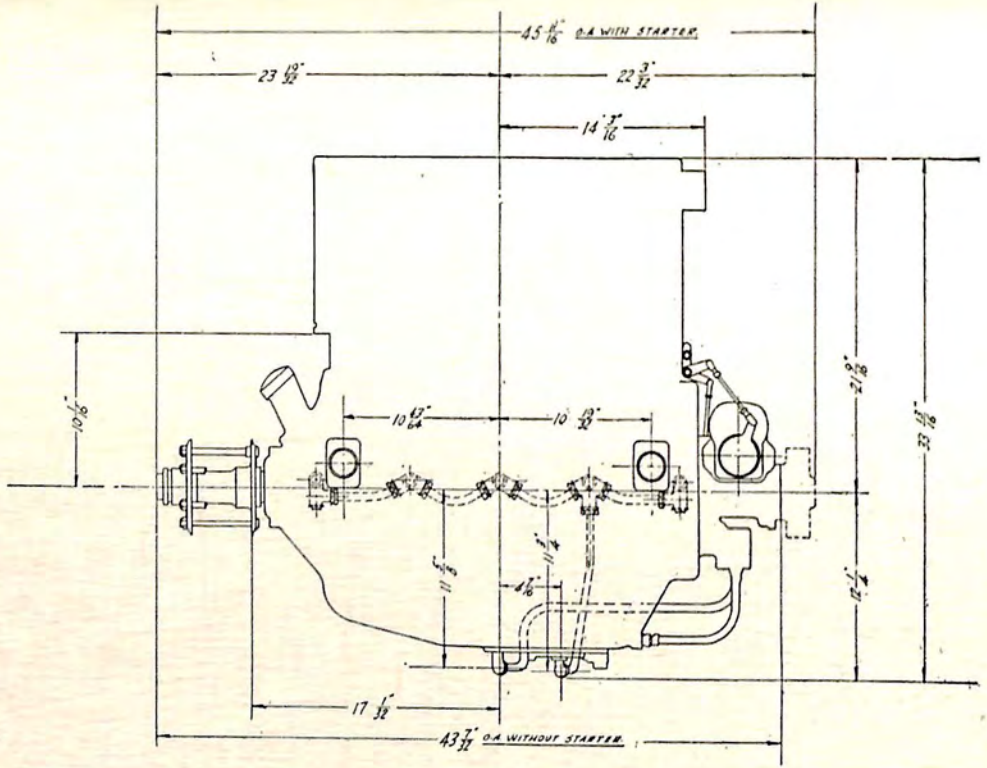
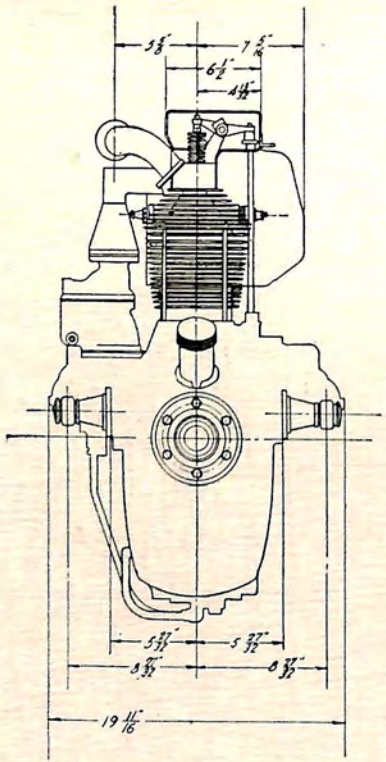

WRIGHT AERONAUTICAL CORPORATION
 Paterson, N. J.
 WRIGHT GIPSY — 90 H.P.
 4 CYLINDER IN LINE AIRCOOLED

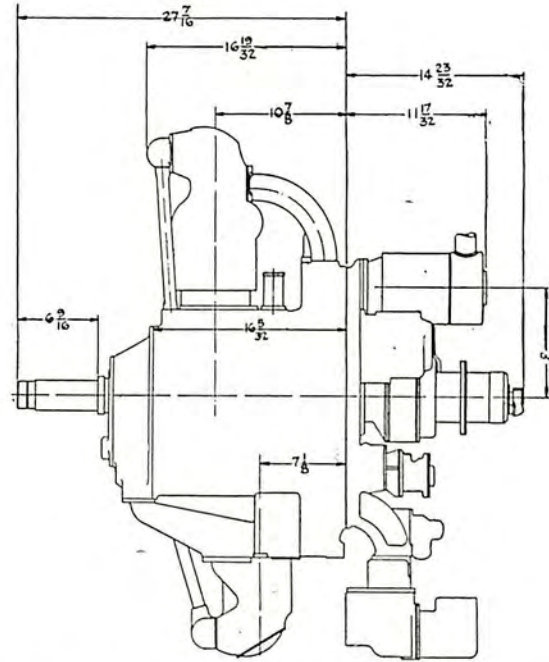
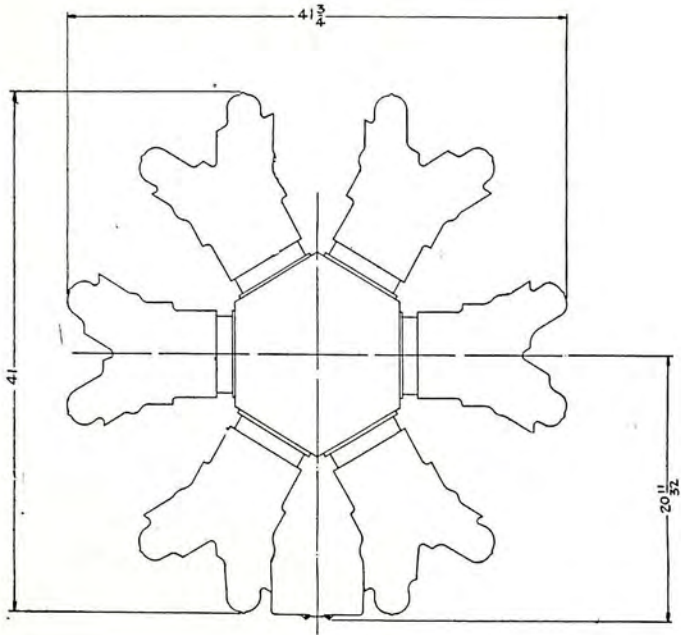

WRIGHT AERONAUTICAL CORPORATION
Paterson, N. J.

CURTISS CHALLENGER — 185 H.P.
6 CYLINDER RADIAL AIRCOOLED

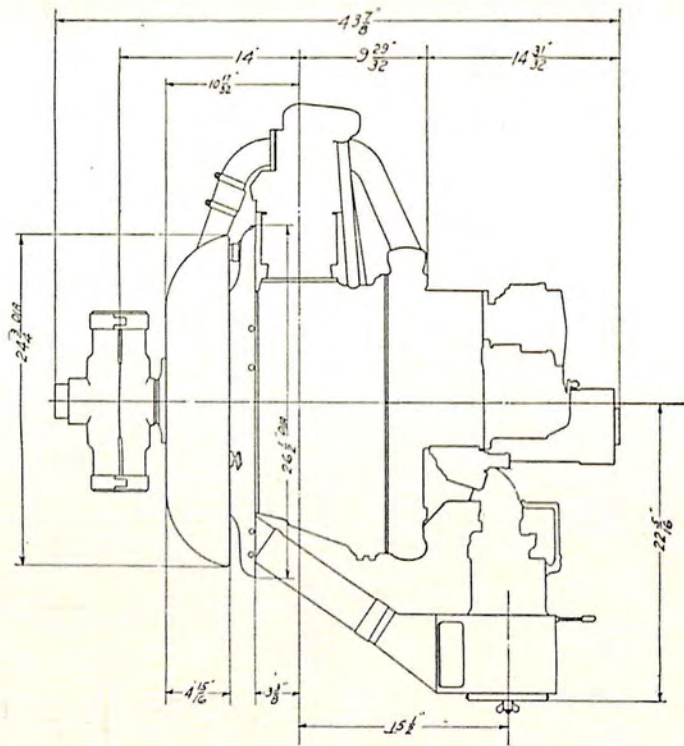
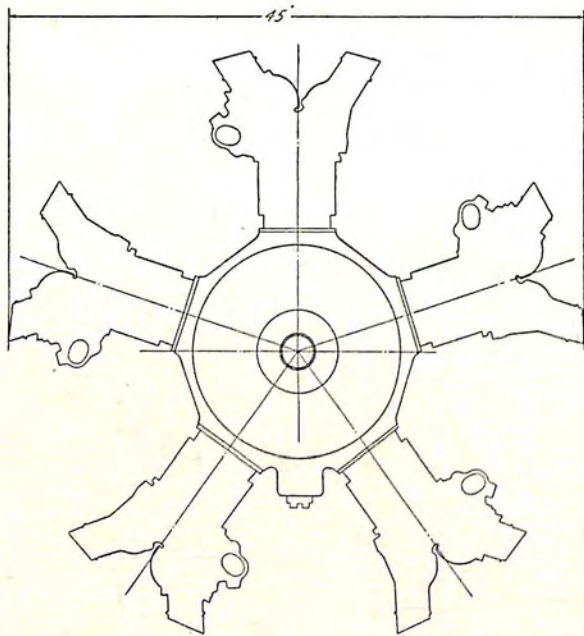

WRIGHT AERONAUTICAL CORPORATION
 Paterson, N. J.
 WHIRLWIND — 175 H.P.
 5 CYLINDER RADIAL AIRCOOLED

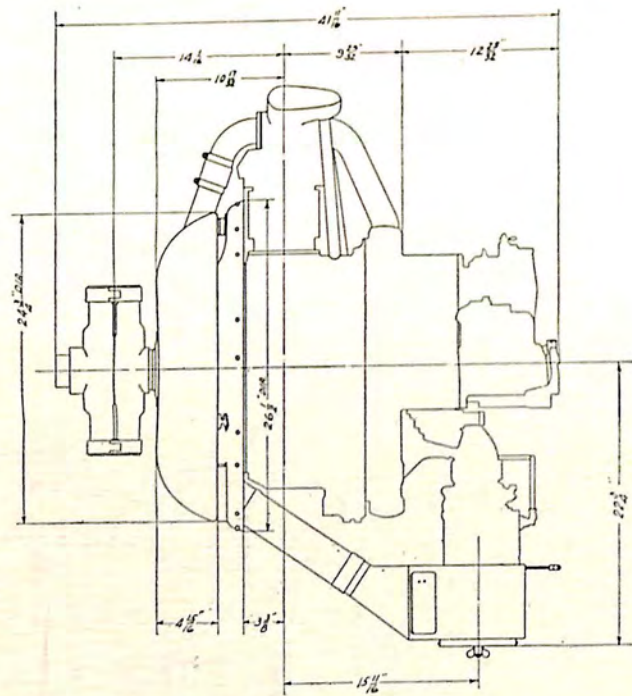
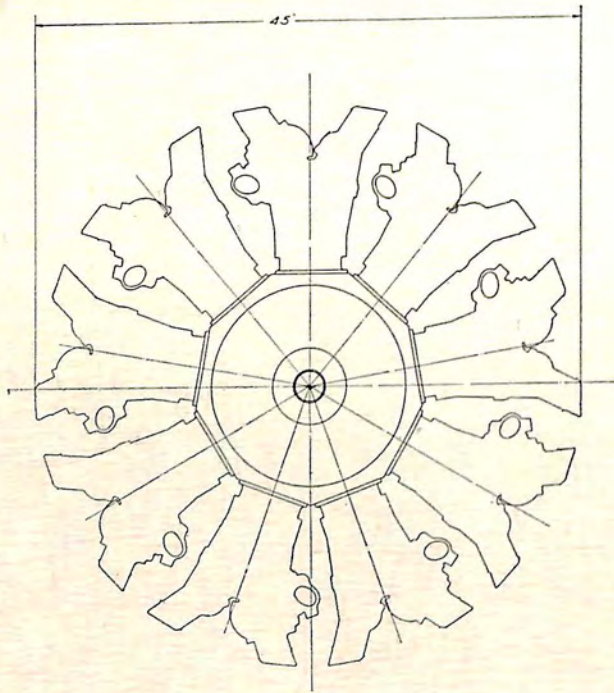

WRIGHT AERONAUTICAL CORPORATION
Paterson, N. J.

WHIRLWIND — 330, 365, and 420 H.P.
9 CYLINDER RADIAL AIRCOOLED

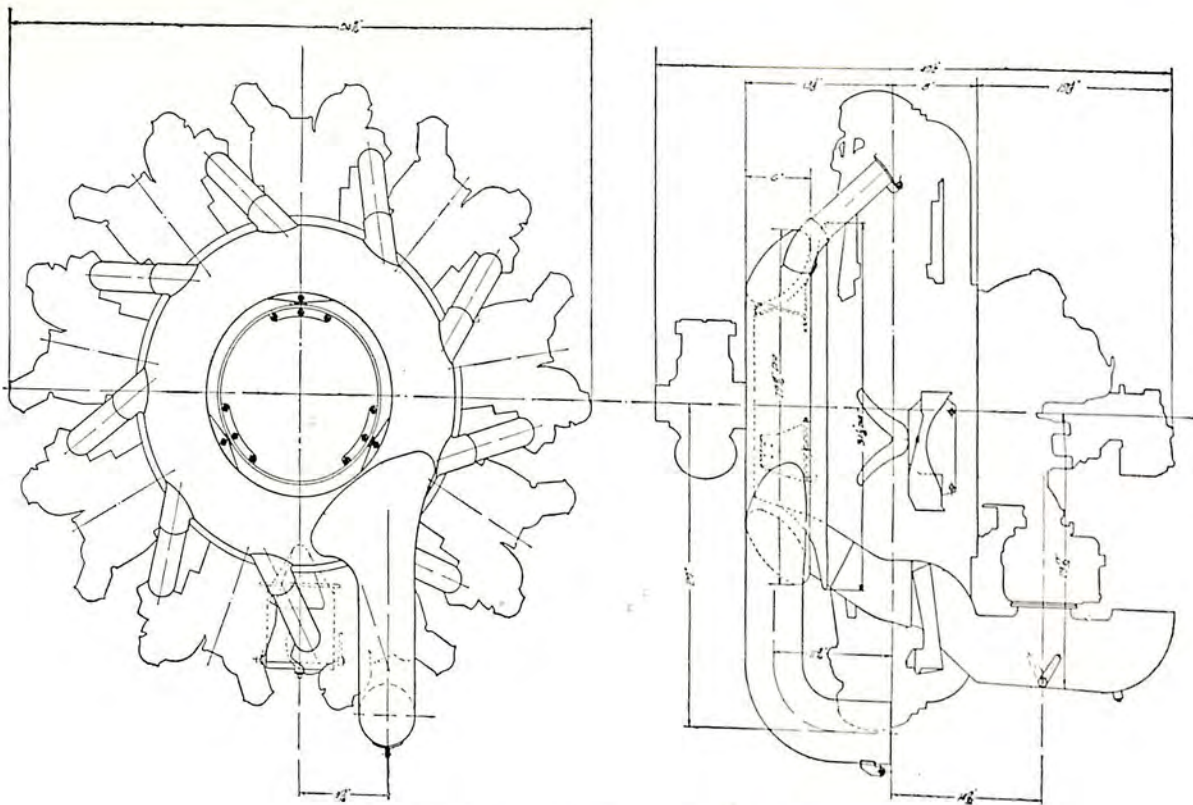

WRIGHT AERONAUTICAL CORPORATION
Paterson, N. J.

CYCLONE E — 575 H.P.
9 CYLINDER RADIAL AIRCOOLED

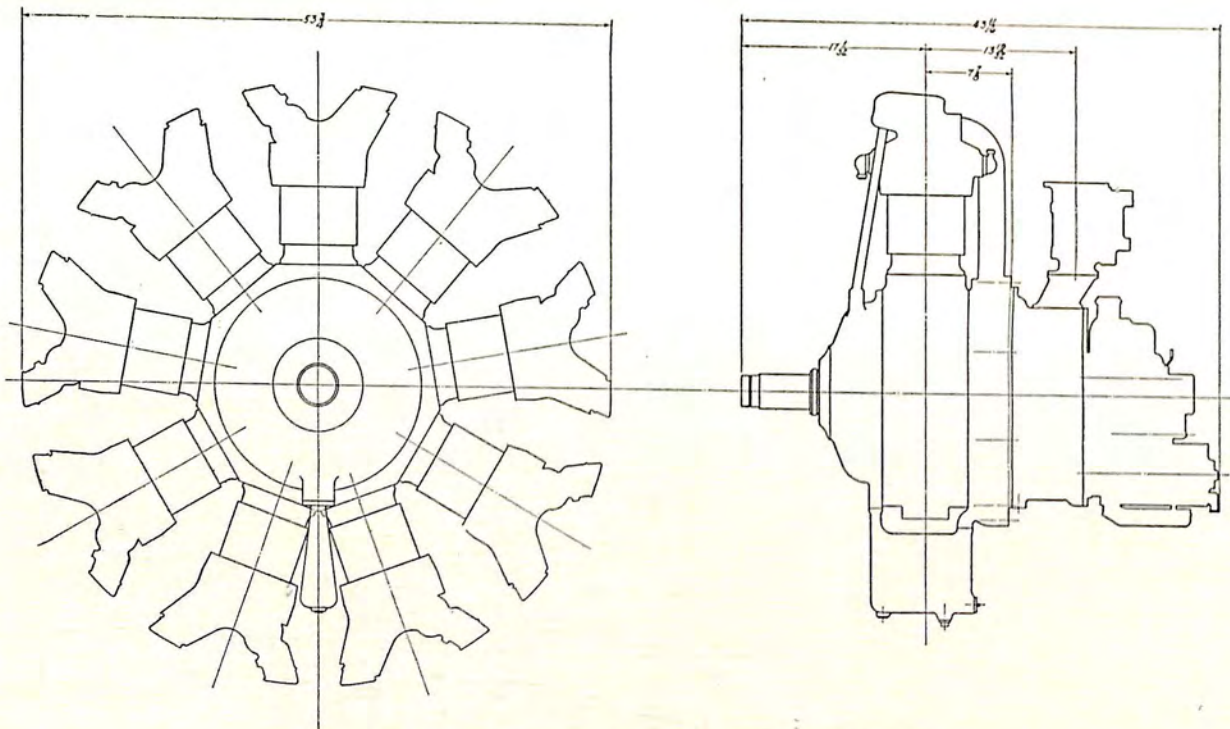

WRIGHT AERONAUTICAL CORPORATION
 Paterson, N. J.

CYCLONE F — 700 H.P.
 9 CYLINDER RADIAL AIRCOOLED

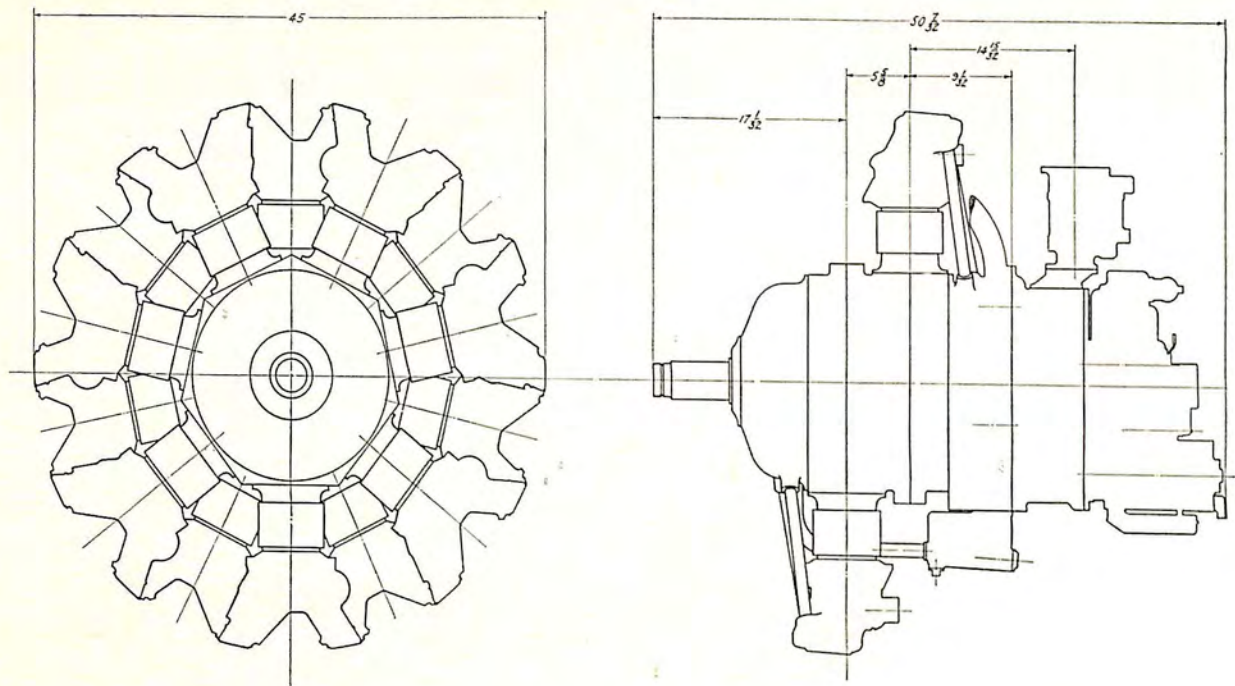

WRIGHT AERONAUTICAL CORPORATION
Paterson, N. J.

Two Row Whirlwind — 625 H.P.
14 Cylinder Radial Aircooled

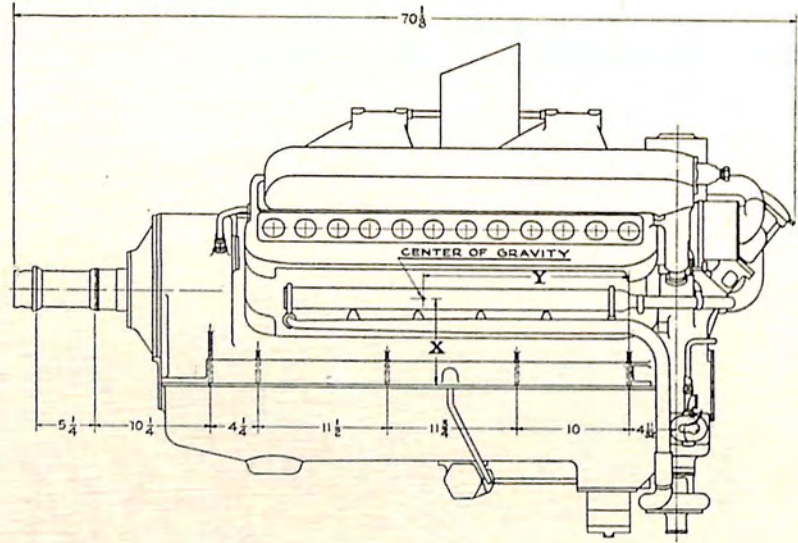
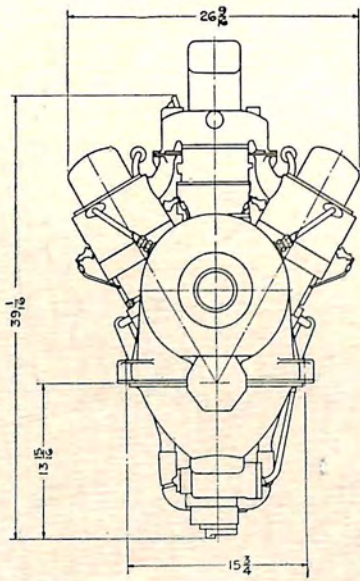

WRIGHT AERONAUTICAL CORPORATION
 Paterson, N. J.
 CURTISS CONQUEROR (GEARED) — 625 H.P.
 12 CYLINDER V TYPE LIQUIDCOOLED

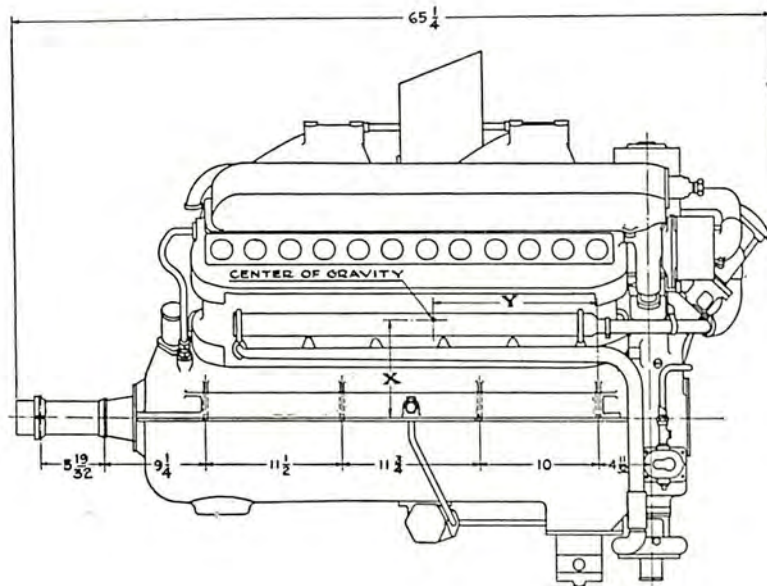
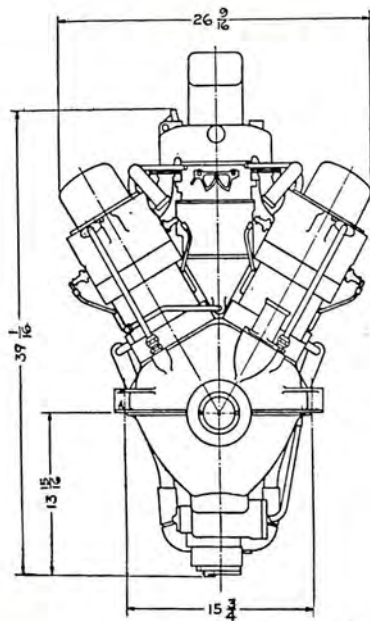

WRIGHT AERONAUTICAL CORPORATION
Paterson, N. J.

CURTISS CONQUEROR — 650 H.P.
12 CYLINDER V TYPE LIQUIDCOOLED

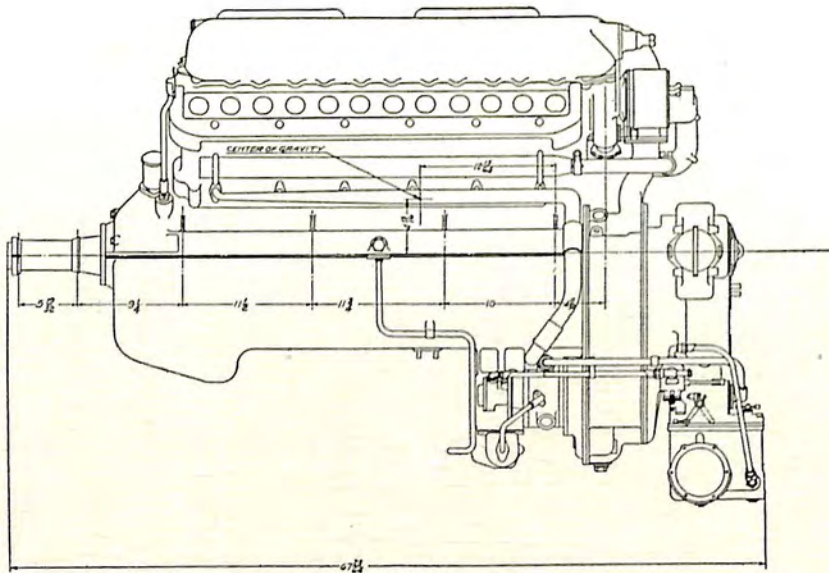
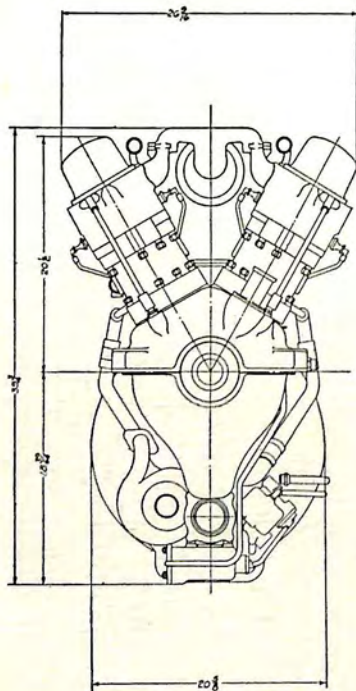

WRIGHT AERONAUTICAL CORPORATION
Paterson, N. J.

CURTISS SUPER-CONQUEROR — 600 H.P.
12 CYLINDER V TYPE LIQUIDCOOLED



PLANE-TO-GROUND COMMUNICATION

Western Air Express pilots using the new Western Electric radio receiving and sending apparatus installed during 1932.

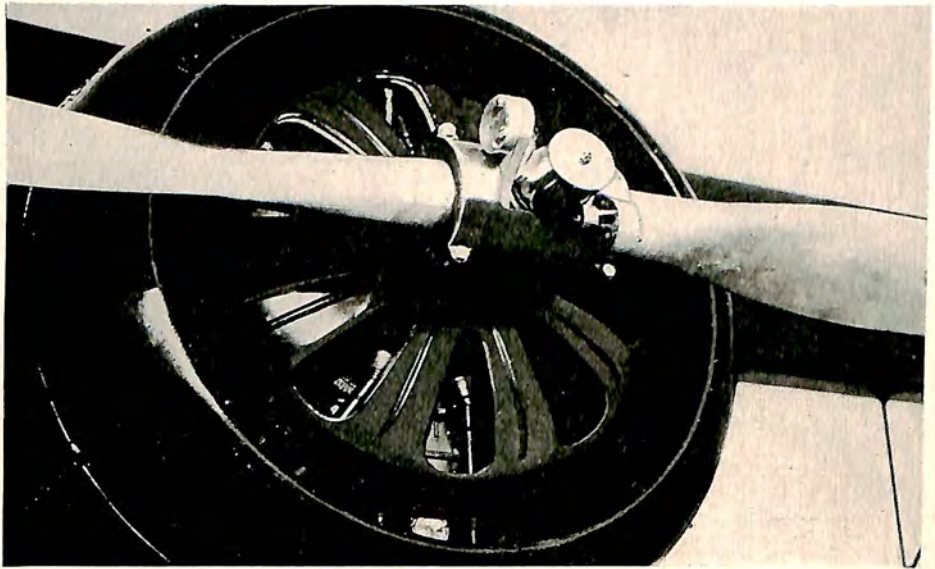

CONTROLLABLE PITCH PROPELLER

Close-up view of the new Hamilton Standard controllable pitch propeller designed to increase planes' performance.

CHAPTER XX

RESEARCH IMPROVES COMPONENT AIRCRAFT PARTS

Manufacturers of Accessories Effect Closer Liaison With Operators—Many Refinements of Electrical Units—Streamline Wheels Introduced
—Reports From Fifty Major Companies Indicate Progress

RESearch carried on by more than two score industries contributed to refinements in the design of new aircraft and engine models for 1933. Some of the most important new features of design already have been described in the two preceding chapters on "Trends in American Aircraft Design" and "Advances in American Aircraft Engines." It should be interesting to get a glimpse of the activities carried on during 1932 in 50 major factories engaged in the design and manufacture of accessories, materials and equipment which constitute component parts of the completed aircraft. A review of the new products of research in these factories should be particularly significant, because it offers a key to what may be expected in the way of new features in the design, manufacture and operation of new models. Yesterday's innovations in accessories and equipment are today's features of accepted design.

The aircraft manufacturer, responsible for the design and production of aircraft as a completed product, has learned to call on specialists in much older industries to develop wheels, brakes, instruments, tires, struts, fittings and other component parts which he needs. The engine manufacturer, likewise, would not think of designing and manufacturing his own carburetors, magnetos, starters, propellers and scores of other parts which have become standardized. Companies which supply plywood, metals, glass, rubber, leather, woods, fabrics, paints, dopes, lacquers and dozens of other necessary materials all contribute their share to the advancement of the industry through their specialized studies of aviation's needs.

The reports of 50 major companies contributing some type of component parts for aircraft, received by the Aeronautical Chamber of Commerce through its Accessory and Material Section, provide a fair picture of the year's progress in the many industries allied with aviation. The Section continued to provide an important forum for the exchange and coordination of ideas and for the carrying out of an aviation promotion program

in the interests of its diversified membership. Perhaps the most significant contribution of the Section during the year was the effecting of a closer liaison of manufacturers and operators with the producers of accessories, material and equipment. The radio and electrical equipment manufacturers represented in the Section held a joint conference with the Maintenance and Operations Committees of the Air Transport Section in May to obtain the recommendations and experiences of the operators. More than 60 companies were represented at the conference, which resulted in the setting up of machinery for a constant exchange of information between the operators and the manufacturers of radio and electrical equipment through the Chamber. To carry out this program, the Air Transport Section set up a Committee of Radio and Electrical Maintenance which included in its membership the electrical experts of all major air transport lines. Similarly, the manufacturers of tires and brakes and other units held conferences or exchanged data with the operators and aircraft manufacturers through the Chamber.

Electrical equipment manufacturers made substantial improvements in their products during 1932 affecting the performance of radio and communications, aircraft engines, propeller units for power plants, instruments and airport lighting. Such vital engine accessories as magnetos, batteries, starters, spark plugs, and radio shielding were the subject of important refinements. The Western Electric Company, Radiomarine Corporation, Aircraft Radio Corporation, S. S. White Dental Manufacturing Company and Bell Telephone Laboratories, Inc., were active in the aircraft radio and communications field. In the manufacture of electrical engine and power plant accessories, the Scintilla Magneto Company, Delco Aviation Corporation, Electric Storage Battery Company, Hurley-Townsend Corporation, B. G. Corporation, Champion Spark Plug Company, Breeze Corporation, and Eclipse Aviation Corporation made refinements in their products. The perfection of new controllable or variable pitch propellers, some of them electrically operated, by such companies as the Hamilton Standard Propeller Company, Curtiss Aeroplane and Motor Company, Smith Engineering Company, and Eclipse Aviation Corporation, offered new possibilities for increasing aircraft performance. Airport lighting units were the subject of research and development by Westinghouse Electric and Manufacturing Company, General Electric Company, Pyle National Company, Sperry Gyroscope Company and the American Gas Accumulator Company. Navigation and engine instruments were improved and new devices introduced by the Sperry Gyroscope Company, Pioneer Instrument Company, General Electric Company, Julian P. Friez and Sons, and Elgin National Watch Company.

The Western Electric Company introduced during 1932 a new type of radio telephone equipment for use in transport planes, evolved as the result

of continuous and exhaustive research combined with experience acquired through intimate contact with operating companies. Improvements in the new equipment, designed by Bell Telephone Laboratories, Inc., included a pre-selected frequency superheterodyne receiver and a new radio transmitter, both of which were arranged for rapid shifting to either the day or night frequencies. Other features were that the number of apparatus units was reduced to a minimum, wiring was completely in conduit, and an improved side tone circuit was included by means of which pilots might converse with each other. The beacon receiver could be operated separately



SPERRY INSTRUMENTS ON CONDOR

Pilot Howard Stark at the controls of Eastern Air Condor equipped with Sperry Horizon and Directional Gyro (seen at top).

from the two-way communication system, permitting one pilot to listen to the beacon while the other was listening to the ground station. Installation of radio units in new planes as a part of the manufacturers' original design represented an important step in relieving the operators of a burden as well as insuring increased efficiency of radio in aircraft. New Western Electric ground radio station units were installed by the air lines during 1932 to bring the total up to 108 in operation. Sixty-two additional transport planes were equipped with Western Electric two-way radio during the year, bringing the total up to 251 so equipped.

Aircraft Radio Corporation of Boonton, N. J., developed a dual range coil set to use with its Model D Aircraft Radio Receiver, which provided

both high and low ranges in one unit with a snap switch designed so that the pilot might choose either band at will. The new set eliminated the necessity for carrying a separate receiver and thus materially reduced the weight and space requirements as well as the cost of radio equipment. Looking ahead to the possible use of the visual radio range system, the company incorporated an automatic gain control into its new receiver and increased the power output to 500 milliwatts. The receivers were designed for government, transport and privately owned airplanes.

The Radiomarine Corporation of New York designed and marketed a very light aircraft receiver for both beacon, weather and communication services. The S. S. White Dental Manufacturing Company of New York manufactured special flexible shafting for use on remote tuning control of aircraft radio receivers and molded ear pieces for receivers designed to cut out extraneous noises. Many other articles and materials for aircraft were produced by this company as standard equipment.

The Scintilla Magneto Company, Inc., of Sidney, N. Y., a division of Bendix Aviation Corporation, brought out a series of new designs for aircraft magnetos and switches with perfected radio shielding which contributed substantially to the solution of problems of aircraft engine designers. A new product, aviation spark plugs, embodying new features of construction and performance, was developed, extensively tested under service conditions, and placed in quantity production. The close affiliation of Scintilla with Delco Aviation Corporation, another Bendix division located in Sidney, enabled these two organizations to offer the aircraft industry every type of ignition equipment, both magneto and battery types.

The Electric Storage Battery Company worked closely with the air transport operators and manufacturers through their Chamber committees on the design of a new type battery which combined ability to meet heavy discharges at high rates, with minimum loss in voltage, minimum weight and space, and a high degree of dependability. The result of research during the year was the offering of a new type battery incorporating the so-called "non-slop" feature instead of the "non-spill" type required for acrobatics and military planes. The new battery, especially designed for air line operation where planes are never put through violent maneuvers, combined low weight with ability to meet heavy discharges.

Spark plugs which combined several new features to insure greater dependability and longer life were developed during the year by the Hurley-Townsend Corporation and B. G. Corporation. Both companies offered plugs which were radio shielded to eliminate interference with aircraft radio. The Breeze Corporations of Newark, N. J., manufacturers of complete radio shielding harnesses for aircraft engines, introduced a new line of flexible aluminum conduits and fittings for all light and power lines on aircraft. This new shielding not only eliminated interference from

ignition and power lines with clear radio reception, but reduced the fire hazard due to broken wires or short circuits.

The Eclipse Aviation Corporation of East Orange, N. J., a division of Bendix Aviation Corporation, continued its manufacture of starters and generators and added seven other aeronautical devices to its line: automatic variable pitch propeller hubs, ice overshoe pumps, instrument vacuum pumps, engine superchargers, fuel flowmeters, automatic supercharger regulators, and flexible metallic tubing. Developed in collaboration with the B. F. Goodrich Rubber Company, the ice overshoe device consisted of a



NEW "ABRASION SHOES"

Maj. James H. Doolittle examines the new Goodrich abrasion shoes on his Lockheed Shell Oil Executive plane.

corrugated sheet rubber covering applied to the leading edge of the wing and other surfaces, which was inflated pulsatively by a pump controlled by a valve manually operated by the pilot. The ice was cracked and thrown from the wing and control surfaces by inflation of the ice overshoe. The automatic variable pitch propeller hub, one of the most interesting products of the company's recent research, permitted automatically selected adjustments of the propeller blade pitch and offered advantages of controllable pitch propellers, such as a reduction in the distance required for take-offs and landings, as well as an increase in the engine horsepower and speed of the plane. The instrument vacuum pump, produced to replace the venturi, operated suction driven navigation instruments such as the arti-

ficial horizon, gyroscopic compass, and turn and bank indicator and eliminated the possibility of iced venturis in cold weather.

Sky Specialties Corporation of Detroit, Mich., developed a new Heywood starter operated from the cockpit or instrument board by pulling or pushing a button. It was adopted on many new model planes. The company also manufactured rubber-covered aluminum and copper tubing which guarded against broken gas or oil lines.

Many designers watched with keen interest the development of controllable pitch propellers, which offered increased performance for aircraft through decreasing the distance for landings and take-offs and increasing the speed of the plane. Several propellers of this type under development reached new stages of improvement during the year. The Curtiss Aeroplane and Motor Company of Buffalo, N. Y., carried out flight tests of its automatic electric controllable pitch propeller, with marked results. The Smith Engineering Company of Cleveland, O., utilized the motive power supplied by the rotation of the hub around a special control worm, mounted in the thrust bearing cover plate, to actuate the change of pitch of its propeller's blades in flight. Operation of the Smith propeller was controlled by the pilot from the cockpit. The Gee Bee Super-Sportster, flown by Maj. James H. Doolittle to a new world record for land planes of 294 miles an hour, was equipped with one of these propellers. The Hamilton Standard Propeller Company, major manufacturers of adjustable pitch propellers, also offered a new controllable pitch propeller as an addition to its line in 1932. The Hamilton Standard controllable pitch propeller was manufactured for engines ranging from 90 to 625 horsepower and each type had completed several hundred hours of successful flight tests. Its controllable mechanism utilized a hydraulic principle making use of the engine oil pressure in combination with centrifugal forces. The cockpit control was simple, consisting only of a level to operate the three-way oil valve.

New airport lighting equipment introduced by the Westinghouse Electric and Manufacturing Company of East Pittsburgh, Pa., included: a portable traffic signal, an airport traffic signal, Fresnel type landing field floodlights, signalling searchlight, control desk and a photolux control relay. The traffic signal was a gun-like device with two pistol grip handles, which controlled red, green and yellow color filters used in sending dot-dash signals to planes in the air 10 to 15 miles away. The signalling searchlight was for airships, blimps and captive balloons. The photolux light control relay automatically switched airport and airway lights and beacons on or off in accordance with the density of light. It was designed for use on remote beacon sites, and was more accurate than astronomical clocks in use for such purposes. The control desk centralized all switches for lights on the airport. The new landing field floodlight was designed for

use where a pancake shaped beam of medium candlepower was desired, especially for irregularly shaped fields.

American Gas Accumulator Company of Elizabeth, N. J., handling the sales of airport lighting equipment developed by the Sperry Gyroscope Company, offered a high intensity arc floodlight with a 1,000 mm. Dioptric lens. The lens was supplied by AGA. The floodlight provided a 2,000,000 candlepower beam and had as an added safety feature an automatic lamp changer which swings a 1,000,000 candlepower lamp into position if the other lamps fail. Airport beacons, also manufactured by the Sperry Com-

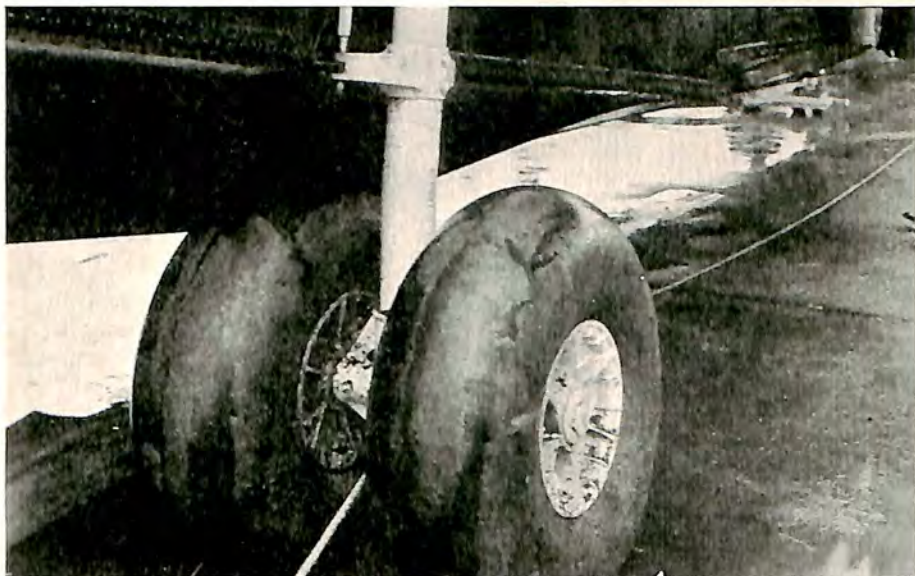

BENDIX BEACHING GEAR

Specially designed Bendix beaching gear for Consolidated flying boat as seen from the ship's port side.

pany, were sold by American Gas Accumulator. The General Electric Company of Schenectady, N. Y., carried on research and made some refinements in its line of lighting equipment and aviation instruments.

With the new Department of Commerce requirements for instrument flying in effect January 1, 1933, the importance of navigation instruments as an essential part of transport aircraft became more pronounced. While most of the lines had trained their pilots in instrument flying and provided them with the principal navigation instruments, the new regulations made a knowledge of instrument flying by air line pilots mandatory.

Three instruments, produced and developed by the Sperry Gyroscope Company, which were finding increased use on air line transports were

known as the Sperry Horizon, a gyroscopic flight instrument simulating the natural horizon and indicating the degree of bank, climb and dive; the Directional Gyro, a gyroscopic instrument providing a stabilized compass card which would not oscillate on changing course or in rough air; and the Airplane Gyro-Pilot, an electro-mechanical-gyroscopic unit to control the rudder, ailerons and elevator and automatically pilot the airplane. The latter was designed to relieve the pilot on long flights. Features added to the Sperry Horizon in 1932 included: decreased size and weight of the rotor case element, added banking indicator, changed design of the face to obtain greater clearness, and increased quality of the bearings for longer life. The trend in design was toward lighter and more rugged products.

The Pioneer Instrument Company of Brooklyn, N. Y., a division of Bendix Aviation Corporation, continued the manufacture of its three compass types—Mark VII, B-9, and D-4—used on production aircraft. The Pioneer electric Pitot tube was designed to make it possible to renew quickly the electric elements in electrically heated Pitot tubes. To aid manufacturers in making accurate tests for acceleration, the Pioneer company introduced an accelerometer which indicates the degree of acceleration and continues to indicate the maximum reached until reset. The increasing use of supercharged engines prompted the development of a supercharger gauge indicating in inches of mercury the pressure existing in the supercharged intake manifold. The company also introduced an electric tachometer, after many months of research, having no brushes or moving parts of any kind. Its range was from 500 to 3,000 r.p.m. Julian P. Friez and Sons, another division of Bendix Aviation Corporation, continued its development of special weather instruments for airports.

The landing of aircraft on land or water presents problems for the aircraft designer in the building of a suitable structure with wheels or floats, equipped to withstand the impact in landing. To the solution of this problem, which became further complicated with the introduction of higher speeds and heavier loads, the manufacturers of wheels, brakes, tires, floats, pontoons, and struts—all of them components manufactured by specialists—contributed materially.

The Bendix Brake Company of South Bend, Ind., another division of Bendix Aviation Corporation, developed during 1932 a complete new series of wheels, especially designed in conjunction with tires of special shape to have a minimum of parasite resistance. They were called "Streamline Wheels." Together with new design brakes, they represented the contribution of Bendix to improved undercarriage design. As the result of three years of quiet study, the company introduced for service tests on military and commercial airplanes a "Pneudraulic Strut," a direct oleo shock dissipating device, utilizing compressed air for taxiing purposes.

The development of a light, simple foot pump contributed to the success of the strut. In collaboration with the B. F. Goodrich Rubber Company, Bendix Brake Company developed a beaching gear wheel for the new giant Consolidated patrol flying boats, designed to carry a maximum load of 5,000 pounds. Goodrich developed tires for these wheels capable of standing such a load. The company reported a well defined trend toward retractable landing gears or extremely low parasite gears of the fixed type, with low pressure wheels and tires of either the conventional or streamline type for all planes.

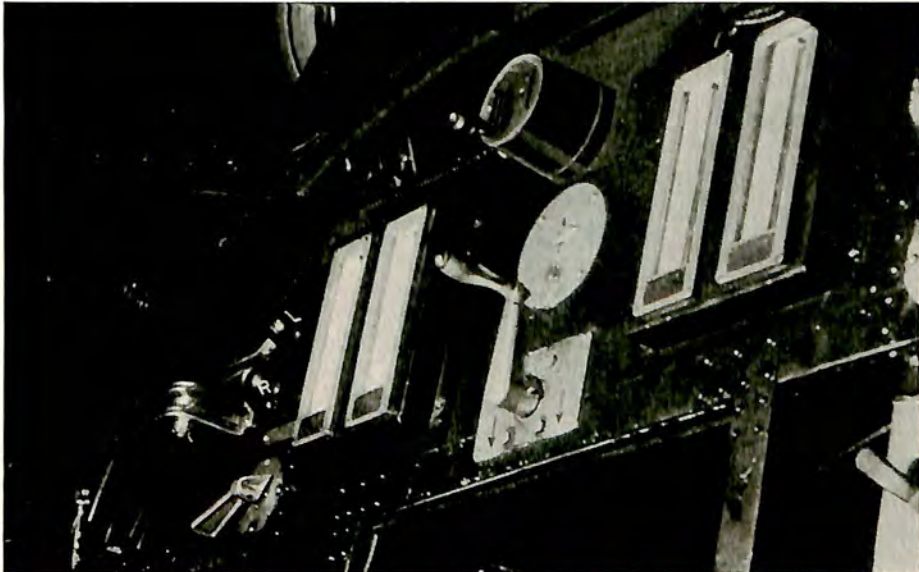

RADIO FREQUENCY SHIFT

Frequency shift (top of instrument board) for both transmitter and receiver in new Western Electric radiophone system.

The Cleveland Pneumatic Tool Company of Cleveland, O., for years an important contributor to the design of adequate undercarriages for aircraft, continued the production of Aerol Struts. Pneumatic struts were constructed in all styles and sizes to meet the needs of planes varying from small sports ships to giant transports.

In addition to the research which it carried on in conjunction with Eclipse Aviation Corporation on the development of de-icers and with the Bendix Brake Company of giant tires for a new beaching gear, the B. F. Goodrich Rubber Company of Akron, O., continued production of its Silvertown line of low and high pressure tires and tubes, rubber floor matting, refueling hose, shock absorber cord and other rubber products

used in aircraft. One of its interesting new developments was an "Abrasion Shoe," a fabricated rubber strip applied to the leading edges of wings, rudder and stabilizers to prevent abrasion of these surfaces by sand and stones upon landing or by rain and sleet in flight. There was a decided trend toward higher pressures in low pressure tires noted by the company during 1932.

The Goodyear Tire and Rubber Company of Akron, O., also reported widespread acceptance of its line of low pressure Airwheels and Airwheel brakes, designed to reduce maintenance costs due to their ability to permit take-offs from rough and soft fields. High pressure wheel equipment was expected by executives of this company soon to be a thing of the past.

Edo Aircraft Company of College Point, L. I., obtained several new Approved Type Certificates on its pontoons and supplied units to the Alaskan Division of Pan American Airways and Island Airways of Cape Cod. Its new style float with automatic water rudders gained wider acceptance among seaplane pilots. The rudder floats were fully described in "The Aircraft Year Book for 1932."

The increased use of metal in new aircraft designs brought to the fore the work of those companies specializing in this field. The Aluminum Company of America developed and placed on the market during 1932 a new alloy, known as 24S, which had mechanical properties appreciably higher than those of 17S, more commonly known as duralumin. This new alloy also was available in Alclad forms. Use of the new alloy permitted further savings in weight without loss of strength. The company also introduced a new alloy known as A-355 for use in cylinder heads required to withstand higher operating temperatures than those permitted with the alloy 355. Forged pistons also were made available in alloy 18S in addition to those in 32S. The use of aluminum tubing for oil and fuel lines showed a marked increase.

The Summerill Tubing Company of Bridgeport, Pa., in addition to producing aircraft tubing of higher specifications than ever before required, manufactured for special demands tapered tubes and tubes with reinforced ends. Progress made in connection with this research project indicated that regular production of tapered tubes for the industry would be undertaken soon.

The Macwhyte Company of Kenosha, Wis., manufacturers of streamline and internal tie rods, developed in collaboration with the War and Navy Departments stainless steel tie rods, which had greater corrosion resisting qualities and were able to withstand fatigue better. John A. Roebbling's Sons Company of Trenton, N. J., concentrated its production on aircraft control cords, insulated wires for power and lighting, control casing, and cable for towing aircraft targets.

Haskelite Manufacturing Corporation of Chicago, Ill., and Grand

Rapids, Mich., manufacturers of aircraft Plywood and Plymetl, reported some new developments in panels for cabin ships, including specially constructed floor panels with a core of Balsa wood reinforced with latticed strips of spruce, cabin lining panels treated for fire-resistance and Phemaloid faced lining panels. The company reported increased sales in all-spruce Plywood. The Thurston Cutting Corporation of New York City continued to supply the industry with its Grade A airplane fabric, balloon cloth and many styles of tapes, and added to its line pre-doped surface tape, special fabric for pneumatic life rafts and a fabric for pilots' jackets. The Wellington Sears Company of New York also continued its line of fabrics for airplanes and gliders.

Berry Brothers of Detroit, Mich., major manufacturers of dopes, lacquers and paints for aircraft use, made improvements during 1932 in quick drying aircraft enamels, particularly for flying boat work and for finishing plywood covering on airplanes. Further progress was reported in the finishing of aircraft fabric in the high gloss, pigmented dope system, giving a finish on fabric similar to that on automobiles.

Metallurgical Laboratories, Inc., of Philadelphia, Pa., specialized in the manufacture and heat treatment of metal parts of high strength such as the landing gear, steel wing beams, struts, fittings and similar components. Vertical heat treating furnaces, the largest in the world, were employed to handle work two feet in diameter and 25 feet long. Steel wing beam construction in Curtiss-Wright, Stinson and Bellanca planes was made possible through the heat treating facilities of this organization.

Air Reduction Sales Company of New York introduced the use of liquid air in shrinking and fitting bushings into cylinder heads, a new use for this product. SKF Industries, Inc., of New York made no outstanding changes in its products but supplied bearings to all branches of the industry. Thompson Products, Inc., of Cleveland, O., continued improvement of its line of valves and engine parts. The Dow Chemical Company of Midland, Mich., and the Pittsburgh Screw and Bolt Company of Pittsburgh both were active in their respective fields.

The Imperial Brass Manufacturing Company of Chicago, Ill., manufacturers of fuel line fittings, primers, welding equipment, service tools, aircraft sanitary equipment, and paint spray apparatus, developed and produced the sanitary equipment for the two giant naval airships, "U.S.S.Akron" and "U.S.S.Macon." The Vellumoid Company of Worcester, Mass., continued to be a major supplier of sheet packing and gaskets to the manufacturers of aircraft engines.

The Security Sportswear Company of Chicago, Ill., cooperated with the Army Air Corps in the design and development of a two-piece winter flying suit to add to its line of suits, helmets, gloves, jackets and coveralls for aviation use. The International Flare and Signal Company of Tippe-

canoe, O., continued the development and production of its landing flares to aid in making night landings or to be fired as signals from the ground to planes in flight. The American La France and Foamite Corporation of Elmira, N. Y., produced a complete line of fire fighting equipment especially adapted for use at airports. The Irving Air Chute Company of Buffalo, N. Y., and Switlik Parachute and Equipment Company of Trenton, N. J., continued to be the major producers and developers of parachutes, both companies having perfected compact types built in as a part of aircraft chairs.

PART III

Aviation Chronology and Records

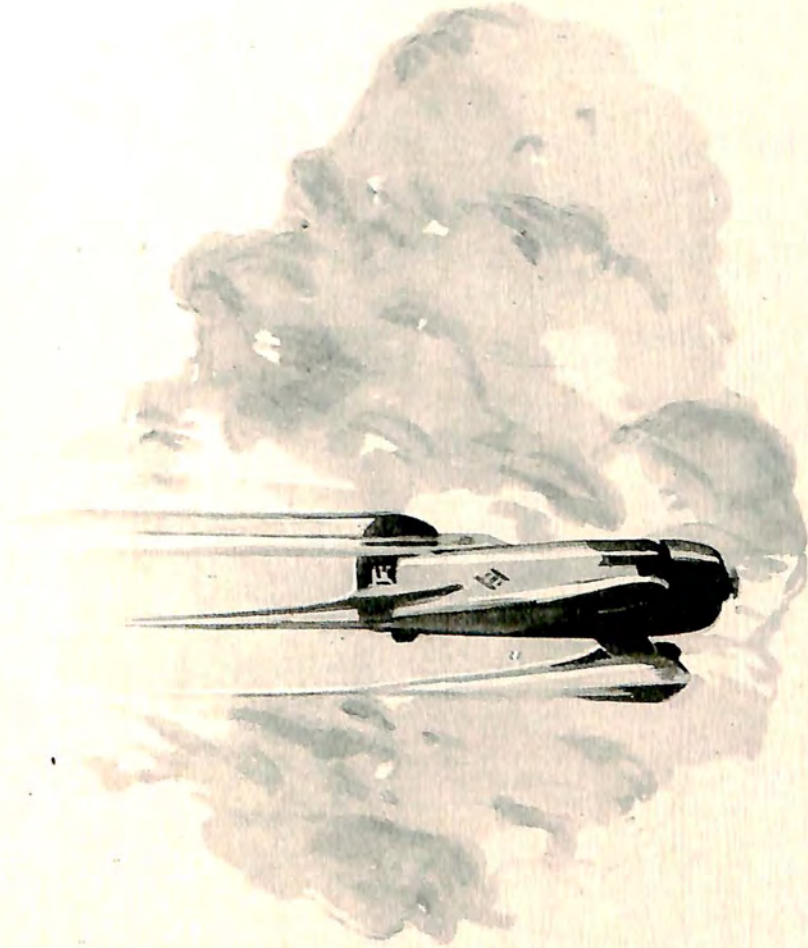

SUBJECT	PAGE
Chronology for 1932	381
Official World and American Air Records	384
National Balloon Race Results	398
International Balloon Race Results	399
National Air Races for 1932 Results	400

CHRONOLOGY FOR 1932

- Jan. 7-10 Fourth Annual All-American Air Races held at Miami, Fla.
- Jan. 16 Grand Gold Medal of the Fédération Aéronautique Internationale is awarded to Dr. Hugo Eckener for his achievements in aeronautics.
- Jan. 16 United Air Lines inaugurates air mail service between Omaha, Nebr., and Watertown, S. D.
- Jan. 20 Imperial Airways extends air mail service to Cape Town, South Africa.
- Jan. 21-24 Paul Codos and Henri Robida fly from Hanoi, French Indo-China, to Paris, France, in 3 days, 4 hrs. 17 min. (Breguet 33, Hispano-Suiza motored.)
- Jan. 23 Capt. Frank M. Hawks flies from Agua Caliente, Mexico, to Vancouver, B. C., and return in 13 hrs. 44 min. (Curtiss-Wright Travel Air, Wright Whirlwind motored.)
- Jan. 24 Clarence Chamberlin establishes altitude record for Diesel-powered planes of 19,393 ft. (Lockheed Vega, Packard-Diesel motored.)
- Jan. 30 Monument to Wilbur Wright dedicated at site of first aviation school at Pau, France.
- Feb. 14 Ruth Nichols establishes altitude record for Diesel-powered planes of 19,928 ft. at Floyd Bennett Field, Brooklyn, N. Y. (Lockheed Vega, Packard-Diesel motored.)
- Feb. 26 L. S. Thompson Speed Trophy presented to Lieut. G. H. Stainforth for establishment of record of 406.997 m.p.h. on Sept. 29, 1931.
- Mar. 21-29 "Graf Zeppelin" flies from Friedrichshafen, Germany, to Pernambuco, Brazil, and return.
- Mar. 23-26 Lucien Bossoutrot and Maurice Rossi establish closed circuit distance record of 6,575 miles at Oran, Algeria, in 76 hrs. 35 min. (Bleriot-Zappata 110, Hispano-Suiza motored.)
- Mar. 24-28 Capt. James A. Mollison flies from Lympne, England, to Cape Town, South Africa, in 4 days, 17 hrs. 19 min., establishing new record. (DeHavilland Puss Moth, De Havilland Gipsy III motored.)
- Mar. 31 Collier Trophy awarded to Packard Motor Car Company for development of the Diesel aircraft engine.
- Apr. 2-10 National Aircraft Show held at Detroit, Mich., under auspices of Aeronautical Chamber of Commerce.
- Apr. 5-13 "Graf Zeppelin" flies from Friedrichshafen, Germany, to Pernambuco, Brazil, and return.
- Apr. 17-20 Marcel Goulette and Jean Salel fly from Paris, France, to Cape Town, South Africa, in 3 days, 18 hrs. 15 min. (Farman 190, Lorraine motored.)
- Apr. 18-27 "Graf Zeppelin" flies from Friedrichshafen, Germany, to Pernambuco, Brazil, and return.
- Apr. 19-28 C. W. A. Scott flies from Lympne, England, to Port Darwin, Australia, in 8 days, 20 hrs. 47 min., establishing new record. (DeHavilland Moth, DeHavilland Gipsy II motored.)
- Apr. 22 Cheney Award presented to Private John B. Smith and posthumously to Lieut. Robert D. Moor of the Army Air Corps.
- Apr. 28 Louis T. Reichers flies non-stop from Montreal, Canada, to Havana, Cuba, in 9 hrs. 3 min. (Lockheed Altair, Wright Cyclone motored.)
- May 2-10 "Graf Zeppelin" flies from Friedrichshafen, Germany, to Pernambuco, Brazil, and return.
- May 4 Daniel Guggenheim gold medal for 1932 awarded to Juan de la Cierva for the development of the autogiro.
- May 8-June 14 "U. S. S. Akron" flies to Pacific Coast and return.
- May 13 Louis T. Reichers is forced down at sea and rescued by steamship 47 miles west of Ireland on attempted trans-Atlantic flight. (Lockheed Altair, Wright Cyclone motored.)

- May 19-24 Dornier Do-X flies from New York to Berlin, Germany, via the Azores, Spain, and England. (Dornier Do-X flying boat, 12 Curtiss Conqueror motors.)
- May 20-21 Amelia Earhart Putnam flies from Harbor Grace, Nfld., to Londonderry, Ireland, in 15 hrs. 18 min. (Lockheed Vega, Pratt & Whitney Wasp motored.)
- May 22-26 International Congress of Transoceanic Fliers held in Rome, Italy.
- May 25 Annual conference of National Advisory Committee for Aeronautics held at Langley Field, Va.
- May 27-30 Second annual Omaha Air Races held at Omaha, Nebr.
- May 30 National Balloon Race won by Army balloon, piloted by Lieuts. Wilfred J. Paul and John H. Bishop, flying 901.4 miles from Omaha, Nebr., to Hatton, Saskatchewan, Canada.
- June 3 Stanislaus F. Hausner is forced down at sea on attempted trans-Atlantic flight from Floyd Bennett Field, Brooklyn, N. Y., and is rescued by a British tanker eight days later. (Bellanca Pacemaker, Wright Whirlwind motored.)
- June 15 American Airways inaugurates air mail service between Phoenix, Ariz., and San Diego, Cal.
- June 19-20 Lieut. Col. Andre L. F. Girier and Commandant Georges A. Rignot fly from Paris, France, to Teheran, Persia, covering approximately 2,500 miles in 29½ hrs. (Breguet 19 GR., Hispano-Suiza motored.)
- June 25 Thirteenth Royal Air Force Display held at Hendon, England.
- June 26 Daniel Guggenheim Airship Institute building dedicated at Akron, Ohio.
- July 5-6 James Mattern and Bennett Griffin fly non-stop from Harbor Grace, Nfld., to Berlin, Germany, in 18 hrs. 41 min., later continuing as far as Borisov, Russia, on an attempted flight around the world. (Lockheed Vega, Pratt & Whitney Wasp motored.)
- July 8-9 King's Cup Race won by W. L. Hope at Brooklands Aerodrome, England. (DeHavilland Fox Moth, DeHavilland Gipsy IIIA motored.)
- July 11-24 Third Annual National Soaring Meet held at Elmira, N. Y.
- July 12-13 Amelia Earhart Putnam flies from Los Angeles, Cal., to Newark, N. J., in 19 hrs. 15 min. elapsed time, or 17 hrs. 59 min. 40 sec. flying time, establishing new record for women. (Lockheed Vega, Pratt & Whitney Wasp motored.)
- July 18 J. K. O'Meara establishes American glider distance record of 66.61 miles from Elmira, N. Y., to Eatonville, Pa. (Darmstadt glider.)
- July 22-31 International Flying Meeting held at Zurich, Switzerland.
- July 24 Alberto Santos-Dumont dies in Sao Paulo, Brazil.
- July 24 J. K. O'Meara establishes glider altitude record of 4,780.169 ft. at Elmira, N. Y. (Darmstadt glider.)
- July 25 Maj. James H. Doolittle makes a 2,000 mile flight over routes covered by George Washington. (Lockheed Orion, Pratt & Whitney Wasp motored.)
- Aug. 14-22 Louise Thaden and Frances Marsalis establish refueling duration record for women of 8 days, 4 hrs. 5 min., at Valley Stream, N. Y. (Curtiss Thrush, Wright Whirlwind motored.)
- Aug. 18 Auguste Piccard, accompanied by Max Cosyns, establishes altitude record of 53,152.726 ft. in a hydrogen balloon above Switzerland and Italy.
- Aug. 18-19 Eleventh annual convention of National Aeronautic Association held in Washington, D. C.
- Aug. 18-21 Capt. James A. Mollison makes solo flight from Portmarnock Strand, Ireland, to Pennfield Ridge, New Brunswick, Canada, in about 30 hrs., later continuing to Roosevelt Field, Garden City, N. Y. (DeHavilland Puss Moth, DeHavilland Gipsy III motored.)
- Aug. 19 Maryse Hilsz establishes altitude record for women of 32,122.6 ft. at Villacoublay, France. (Morane 230, Bristol Jupiter motored.)
- Aug. 21-28 International Reliability Air Tour won by Lieut F. Zwirko. (R.W.D. 6, Armstrong Siddeley Genet-Major motored.)
- Aug. 23-Sept. 11 George Hutchinson, with his wife and two children and Peter Redpath, navigator, Joseph Ruff, mechanic, G. J. Altflisch, radio operator, and Norman W. Alley, photographer, flying from Floyd Bennett Field, Brooklyn, N. Y., on projected trans-Atlantic flight in short hops, is forced down off coast of Greenland and rescued two days later by British trawler. (Sikorsky amphibion, 2 Pratt & Whitney Wasp motors.)

- Aug. 24-25 Amelia Earhart Putnam flies non-stop from Los Angeles, Cal., to Newark, N. J., in 19 hrs. 5 min., establishing new record for women; also establishing women's distance record of 2,447.8 miles. (Lockheed Vega, Pratt & Whitney Wasp motored.)
- Aug. 25 Clyde A. Lee and John Bochkon, flying from Harbor Grace, Nfld., on projected flight to Norway, are lost at sea. (Stinson Detroit, Wright Whirlwind motored.)
- Aug. 27-Sept. 5 National Air Races held at Cleveland, Ohio.
- Aug. 29 James G. Haizlip flies from Los Angeles, Cal., to Floyd Bennett Field, Brooklyn, N. Y., in 10 hrs. 19 min., establishing transcontinental record. (Wedell-Williams, Pratt & Whitney Wasp Junior motored.)
- Aug. 29 Col. Roscoe Turner flies from Los Angeles, Cal., to Floyd Bennett Field, Brooklyn, N. Y., in 10 hrs. 58 min. (Wedell-Williams, Pratt & Whitney Wasp Junior motored.)
- Aug. 29-Sept. 6 "Graf Zeppelin" flies from Friedrichshafen, Germany, to Pernambuco, Brazil, and return.
- Sept. 3 Maj. James H. Doolittle establishes speed record for land planes of 294.38 m.p.h. at Cleveland, Ohio. (Granville Gee Bee Super-Sportster, Pratt & Whitney Wasp motored.)
- Sept. 5 Mae Haizlip establishes speed record for women of 252.226 m.p.h. at Cleveland, Ohio. (Wedell-Williams, Pratt & Whitney Wasp Junior motored.)
- Sept. 5-9 Annual Conference of Fédération Aéronautique Internationale held at The Hague, Netherlands.
- Sept. 13 William Ulbrich, pilot, with Dr. Leon M. Pisculli and Edna Newcomer, passengers, flying from Floyd Bennett Field, Brooklyn, N. Y., on attempted trans-Atlantic flight, is lost at sea. (Bellanca Skyrocket, Pratt & Whitney Wasp motored.)
- Sept. 13-21 "Graf Zeppelin" flies from Friedrichshafen, Germany, to Pernambuco, Brazil, and return.
- Sept. 16 Cyril F. Uwins establishes altitude record for land planes of 43,976.245 ft. at Bristol, England. (Vickers Vespa, Bristol Pegasus S-3 motored.)
- Sept. 23 Eichiro Baba, pilot, Kiyoshi Homma, navigator, and Tomoyoshi Inoshita, radio operator, flying from Samushiro, Japan, on attempted trans-Pacific flight, are lost at sea. (Junkers W.-33, Junkers L-5 motored.)
- Sept. 25 Capt. Lewis A. Yancey establishes autogiro altitude record of 21,500 ft. at Boston, Mass. (Pitcairn PCA-2, Wright Whirlwind motored.)
- Sept. 26-Oct. 4 "Graf Zeppelin" flies from Friedrichshafen, Germany, to Pernambuco, Brazil, and return.
- Sept. 27 U. S. Navy Balloon, piloted by Lieut. T. G. W. Settle, wins Gordon Bennett Cup Race, flying 963 miles from Basel, Switzerland, to Daugieliszki, Poland.
- Oct. 9-19 "Graf Zeppelin" flies from Friedrichshafen, Germany, to Pernambuco, Brazil, and return.
- Oct. 23 James Wedell flies from Ottawa, Canada, to Mexico City, Mexico, in 11 hrs. 53 min. elapsed time. (Wedell-Williams, Pratt & Whitney Wasp Junior motored.)
- Oct. 24-Nov. 3 "Graf Zeppelin" flies from Friedrichshafen, Germany, to Pernambuco, Brazil, and return.
- Nov. 14 Col. Roscoe Turner flies from Floyd Bennett Field, Brooklyn, N. Y., to Burbank, Cal., in 12 hrs. 33 min., establishing new East-West record. (Wedell-Williams, Pratt & Whitney Wasp Junior motored.)
- Nov. 14-18 Amy Johnson Mollison flies from Lympne, England, to Cape Town, South Africa, in 4 days, 6 hrs. 54 min., establishing new record. (DeHavilland Puss Moth, DeHavilland Gipsy Major motored.)
- Nov. 18-Dec. 4 Thirteenth International Aero Exhibition held at Paris, France.
- Nov. 19 National monument to Wilbur and Orville Wright dedicated at Kitty Hawk, N. C.
- Nov. 23 Capt. Wolfgang von Gronau, with Fritz Albrecht, Franz Hack, and Gert von Roth, completes flight around the world, having left List, Island of Sylt, North Sea, on July 22. (Dornier-Wal, 2 B.M.W. VII motors.)
- Dec. 1 Eastern Air Transport inaugurates air mail service between Charlotte, N. C., and Augusta, Ga.
- Dec. 11-18 Amy Johnson Mollison flies from Cape Town, South Africa, to London, England, in 7 days, 7 hrs. 5 min., establishing new record. (DeHavilland Puss Moth, DeHavilland Gipsy Major motored.)

OFFICIAL WORLD AND AMERICAN AIR RECORDS

Established Under Rules and Regulations of the

FEDERATION AERONAUTIQUE INTERNATIONALE

Translated and Compiled by the Contest Committee, National Aeronautic Association, Washington, D. C.

December 31, 1932

WORLD RECORDS

CONFIRMED BY FEDERATION AERONAUTIQUE INTERNATIONALE

AMERICAN RECORDS

CONFIRMED BY CONTEST COMMITTEE NATIONAL AERONAUTIC ASSOCIATION OF U. S. A.

AIRPLANES—Class C

RETURNING TO POINT OF DEPARTURE WITHOUT REFUELING

Duration (Closed Circuit) (United States)—Walter E. Lees and F. A. Brossy, Bellanca monoplane, Packard Diesel 225 HP, at Jacksonville Beach, Fla., May 25-28, 1931. Time, 84H, 32M.

Distance (Closed Circuit) (France)—Lucien Bossoutrot and Maurice Rossi, Bleriot 110 monoplane, Hispano-Suiza 500 HP, at Oran, Algeria, March 23-26, 1932. Distance, 10,601.480 Kilo. (6,587.442 Miles).

Distance (Airline) (United States)—Russell N. Boardman and John Polando, Bellanca monoplane, Wright J-6 300 HP, from Brooklyn, N. Y., to Istanbul, Turkey, July 28-30, 1931.

Distance, 8,065.736 Kilo. (5,011.8 Miles).
Altitude (Great Britain)—Capt. Cyril Frank Uwins, Vickers Vespa landplane, Bristol Pegasus S.3, at Filton, Bristol, September 16, 1932.

Height, 13,404 Meters (43,976.245 Feet).
Maximum Speed (United States)—James H. Doolittle, Granville Gee Bee monoplane, Pratt & Whitney Wasp 800 HP, at Cleveland, O., September 3, 1932. Speed, 473.82 KPH (294.38 MPH).

World and American Record.

Distance (Closed Circuit)—Lts. Kelly and Macready, U. S. A., T-2, Liberty 375 HP, at Wright Field, Dayton, O., April 16-17, 1923. Distance, 4,050 Kilo. (2,516.55 Miles).

World and American Record.

Altitude—Lieut. Apollo Soucek, Wright Apache landplane, Pratt & Whitney 450 HP, at Anacostia, D. C. June 4, 1930. Height, 13,157 Meters (43,166 Feet).

World and American Record.

SPEEDS FOR SPECIFIED DISTANCES WITHOUT PAY LOAD

Speed for 100 Kilometers (United States)—Lt. Cyrus Bettis, U. S. A. S., Curtiss R3C-1, Curtiss V-1400 HP, at Mitchel Field, L. I., N. Y., October 12, 1925. Speed, 401.279 KPH (249.342 MPH).

Speed for 500 Kilometers (France)—Louis Massotte, Bleriot-Spad biplane, Hispano-Suiza 500 HP, Villesauvage-LaMarmogne course, June 27, 1932. Speed, 308.779 KPH (191.866 MPH).

Speed for 1,000 Kilometers (France)—Marcel Doret, Dewoitine type 26, No. 7 Hispano-Suiza 500 HP, Villesauvage-LaMarmogne course, November 30, 1930. Speed, 286.227 KPH (177.853 MPH).

Speed for 2,000 Kilometers (France)—M. Haegelen, Lorraine-Hanriot, Lorraine 230 HP, Etampes-Mesvres sur Loire course, August 12, 1932. Speed, 263.900 KPH (163.979 MPH).

Speed for 5,000 Kilometers (Spain)—Carlos de Haya Gonzales and Cirpiano Rodriguez Diaz, Breguet, Hispano-Suiza 600 HP, Seville-Utrera-Carmona course, October 7-8, 1930. Speed, 208.152 KPH (130.189 MPH).

World and American Record.

Speed for 500 Kilometers—Lt. Alex Pearson, U. S. A., Verville Sperry R-3, Wright 350 HP, at Wright Field, Dayton, O., March 29, 1923. Speed, 270.06 KPH (167.80 MPH).

Speed for 1,000 Kilometers—Lt. Harold R. Harris, U. S. A., and Ralph Lockwood, DH-4L, Liberty 400 HP, at Wright Field, Dayton, O., March 29, 1923. Speed, 205.06 KPH (127.42 MPH).

Speed for 2,000 Kilometers—Lt. Harold R. Harris, U. S. A., DH-4L, Liberty 375 HP, at Wright Field, Dayton, O., April 17, 1923. Speed, 183.83 KPH (114.22 MPH).

(No Record.)

CLASS C—WITH PAY LOAD OF 500 KILOGRAMS

(1,102.31 Lbs.)

WORLD RECORDS

Duration (Closed Circuit) (France)—J. LeBrix and M. Doret, "The Hyphen" Dewoitine, Hispano-Suiza 600 HP, at Istres, March 23-24, 1931.
Time, 32H, 17M.

Distance (Closed Circuit) (France)—J. LeBrix and M. Doret, "The Hyphen" Dewoitine, Hispano-Suiza 600 HP, at Istres, March 23-24, 1931.
Distance, 4,670.664 Kilo. (2,902.210 Miles).

Altitude (France)—M. Signerin, Breguet 198, Gnome-Rhone 620 HP, at Villacoublay, September 21, 1932.
Height, 10,285 Meters (33,743.334 feet)

AMERICAN RECORDS

Duration—Lt. H. R. Harris, U. S. A. S., Douglas DT-2, Liberty 400 HP, at Wright Field, Dayton, O., June 28, 1924.
Time, 9H, 11M, 53.4S.

Distance—Lt. H. R. Harris, U. S. A. S., Douglas DT-2, Liberty 400 HP, at Wright Field, Dayton, O., June 28, 1924.
Distance, 950 Kilo. (590.3 Miles).

Altitude—Lt. H. R. Harris, U. S. A. S., USA-TP-1, Liberty 400 HP, at Wright Field, Dayton, O., May 21, 1924.
Height, 8,578 Meters (28,143 Feet).

SPEEDS FOR SPECIFIED DISTANCES

Speed for 100 Kilometers (United States)—Leland F. Shoenhair, Lockheed Vega "Executive" monoplane, Pratt & Whitney 450 HP supercharged, at Jacksonville, Fla., February 18, 1930.
Speed, 298.510 KPH (185.49 MPH).

Speed for 500 Kilometers (France)—Lemoine, Potez 503, Gnome-Rhone 700 HP, Villacoublay-Angers course, September 16, 1932.
Speed, 294.194 KPH (182.803 MPH).

Speed for 1,000 Kilometers (Czechoslovakia)—Capt. Joseph Kalla, Letov S 516, Asso 800 HP, Praha-Nove Benatky Rip-Praha course, October 12, 1930.
Speed, 275.269 KPH (171.044 MPH).

Speed for 2,000 Kilometers (France)—Lt. de Vaisseau Paris, Latécoère 28, Hispano-Suiza 650 HP, at Toulouse, April 11, 1931.
Speed 228.267 KPH (141.838 MPH).

Speed for 5,000 Kilometers—(No Record).

World and American Record.

Speed for 500 Kilometers—Leland F. Shoenhair, Lockheed Vega "Executive" monoplane, Pratt & Whitney 450 HP supercharged, at Jacksonville, Fla., February 18, 1930.
Speed, 275.580 KPH (171.24 MPH).
(No Record.)

(No Record.)

(No Record.)

(No Record.)

CLASS C—WITH PAY LOAD OF 1,000 KILOGRAMS

(2,204.12 Lbs.)

RETURNING TO POINT OF DEPARTURE

WORLD RECORDS

Duration (Closed Circuit) (France)—J. LeBrix and M. Doret, "The Hyphen" Dewoitine, Hispano-Suiza 600 HP, at Istres, March 23-24, 1931.
Time, 32H, 17M.

Distance (Closed Circuit) (France)—J. LeBrix and M. Doret, "The Hyphen" Dewoitine, Hispano-Suiza 600 HP, at Istres, March 23-24, 1931.
Distance, 4,670.664 Kilo. (2,902.210 Miles).

Altitude (France)—M. Signerin, Breguet 198, Gnome-Rhone 620 HP, at Villacoublay, September 23, 1932.
Height, 8,980 Meters (29,461.853 Feet).

AMERICAN RECORDS

Duration—Lt. J. S. Macready, U. S. A. S., Curtiss (Martin) Bomber, NBS 1, 2 Liberty 400 HP, at Wright Field, Dayton, O., October 2, 1924.
Time, 2H, 13M, 49.6S.
(No Record.)

Altitude—Waldo Waterman, Bach landplane, Wright J-6, at Los Angeles Metropolitan Airport, Los Angeles, Cal., July 26, 1929.
Height, 6,346 Meters (20,820 Feet).

SPEEDS FOR SPECIFIED DISTANCES

- | | |
|--|--|
| Speed for 100 Kilometers (United States)—
Leland F. Schoenhair, Lockheed Vega
"Executive" monoplane, Pratt & Whitney
450 HP supercharged, at Jacksonville, Fla.,
February 20, 1930.
Speed, 283.250 KPH (176 MPH). | World and American Record. |
| Speed for 500 Kilometers (France)—Lemoine,
Potez 503, Gnome-Rhone 700 HP, Villacou-
blay-Angers course, September 16, 1932.
Speed, 294.194 KPH (182.803 MPH). | Speed for 500 Kilometers—Leland F. Schoen-
hair, Lockheed Vega "Executive" mono-
plane, Pratt & Whitney 450 HP super-
charged, at Jacksonville, Fla., February 20,
1930.
Speed, 270.800 KPH (168.27 MPH). |
| Speed for 1,000 Kilometers (Czechoslovakia)
—Adj. Vojtech Svozil, Aero A-42, Asso
800 HP, Praha-Nove Benatky Rip-Praha
course, September 20, 1930.
Speed, 252.380 KPH (156.821 MPH). | Speed for 1,000 Kilometers—Leland F.
Schpenhair, Lockheed Vega "Executive"
monoplane, Pratt & Whitney 450 HP super-
charged, at Jacksonville, Fla., February 20,
1930.
Speed, 245.750 KPH (152.70 MPH). |
| Speed for 2,000 Kilometers (France)—Lt. de
Vaisseau Paris, Latécoère 28, Hispano-
Suiza 650 HP, at Toulouse, April 11, 1931.
Speed, 228.267 KPH (141.838 MPH). | (No Record.) |
| Speed for 5,000 Kilometers—(No Record). | (No Record.) |

CLASS C—WITH PAY LOAD OF 2,000 KILOGRAMS

(4,409.24 Lbs.)

RETURNING TO POINT OF DEPARTURE

WORLD RECORDS

- Duration (France)—J. LeBrix and M. Doret,
"Le Trait d'Union" Dewoitine, Hispano-
Suiza 600 HP, at Istres, March 23-24, 1931.
Time, 32H, 17M, 48S.
- Distance (Closed Circuit) (France)—J. Le
Brix and M. Doret, "Le Trait d'Union"
Dewoitine, Hispano-Suiza 600 HP, at Istres,
March 23-24, 1931.
Distance, 4,670.664 Kilo. (2,902.210 Miles).
- Altitude (France)—Lucien Coupet, Farman
160 biplane No. 3, 2 Farman 500 HP ea., at
Toussus-le-Noble, April 28, 1931.
Height, 7,507 Meters (24,629.215 Feet).

AMERICAN RECORDS

- Duration—Lt. H. R. Harris, U. S. A. S., and
Mechanician Doug. Culver, Barling
Bomber, 6 Liberty 400 HP, at Wright
Field, Dayton, O., October 3, 1924.
Time, 1H, 47M, 10.5S.
(No Record.)
- Altitude—Lt. H. R. Harris, U. S. A. S., Barling
Bomber, 6 Liberty 400 HP ea., at Wright
Field, Dayton, O., October 25, 1923.
Height, 2,049 Meters (6,722 Feet).

SPEEDS FOR SPECIFIED DISTANCES

- | | |
|--|----------------------------|
| Speed for 100 Kilometers (United States)—
Leroy Manning and Carl Wenzel, Ford
Transport, 3 Pratt & Whitney Wasp 425
HP ea., at Dearborn, Mich., September 29,
1930.
Speed, 264.628 KPH (164.432 MPH). | World and American Record. |
| Speed for 500 Kilometers (France)—Dubour-
dieu, Latécoère 28-2 monoplane, Hispano-
Suiza 650 HP, at Toulouse, March 29, 1931.
Speed, 226.073 KPH (140.475 MPH). | (No Record.) |
| Speed for 1,000 Kilometers (France)—Du-
bourdieu, Latécoère 28-2 monoplane, His-
pano-Suiza 650 HP, at Toulouse, March 29,
1931.
Speed, 224.733 KPH (139.642 MPH). | (No Record.) |
| Speed for 2,000 Kilometers (France)—J. Le
Brix and M. Doret, "Le Trait d'Union"
Dewoitine, Hispano-Suiza 600 HP, at
Istres, March 23-24, 1931.
Speed, 151.362 KPH (94.052 MPH). | (No Record.) |
| Speed for 5,000 Kilometers—(No Record). | (No Record.) |

CLASS C—WITH PAY LOAD OF 5,000 KILOGRAMS

(11,023 Lbs.)

WORLD RECORDS

AMERICAN RECORDS

- Duration (Germany)—Wilhelm Zimmerman, (No Record.)
 Junkers J-38, 2 Junkers L-55, 600 HP ea., 2
 Junkers L-8, 400 HP ea., at Dessau-
 Leipzig, April 10, 1930.
 Time, 3H, 2M.
- Distance (Germany)—Wilhelm Zimmerman, (No Record.)
 Junkers J-38 monoplane, 2 Junkers L-55,
 600 HP ea., 2 Junkers L-8, 400 HP ea., at
 Dessau-Leipzig, April 10, 1930.
- Distance, 501.590 Kilo. (311.6724 Miles).
- Altitude (France)—L. Bossoutrot, super Far- (No Record.)
 man-Goliath, 4 Farman 500 HP ea., at Le
 Bourget, November 16, 1925.
 Height, 3,586 Meters (11,765 Feet).

SPEEDS FOR SPECIFIED DISTANCES

- Speed for 100 Kilometers (Germany)—Wil- (No Record.)
 helm Zimmerman, Junkers J-38, 2 Junkers
 L-55, 600 HP ea., 2 Junkers L-8, 400 HP
 ea., at Dessau-Leipzig, April 10, 1930.
 Speed, 184.464 KPH (114.62 MPH).
- Speed for 500 Kilometers (Germany)—Wil- (No Record.)
 helm Zimmerman, Junkers J-38, 2 Junkers
 L-55, 600 HP ea., 2 Junkers L-8, 400 HP ea.,
 at Dessau-Leipzig, April 30, 1930.
 Speed, 172.950 KPH (107.466 MPH).
- Speed for 1,000 Kilometers—(No Record.) (No Record.)
 Speed for 2,000 Kilometers—(No Record.) (No Record.)
 Speed for 5,000 Kilometers—(No Record.) (No Record.)

CLASS C—WITH PAY LOAD OF 10,000 KILOGRAMS

WORLD RECORDS

AMERICAN RECORDS

- Duration (Italy)—Cav. Domenico Antonini (No Record.)
 Caproni, Ca 90 biplane, 6 Isotta-Fraschini
 Asso 1,000 HP ea., at Cascina Malpensa,
 February 22, 1930.
 Time, 1H, 31M.
- Altitude (Italy)—Cav. Domenico Antonini (No Record.)
 Caproni, Ca 90 biplane, 6 Isotta-Fraschini
 Asso 1,000 HP ea., at Cascina Malpensa,
 February 22, 1930.
 Height, 3,231 Meters (10,597 Feet).
- Distance—(No Record.) (No Record.)

SPEEDS FOR SPECIFIED DISTANCES

- Speed for 100 Kilometers—(No Record.) (No Record.)
 Speed for 500 Kilometers—(No Record.) (No Record.)
 Speed for 1,000 Kilometers—(No Record.) (No Record.)
 Speed for 2,000 Kilometers—(No Record.) (No Record.)
 Speed for 5,000 Kilometers—(No Record.) (No Record.)

CLASS C—GREATEST PAY LOAD CARRIED TO AN ALTITUDE OF
 2,000 METERS

(6,671.7 Feet)

WORLD RECORDS

AMERICAN RECORDS

- (Italy)—Cav. Domenico Antonini Caproni, Lt. H. R. Harris, U. S. A. S., Barling Bomber,
 Ca 90 biplane, 6 Isotta-Fraschini Asso 6 Liberty 400 HP ea., at Wright Field,
 1,000 HP ea., at Cascina Malpensa, Feb- Dayton, O., October 25, 1923.
 ruary 22, 1930. Weight, 2,000 Kgs. (4,409 Lbs.).
 Weight, 10,000 Kgs. (22,046 Lbs.).

AIRPLANES—CLASS C—REFUELING IN FLIGHT

RETURNING TO POINT OF DEPARTURE

WORLD RECORDS

AMERICAN RECORDS

- Duration (United States)—John and Kenneth Hunter, Stinson Detrioter, Wright-Whirlwind 300 HP, at Sky Harbor, Northbrook, Ill., June 11, 1930—July 4, 1930.
Time, 553H, 41M, 30S. World and American Record.
- Distance (United States)—Lts. Smith and Richter, U. S. A., DH-4-B, Liberty 400 HP, at Rockwell Field, San Diego, Cal., August 27-28, 1923. World and American Record.
Distance, 5,300 Kilo. (3,293.26 Miles).

AIRPLANES—CLASS C—WOMEN'S CATEGORY

WORLD RECORDS

AMERICAN RECORDS

- Duration (France)—Mme. Maryse Bastie, Klemm, Salmson 40 HP, at Le Bourget, September 2-4, 1930. (No Record.)
Time, 37H, 55M.
- Duration with Refueling in Flight (United States)—Mrs. Louise Thaden and Mrs. Frances Marsalis, Curtiss Thrush, Wright J-6-E 240 HP, at Valley Stream, L. I., N. Y., August 14-22, 1932. World and American Record.
Time, 196H, 5M.
- Distance (Airline) (United States)—Mrs. Amelia Earhart Putnam, Lockheed Vega, Pratt & Whitney Wasp 450 HP, Los Angeles, Cal., to Newark, N. J., August 24-25, 1932. World and American Record.
Distance, 2,447.8 Miles.
- Altitude (France)—Mademoiselle Maryse Hilsz, Moraine-Saulnier, Gnome and Rhone 420 HP, at Villacoublay, August 19, 1932. Altitude—Ruth Nichols, Lockheed Vega, Pratt & Whitney Wasp 420 HP, at Jersey City Airport, N. J., March 6, 1931.
Height, 9,791 Meters (32,122.606 Feet). Height, 8,761 Meters (28,743 Feet).
World and American Record.
- Speed (United States)—Mrs. May Haizlip, Wedell-Williams, Pratt & Whitney Wasp Junior 540 HP, at Cleveland, O., September 5, 1932. World and American Record.
Speed, 405.92 KPH (252.226 MPH).
- Speed for 100 Kilometers (United States)—Mrs. Amelia Earhart Putnam, Lockheed Vega monoplane, Pratt & Whitney Wasp 420 HP, at Detroit, Mich., June 25, 1930. World and American Record.
Speed, 281.470 KPH (174.897 MPH).

WITH PAY LOAD OF 500 KILOGRAMS

WORLD RECORDS

AMERICAN RECORDS

- Speed for 100 Kilometers (United States)—Mrs. Amelia Earhart Putnam, Lockheed Vega monoplane, Pratt & Whitney Wasp 420 HP, at Detroit, Mich., June 25, 1930. World and American Record.
Speed, 275.904 KPH (171.438 MPH).

LIGHT AIRPLANES—THIRD CATEGORY

WORLD RECORDS

AMERICAN RECORDS

- Distance (Airline) (France)—Mme. Maryse Bastie, Klemm, Salmson 40 HP, Le Bourget to Urino, Russia, June 28-29, 1931. (No Record.)
Distance, 2,976.910 Kilo. (1,849.763 Miles).
- Altitude (United States)—Mrs. May Haizlip, Buhl Bull Pup, Szekely 85 HP, at St. Clair, Mich., June 13, 1931. World and American Record.
Height, 5,516 Meters (18,097 Feet).

LIGHT AIRPLANES—CLASS C—FIRST CATEGORY

Two seaters weight empty less than 400 Kgs. (881 Lbs.)

WORLD RECORDS

AMERICAN RECORDS

- Duration (Closed Circuit) (France)—Freton and de La Vergne, Farman 231, Renault 95 HP, Istres-Nimes and Fosses Jumeaux-Arles course, April 8-9, 1931. Time, 29H, 38M. (No Record.)
- Distance (Closed Circuit) (France)—Freton and de La Vergne, Farman 231, Renault 95 HP, Istres-Nimes and Fosses Jumeaux-Arles course, April 8-9, 1931. Distance, 3,465.211 Kilo. (2,153.178 Miles). (No Record.)
- Distance (Airline) (France)—Lalouette and de Permangle, Farman 231, Renault 95 HP, Istres airport to Villa-Cisneros, January 11-12, 1931. Distance, 2,912 Kilo. (1,809.429 Miles). (No Record.)
- Altitude (Germany)—Woldemar Voigt and K. H. Gaule, Akademische Fliegergruppe Darmstadt, D-18, Armstrong Siddeley, Genet Major 100 HP, at Darmstadt, April 21, 1930. Height, 7,521 Meters (24,672 Feet). Altitude—Willfred G. Moore, Inland Sport monoplane, Warner 110 HP, at Kansas City, Mo., September 30, 1929. Height, 5,652 Meters (18,543 Feet).

SPEEDS FOR SPECIFIED DISTANCES

- Speed over 100 Kilometers (France)—Freton and de La Vergne, Farman 230, Renault 95 HP, Villesauvage-La Marmogne course, June 27, 1931. Speed, 223.546 KPH (138.905 MPH).
- Speed for 100 Kilometers—Willfred G. Moore, pilot; W. S. Glodfelty, passenger; Inland Sport monoplane, Warner 110 HP, at Kansas City, Mo., February 12, 1930. Speed, 204.313 KPH (126.95 MPH).

CLASS C—SECOND CATEGORY

Two seaters weight empty less than 280 Kgs. (617 Lbs.)

WORLD RECORDS

AMERICAN RECORDS

- Duration (Closed Circuit) (Roumania)—Eng. J. Cociasu and G. Grozea, Klemm, Daimler 20 HP, at Bucharest, July 2, 1932. Time, 8H, 17M. (No Record.)
- Distance (Closed Circuit) (France)—Reginensi and de Viscaya, Farman 230, Salmson 40 HP, Villesauvage-La Marmogne course, December 27, 1930. Distance, 1,000 Kilo. (621.37 Miles). (No Record.)
- Distance (Airline) (France)—Reginensi and Lecoite, Farman 230, Salmson 40 HP, Toussus-le-Noble to Marignane (Marseilles), February 18, 1931. Distance, 636.050 Kilo. (395.222 Miles). (No Record.)
- Altitude (Poland)—Inj. J. Drzewiecki and A. Koejan, R. W. D. 7, Genet 80 HP, at Lotnisko, Varsovie, September 30, 1932. Height, 6,023 Meters (19,760.439 Feet). Altitude—Edna Rudolph, pilot; Thornton Waggoner, passenger; Curtiss Wright Junior, Szekely 43 HP, at East St. Louis, Ill., May 31, 1931. Height, 4,244 Meters (13,924 Feet).

SPEEDS FOR SPECIFIED DISTANCES

- Speed for 100 Kilometers (Poland)—Ing. Georges Drzewiecki and G. Wedrychowski, W. R. D. 7 monoplane, Genet 80 HP, at Varsovie-Skierniewice, August 12, 1931. Speed, 178.748 KPH (111.069 MPH). (No Record.)

CLASS C—THIRD CATEGORY

Single seaters weight empty 200-350 Kgs., Inc. (440-771 Lbs.)

WORLD RECORDS

AMERICAN RECORDS

- | | |
|--|---|
| Duration (France)—Madame Maryse Bastie, Klemm, Salmson 40 HP, at Le Bourget, September 2-4, 1930.
Time, 37H, 55M. | (No Record.) |
| Distance (Closed Circuit) (France)—Laulhe, Albert, Salmson 40 HP, at Le Bourget, September 4-5, 1930.
Distance, 2,714.400 Kilo. (1,686.646 Miles). | (No Record.) |
| Distance (Airline) (France)—Madame Maryse Bastie, Klemm, Salmson 40 HP, Le Bourget to Urino, Russia, June 28-29, 1931.
Distance, 2,976.910 Kilo. (1,849.763 Miles). | Distance (Airline)—D. S. Zimmerly, Barling NB-3, LeBlond 60 HP, Brownsville, Tex., to Winnipeg City, Canada, July 17, 1929.
Distance, 2,655 Kilo. (1,650 Miles). |
| Altitude (Germany)—Woldemar Voigt, Akademische Fliegergruppe Darmstadt D-18, Armstrong Siddeley Genet Major 100 HP, at Darmstadt, May 23, 1930.
Height, 8,142 Meters (26,712 Feet). | Altitude—D. S. Zimmerly, Barling NB-3 monoplane, Lambert R266 90 HP, at Forest Park Flying Field, St. Louis, Mo., February 16, 1930.
Height, 7,338 Meters (24,074 Feet). |

SPEEDS FOR SPECIFIED DISTANCES

- | | |
|--|--------------|
| Speed for 100 Kilometers (Great Britain)—Capt. H. S. Broad, DH Tiger Moth, DH 32 130 HP, at Stage Lane, August 24, 1927.
Speed, 300.1 KPH (186.47 MPH). | (No Record.) |
|--|--------------|

CLASS C—FOURTH CATEGORY

Single seaters weight empty less than 200 Kgs. (440 Lbs.)

WORLD RECORDS

AMERICAN RECORDS

- | | |
|--|--|
| Duration (France)—G. Fauvel, Peyret-Mauboussin, A. B. C. Scorpion 34 HP, at Le Bourget, September 12, 1930.
Time, 12H, 3M. | (No Record.) |
| Distance (Closed Circuit) (France)—G. Fauvel, Peyret-Mauboussin, A. B. C. Scorpion 34 HP, at Le Bourget, September 12, 1930.
Distance, 1,258.800 Kilo. (782.180 Miles). | (No Record.) |
| Distance (Airline) (France)—G. Fauvel, Peyret-Mauboussin Type 10, A. B. C. Scorpion, at Le Bourget, September 6, 1929.
Distance, 852.100 Kilo. (529.40 Miles). | (No Record.) |
| Altitude (France)—G. Fauvel, Peyret-Mauboussin Type 10, A. B. C. Scorpion, at Le Bourget, September 5, 1929.
Height, 5,193 Meters (17,037 Feet). | Altitude—Kenneth W. Scholter, Aeronca, Aeronca 38 HP, at Detroit, Mich., April 12, 1931.
Height, 5,324 Meters (17,467 Feet).
(Note: F. A. I. requirement that previous record be beaten by 200 meters in order to establish new international mark prevents international recognition of this record.)
World and American Record. |
| Speed for 100 Kilometers (United States)—Clarence O. Prest, Prest Baby Pursuit, Szekely 40 HP, San Bernardino Co., Cal., May 28, 1930.
Speed, 162.94 KPH (101.24 MPH). | |

SEAPLANES—CLASS C2

RETURNING TO POINT OF DEPARTURE WITHOUT REFUELING

WORLD RECORDS

- Duration (France)—Lt. de Vaisseau Paris and M. Gonord, Latécoère 28-3, Hispano-Suiza 600 HP, at Arcachon, June 4-5, 1931. Time, 36H, 57M.
- Distance (Closed Circuit) (France)—Lt. de Vaisseau Paris and M. Gonord, Latécoère 28-3, Hispano-Suiza 600 HP, at Arcachon, June 4-5, 1931. Distance, 5,011.210 Kilo. (3,113.816 Miles).
- Distance (Airline) (France)—Mermoz, Darby and Gimie, Latécoère 28, Hispano-Suiza 600 HP, St. Louis, Senegal to Natal, Brazil, May 12-13, 1930. Distance, 3,173.200 Kilo. (1,971.7310 Miles).
- Altitude (United States)—Lt. Apollo Soucek, U. S. N., Wright "Apache," Pratt & Whitney 425 HP supercharged, at Washington, D. C., June 4, 1929. Height, 11,753 Meters (38,560 Feet).
- Maximum Speed (Great Britain)—Flight—Lt. G. H. Stainforth, Vickers Supermarine S6B, Rolls Royce R, at Lee-on-Solent, September 29, 1931. Speed, 655 KPH (406.997 MPH).

AMERICAN RECORDS

- Duration—Lts. Arthur Gavin and Zeus Soucek, Navy PN-12, 2 Wright R-1750, 525 HP ea., at Philadelphia, Pa., May 3-5 1928. Time, 36H, 1M.
- Distance—Lts. B. J. Connell and H. C. Rodd, PN-10, 2 Packard 600 HP ea., at San Diego, Cal., August 15-16, 1927. Distance, 2,525 Kilo. (1,569 Miles).
- Distance (Airline)—Comdr. John Rodgers, U. S. N., and Lt. B. J. Connell, PN-9, 2 Packard 1-A-1500, 500 HP ea., San Pablo Bay, Cal., to near Hawaii, August 31-September 1, 1925. Distance, 2,963 Kilo. (1,841 Miles). World and American Record.
- Maximum Speed—Lt. Jas. H. Doolittle, U. S. A. S., Curtiss R3C-2, Curtiss V-1400, 600 HP, at Bay Shore, Baltimore, Md. October 27, 1925. Speed, 395.439 KPH (245.713 MPH).

SPEEDS FOR SPECIFIED DISTANCES

- Speed for 100 Kilometers (Great Britain)—Flight—Lt. J. N. Boothman, R. A. F., Vickers Supermarine S6B, Rolls Royce R, at Spithead, September 13, 1931. Speed, 551.800 KPH (342.871 MPH).
- Speed for 500 Kilometers (United States)—Lt. R. A. Ofstie, Curtiss Navy C-3, Curtiss D-12 450 HP, at Bay Shore, Baltimore, Md., October 25, 1924. Speed, 259.328 KPH (161.14 MPH).
- Speed for 1,000 Kilometers (Germany)—Rolf Starke, Heinkel HE9, BMW, VI 600 HP, at Warnemunde, June 10, 1929. Speed, 222.277 KPH (138.116 MPH).
- Speed for 2,000 Kilometers (France)—Lt. de Vaisseau Paris and M. Hebert, Latécoère 28, Hispano-Suiza 600 HP, at St. Laurent de la Salanque, June 23, 1930. Speed, 185.931 KPH (117.396 MPH).
- Speed for 5,000 Kilometers (France)—Lt. de Vaisseau Paris and M. Gonord, Latécoère 28-3, Hispano-Suiza 600 HP, at Arcachon, June 4-5, 1931. Speed, 139.567 KPH (86.723 MPH).
- Speed for 100 Kilometers—Lt. G. T. Cuddihy, U. S. N., Curtiss R3C-2, Curtiss V-1550, 700 HP, at Norfolk, Va., November 13, 1926. Speed, 388.944 KPH (241.679 MPH). World and American Record.
- Speed for 1,000 Kilometers—Lt. R. Irvine, Vought Corsair, Pratt & Whitney Wasp 425 HP, at Hampton Roads, Va., May 21, 1927. Speed, 210.716 KPH (130.932 MPH).
- Speed for 2,000 Kilometers—Lts. B. J. Connell and H. C. Rodd, U. S. N., PN-10, 2 Packard 600 HP ea., at San Diego, Cal., August 15-16, 1927. Speed, 126.567 KPH (78.644 MPH). (No Record.)

CLASS C2—WITH PAY LOAD OF 500 KILOGRAMS (1,102.31 Lbs.)

RETURNING TO POINT OF DEPARTURE

WORLD RECORDS

- Duration (France)—Lt. de Vaisseau Paris and M. Hebert, Latécoère 28, Hispano-Suiza 600 HP, at St. Laurent de la Salanque, June 23, 1930. Time, 31H, 1M.
- Distance (France)—Lt. de Vaisseau Paris and M. Hebert, Latécoère 28, Hispano-Suiza 600 HP, at St. Laurent de la Salanque, July 17, 1930. Distance, 4,202.496 Kilo. (2,611.305 Miles).
- Altitude (United States)—Boris Sergievsky, Sikorsky S-38, 2 Pratt & Whitney Wasp 420 HP ea. supercharged, at Bridgeport, Conn., July 21, 1930. Height, 8,208 Meters (26,929.080 Feet).

AMERICAN RECORDS

- Duration—Lts. B. J. Connell and H. C. Rodd, PN-10, 2 Packard 600 HP ea., at San Diego, Cal., August 15-16, 1927. Time, 20H, 45M, 40S.
- Distance—Lts. B. J. Connell and H. C. Rodd, PN-10, 2 Packard 600 HP ea., at San Diego, Cal., August 15-16, 1927. Distance, 2,525 Kilo. (1,569 Miles). World and American Record.

SPEEDS FOR SPECIFIED DISTANCES

- Speed for 100 Kilometers (Germany)—Rolf Starke, Heinkel HD-38, BMW-6 600 HP, at Warnemunde, May 7, 1929.
Speed, 259.927 KPH (161.510 MPH).
- Speed for 500 Kilometers (Germany)—Rolf Starke, Heinkel HE-9a, BMW-6 600 HP, at Warnemunde, May 21, 1929.
Speed, 235.941 KPH (146.606 MPH).
- Speed for 1,000 Kilometers (Germany)—Rolf Starke, Heinkel HE-9, BMW-6 600 HP, at Warnemunde, June 10, 1929.
Speed, 222.277 KPH (138.116 MPH).
- Speed for 2,000 Kilometers (France)—Lt. de Vaisseau Paris and M. Hebert, Latécoère 28, Hispano-Suiza 600 HP, at St. Laurent de la Salanque, June 23, 1930.
Speed, 185.931 KPH (117.396 MPH).
- Speed for 5,000 Kilometers—(No Record).
- Speed for 100 Kilometers—Lt. S. W. Callaway, U. S. N., Vought Corsair, Pratt & Whitney 425 HP Wasp, at Hampton Roads, Va., April 23, 1927.
Speed, 236.998 KPH (147.263 MPH).
- Speed for 500 Kilometers—Lt. J. D. Barner, U. S. N., Vought Corsair, Pratt & Whitney Wasp 425 HP, at Hampton Roads, Va., April 30, 1927.
Speed, 218.90 KPH (136.023 MPH).
- Speed for 1,000 Kilometers—Lt. B. J. Connell and S. R. Pope, PN-10, 2 Packard 600 HP ea., at San Diego, Cal., July 8, 1927.
Speed, 142.74 KPH (88.69 MPH).
- Speed for 2,000 Kilometers—Lts. B. J. Connell and H. C. Rodd, U. S. N., PN-10, 2 Packard 600 HP ea., at San Diego, Cal., August 15-16, 1927.
Speed, 126.567 KPH (78.664 MPH).
(No Record.)

CLASS C2—WITH PAY LOAD OF 1,000 KILOGRAMS (2,204.62 Lbs.)

RETURNING TO POINT OF DEPARTURE

WORLD RECORDS

- Duration (France)—Lt. de Vaisseau Paris and M. Hebert, Latécoère 28, Hispano-Suiza 600 HP, at St. Laurent de la Salanque, June 22, 1930.
Time, 20H, 2M.
- Distance (France)—Lt. de Vaisseau Paris and M. Hebert, Latécoère 28, Hispano-Suiza 600 HP, at St. Laurent de la Salanque, June 22, 1930.
Distance, 2,854.244 Kilo. (1,773.603 Miles)
- Altitude (United States)—Boris Sergievsky, Sikorsky S-38, 2 Pratt & Whitney Hornets 575 HP ea., at Bridgeport, Conn., July 21, 1930.
Height, 8,208 Meters (26,929 Feet).

AMERICAN RECORDS

- Duration—Lts. Zeus Soucek and Lisle J. Maxson, Navy PN-12, 2 Wright R 1750 525 HP ea., at Philadelphia, Pa., May 25-26, 1928.
Time, 17H, 55M, 13.6S.
- Distance—Lt. A. W. Gorton and Chief Boatswain E. E. Reber, U. S. N., PN-12, 2 Pratt & Whitney 525 HP ea., at Philadelphia, Pa., July 11-12, 1928.
Distance, 2,150 Kilo. (1,336 Miles).
World and American Record.

SPEEDS FOR SPECIFIED DISTANCES

- Speed for 100 Kilometers (Germany)—Rolf Starke, Heinkel, BMW VI 600 HP, at Warnemunde, May 21, 1929.
Speed, 235.294 KPH (146.205 MPH).
- Speed for 500 Kilometers (Germany)—Rolf Starke, Heinkel HE-9a, BMW 600 HP, at Warnemunde, May 7, 1929.
Speed, 235.941 KPH (146.606 MPH).
- Speed for 1,000 Kilometers (France)—Lt. de Vaisseau Paris and M. Hebert, Latécoère 28, Hispano-Suiza 600 HP, at St. Laurent de la Salanque, June 23, 1930.
Speed, 190.004 KPH (118.085 MPH).
- Speed for 2,000 Kilometers (France)—Lt. de Vaisseau Paris and M. Hebert, Latécoère 28, Hispano-Suiza 600 HP, at St. Laurent de la Salanque, June 23, 1930.
Speed, 185.931 KPH (117.396 MPH).
- Speed for 5,000 Kilometers—(No Record).
- (No Record.)
- Speed for 500 Kilometers—Lt. B. J. Connell and S. R. Pope, PN-10, 2 Packard 600 HP ea., at San Diego, Cal., July 8, 1927.
Speed, 145.68 KPH (90.52 MPH).
- Speed for 1,000 Kilometers—Lt. B. J. Connell and S. R. Pope, PN-10, 2 Packard 600 HP ea., at San Diego, Cal., July 8, 1927.
Speed, 142.74 KPH (88.69 MPH).
- Speed for 2,000 Kilometers—Lt. A. W. Gorton and Chief Boatswain E. E. Reber, U. S. N., PN-12, 2 Pratt & Whitney 525 HP ea., at Philadelphia, Pa., July 11-12, 1928.
Speed, 130.427 KPH (81.043 MPH).
(No Record.)

CLASS C2—WITH PAY LOAD OF 2,000 KILOGRAMS (4,400.24 Lbs.)

RETURNING TO POINT OF DEPARTURE

WORLD RECORDS

AMERICAN RECORDS

Duration (United States)—Lt. A. W. Gorton and Chief Boatswain E. E. Reber, U. S. N., PN-12, 2 Pratt & Whitney 525 HP ea., at Philadelphia, Pa., July 11-12, 1928.
Time, 16H, 39M.

Distance (Closed Circuit) (France)—Lt. de Vaisseau Demougeot and M. Gonord, Latécoère 38, 2 Hispano-Suiza 650 HP ea., Cape Magnan-Cape Martin Lion de Terre course, September 2, 1931.
Distance, 2,208.420 Kilo. (1,372.246 Miles).

Altitude (United States)—Boris Sergievsky, Sikorsky S-38, 2 Type B Pratt & Whitney Hornets 575 HP ea., at North Beach, Queens, N. Y., August 11, 1930.
Height, 6,074 Meters (19,927.78 Feet).

World and American Record.

Distance (Closed Circuit)—Lt. A. W. Gorton and Chief Boatswain E. E. Reber, U. S. N., PN-12, 2 Pratt & Whitney 525 HP ea., at Philadelphia, Pa., July 11-12, 1928.
Distance, 2,150 Kilo. (1,336 Miles).

World and American Record.

SPEEDS FOR SPECIFIED DISTANCES

Speed for 100 Kilometers (France)—Prevot, Latécoère 28, Hispano-Suiza 650 HP, at St. Laurent de la Salanque, March 5, 1930.
Speed, 220.026 KPH (136.718 MPH).

Speed for 500 Kilometers (France)—Prevot, Latécoère 28 monoplane, Hispano-Suiza 650 HP, at St. Laurent de la Salanque, March 5, 1930.
Speed, 202.092 KPH (125.573 MPH).

Speed for 1,000 Kilometers (Germany)—Richard Wagner, Dornier Superwal, DR-142, 4 Gnome-Rhone-Jupiter 480 HP ea., at Frederickshaven-Lindau, February 2, 1928.
Speed, 177.279 KPH (110.155 MPH).

Speed for 2,000 Kilometers (France)—Lt. de Vaisseau Demougeot and M. Gonord, Latécoère 38, 2 Hispano-Suiza 650 HP ea., Cape Magnan-Cape Martin Lion de Terre course, September 2, 1931.
Speed, 163.628 KPH (101.674 MPH).

Speed for 5,000 Kilometers—(No Record).

(No record.)

Speed for 500 Kilometers—Lt. B. J. Connell and S. R. Pope, PN-10, 2 Packard 600 HP ea., at San Diego, Cal., July 8, 1927.
Speed, 145.68 KPH (90.52 MPH).

Speed for 1,000 Kilometers—Lt. J. B. Connell and S. R. Pope, PN-10, 2 Packard 600 HP ea., at San Diego, Cal., July 8, 1927.
Speed, 142.74 KPH (88.69 MPH).

Speed for 2,000 Kilometers—Lt. A. W. Gorton and Chief Boatswain E. E. Reber, U. S. N., PN-12, 2 Pratt & Whitney 525 HP ea., at Philadelphia, Pa., July 11-12, 1928.
Speed, 130.427 KPH (81.043 MPH).

(No Record.)

CLASS C2—WITH PAY LOAD OF 5,000 KILOGRAMS (11,023 Lbs.)

RETURNING TO POINT OF DEPARTURE

WORLD RECORDS

AMERICAN RECORDS

Duration (Closed Circuit) (France)—M. Gonord, Latécoère 38, 2 Hispano-Suiza 650 HP ea., Arcachon-Cape Ferret-Hourtin (Les Genets)-Contis-les-Bains course, September 30, 1931.
Time, 4H, 3M.

Distance (Closed Circuit) (France)—M. Gonord, Latécoère 38, 2 Hispano-Suiza 650 HP ea., Arcachon-Cape Ferret-Hourtin (Les Genets)-Contis-les-Bains course, September 30, 1931.
Distance, 514.220 Kilo. (319.521 Miles).

Altitude (Germany)—Steindorff, Rohrbach Romar, 2 BMW 500 HP ea., at Trarvmunde, April 17, 1929.
Height, 2,000 Meters (6,562 Feet).

Speed for 100 Kilometers (France)—M. Gonord, Latécoère 38, 2 Hispano-Suiza 650 HP ea., Arcachon-Cape Ferret-Hourtin (Les Genets)-Contis-les-Bains course, September 30, 1931.
Speed, 114.979 KPH (71.444 MPH).

Speed for 500 Kilometers (France)—M. Gonord, Latécoère 38, 2 Hispano-Suiza 650 HP ea., Arcachon-Cape Ferret-Hourtin (Les Genets)-Contis-les-Bains course, September 30, 1931.
Speed, 140.621 KPH (87.378 MPH).

Speed for 1,000 Kilometers—(No Record).

Speed for 2,000 Kilometers—(No Record).

Speed for 5,000 Kilometers—(No Record).

(No Record.)

(No Record.)

(No Record.)

(No Record.)

(No Record.)

(No Record.)

(No Record.)

(No Record.)

CLASS C2—WITH PAY LOAD OF 10,000 KILOGRAMS (22,046 Lbs.)

RETURNING TO POINT OF DEPARTURE WITHOUT REFUELING

WORLD RECORDS

Duration—(No Record).
 Distance—(No Record).
 Altitude—(No Record).

AMERICAN RECORDS

(No Record.)
 (No Record.)
 (No Record.)

SPEEDS FOR SPECIFIED DISTANCES

Speed for 100 Kilometers—(No Record).
 Speed for 500 Kilometers—(No Record).
 Speed for 1,000 Kilometers—(No Record).
 Speed for 2,000 Kilometers—(No Record).
 Speed for 5,000 Kilometers—(No Record).

(No Record.)
 (No Record.)
 (No Record.)
 (No Record.)
 (No Record.)

CLASS C2—GREATEST PAY LOAD CARRIED TO AN ALTITUDE OF 2,000 METERS (6,651.7 Feet)**WORLD RECORDS**

(Germany)—Steindorff, Rohrbach Romar,
 3 BMW 500 HP ea., at Travemunde,
 April 17, 1929.
 Weight, 6,450 Kgs. (14,220 Lbs.).

AMERICAN RECORDS

Lts. B. J. Connell and H. C. Rodd, U. S. N.
 PN-10, 2 Packard 660 HP ea., at San Diego
 Cal., August 18, 1927.
 Weight, 3,504 Kgs. (7,726 Lbs.).

FEMININE RECORDS

Altitude (United States)—Mrs. Marion Eddy
 Conrad, Savoia-Marchetti, Kinner 125 HP,
 at Port Washington, L. I., N. Y., October
 20, 1930.
 Height, 4,103 Meters (13,461.259 Feet).

World and American Record.

CLASS C2—LIGHT SEAPLANES—FIRST CATEGORY

Two seaters weight empty less than 500 Kgs. (1,102 Lbs.)

WORLD RECORDS

Duration (Roumania)—Capt. Pantazi and
 G. Grozea, Icar Messerschmitt 23 b w,
 Siemens, 92 HP, at Constanza Siud Ghiol,
 October 2, 1932.
 Time, 12H, 2M.
 Distance (Closed Circuit) (France)—Lallouette
 and Boulanger, Farman, Renault 95
 HP, Le Pecq-Mantes course, April 24, 1931.
 Distance, 1,492.190 Kilo. (927.202 Miles).
 Distance (Airline) (France)—Lallouette and
 Albert, Farman, 231, Renault 95 HP,
 Le Pecq to Caudebec-en-Caux, May 13,
 1931.
 Distance, 122.560 Kilo. (76.155 Miles).
 Altitude (Italy)—Domenico Antonini, pilot;
 Spartaco Trevisan, passenger; Caproni Ca
 100 Idro, Cirrus Hermes 105 HP, at Lam-
 brate Airport, Milan, February 27, 1931.
 Height, 5,324 Meters (17,467.156 Feet).
 Speed for 100 Kilometers (France)—Lallouette
 and Boulanger, Farman, Renault 95
 HP, Draveil-Montereau course, March 28,
 1931.
 Speed, 189.433 KPH (117.708 MPH).

AMERICAN RECORDS

(No Record.)
 (No Record.)
 (No Record.)
 (No Record.)
 (No Record.)
 (No Record.)

CLASS C2—LIGHT SEAPLANES—SECOND CATEGORY

Two seaters weight empty less than 350 Kgs. (771 Lbs.)

WORLD RECORDS	AMERICAN RECORDS
Duration (France)—De Viscaya and Chaudet, Farman 230, Salmson 40 HP, Le Pecq-Bonnières-Le Rhoulé, June 26, 1931. Time, 11H, 31M, 32S.	(No Record.)
Distance (Closed Circuit) (France)—De Viscaya and Chaudet, Farman 230, Salmson 40 HP, Le Pecq-Bonnières-Le Rhoulé, June 26, 1931. Distance, 1,184.256 Kilo. (735.861 Miles).	(No Record.)
Distance (Airline)—(No Record.)	(No Record.)
Altitude (France)—Jean de Viscaya and Forestier, Farman F-231, Salmson 40 HP, Farman-Le Pecq course, June 11, 1931. Height, 3,231 Meters (10,600.361 Feet).	(No Record.)
Speed for 100 Kilometers (France)—De Viscaya and Chaudet, Farman 230, Salmson 40 HP, Le Pecq-Bonnières-Le Rhoulé, June 26, 1931. Speed, 143.540 KPH (89.191 MPH).	(No Record.)

CLASS C2—LIGHT SEAPLANES—THIRD CATEGORY

Single seater weight empty between 250-437.5 Kgs. (551-965 Lbs.)

WORLD RECORDS	AMERICAN RECORDS
Duration (France)—Jean de Viscaya, Farman 230, Salmson 40 HP, Bonnières-Le Rhoulé and Pont de St. Germain-Pont de Sartrouville courses, September 28, 1931. Time, 18H, 39M.	(No Record.)
Distance (Closed Circuit) (France)—Jean de Viscaya, Farman 230, Salmson 40 HP, Bonnières-Le Rhoulé and Pont de St. Germain-Pont de Sartrouville courses, September 28, 1931. Distance, 2,210.740 Kilo (1,373.687 Miles).	(No Record.)
Distance (Airline)—(No Record.)	(No Record.)
Altitude (Germany)—Wilhelm Zimmerman, Junkers J 50-W, Armstrong Siddeley Genet 85 HP, at Dessau, June 4, 1930. Height, 5,652 Meters (18,543.270 Feet).	(No Record.)
Speed for 100 Kilometers (Germany)—Alfred Grundke, Junkers J 50-W, Armstrong Siddeley Genet 85 HP, at Dessau, June 13, 1930. Speed, 165.044 Kilo (102.554 Miles).	(No Record.)

CLASS C2—LIGHT SEAPLANES—FOURTH CATEGORY

Single seater weight empty less than 250 Kgs. (551 Lbs.)

WORLD RECORDS	AMERICAN RECORDS
Duration—(No Record.)	(No Record.)
Distance (Closed Circuit) (France)—Vercruysse, Peyret-Mauboussin, A. B. C. Scorpion 34 HP, Chatou-Epinay course, December 22, 1930. Distance, 550 Kilo. (341.753 Miles).	(No Record.)
Distance (Airline)—(No Record.)	(No Record.)
Altitude (France)—Vercruysse, Peyret-Mauboussin, A. B. C. Scorpion 34 HP, at Argenteuil, December 10, 1930. Height, 3,461 Meters (11,354.064 Feet).	(No Record.)
Speed for 100 Kilometers (France)—Vercruysse, Peyret-Mauboussin, A. B. C. Scorpion 34 HP, Chatou-Epinay course, December 24, 1930. Speed, 122.783 KPH (76.293 MPH).	(No Record.)

CLASS A—BALLOONS

FIRST CATEGORY (600 CUBIC METERS)

WORLD RECORDS

AMERICAN RECORDS

- Duration (France)—G. Cormier, August 10-11, 1924.
Time, 22H, 34M.
Distance (France)—Georges Cormier, July 1, 1922.
Distance, 804.173 Kilo. (499.69 Miles).
Altitude—(No Record).

(No Record.)

(No Record.)

(No Record.)

SECOND CATEGORY (601-900 CUBIC METERS)

- Duration (France)—Jules Dubois, May 14-15, 1922.
Time, 23H, 28M.
Distance (France)—Georges Cormier, July 1, 1922.
Distance, 804.173 Kilo. (499.69 Miles).
Altitude—(No Record).

Duration—W. C. Naylor and K. W. Warren, "Skylark," Little Rock, Ark., to Crawford, Tenn., April 29-30, 1926.
Time, 19H.

Distance—W. C. Naylor and K. W. Warren, "Skylark," Little Rock, Ark., to Crawford, Tenn., April 29-30, 1926.
Distance, 660 Kilo. (410 Miles).
(No Record.)

THIRD CATEGORY (901-1,200 CUBIC METERS)

- Duration (United States)—E. J. Hill and A. G. Schlosser, Ford Airport to Montvale, Va., July 4-5, 1927.
Time, 26H, 46M.
Distance (France)—Jean Herbe, St. Cloud-Neuewise, Silesia, course, September 10, 1932.
Distance, 999 Kilo. (620.749 Miles).
Altitude—(No Record).

World and American Record.

Distance—S. A. U. Rasmussen, Ford Airport to Hookerton, N. C., July 4-5, 1927.
Distance, 920.348 Kilo. (571 Miles).

(No Record.)

FOURTH CATEGORY (1,201-1,600 CUBIC METERS)

- Duration (United States)—E. J. Hill and A. G. Schlosser, Ford Airport to Montvale, Va., July 4-5, 1927.
Time, 26H, 46M.
Distance (France)—Jean Herbe, St. Cloud-Neuewise, Silesia, course, September 10, 1932.
Distance, 999 Kilo. (620.749 Miles).
Altitude—(No Record).

World and American Record.

Distance—S. A. U. Rasmussen, Ford Airport to Hookerton, N. C., July 4-5, 1927.
Distance, 920.348 Kilo. (571 Miles).

(No Record.)

FIFTH CATEGORY (1,601-2,200 CUBIC METERS)

- Duration (France)—Georges Blanchet and Dr. Geo. LeGallee, Gordon Bennett, Detroit to Waverly Hall, Ga., September 10-12, 1927.
Time, 49H.
Distance (United States)—Lt. T. G. W. Settle and Ensign W. Bushnell, Pitt Stadium, Pittsburgh, Pa., to Savage Harbor, Prince Edward Island, Canada, May 4-6, 1929.
Distance, 1,531.768 Kilo. (952 Miles).
Altitude—(No Record).

Duration—E. J. Hill and A. G. Schlosser, Gordon Bennett, Detroit to Baxley, Ga., September 10-12, 1927.
Time, 47H, 55M.

World and American Record.

(No Record.)

SIXTH CATEGORY (2,201-3,000 CUBIC METERS)

- Duration (France)—Georges Blanchet and Dr. Geo. LeGallee, Detroit to Waverly Hall, Ga., September 10-12, 1927.
Time, 49H.
Distance (United States)—Lt. T. G. W. Settle and Ensign W. Bushnell, Pitt Stadium, Pittsburgh, Pa., to Savage Harbor, Prince Edward Island, Canada, May 4-6, 1929.
Distance, 1,531.768 Kilo. (952 Miles).
Altitude (United States)—Capt. Hawthorne C. Gray, at Scott Field, Belleville, Ill., March 9, 1927.
Height, 8,690 Meters (28,510 Feet).

Duration—E. J. Hill and A. G. Schlosser, Gordon Bennett, Detroit to Baxley, Ga., September 10-12, 1927.
Time, 47H, 55M.

World and American Record.

World and American Record.

SEVENTH CATEGORY (3,001-4,000 CUBIC METERS)

- | | |
|--|--|
| Duration (France)—Georges Blanchet and Dr. Geo. LeGallee, Gordon Bennett, Detroit to Waverly Hall, Ga., September 10-12, 1927.
Time, 49H. | Duration—E. J. Hill and A. G. Schlosser, Gordon Bennett, Detroit to Baxley, Ga., September 10-12, 1927.
Time, 47H, 55M. |
| Distance (United States)—Lt. T. G. W. Settle and Ensign W. Bushnell, Pitt Stadium, Pittsburgh, Pa., to Savage Harbor, Prince Edward Island, Canada, May 4-6, 1929.
Distance, 1,531.768 Kilo. (952 Miles). | World and American Record. |
| Altitude (United States)—Capt. Hawthorne C. Gray, at Scott Field, Belleville, Ill., March 9, 1927.
Height, 8,690 Meters (28,510 Feet). | World and American Record. |

EIGHTH CATEGORY (4,001-5,000 CUBIC METERS)

- | | |
|---|---|
| Duration (Germany)—H. Kaulen, December 13-17, 1913.
Time, 87H. | Duration—C. B. Harmon, St. Louis to Edina Mo., October 4, 1909.
Time, 48H, 26M. |
| Distance (Germany)—Berliner, February 8-10, 1914.
Distance, 3,052.7 Kilo. (1,896.9 Miles). | Distance—A. R. Hawley, St. Louis to Lake Tschotogama, October 17-19, 1910.
Distance, 1,887.6 Kilo. (1,172.9 Miles). |
| Altitude (Switzerland)—Auguste Piccard and Max Cosyns, take-off from Dubendorf, landing near Volta-Mantua, August 18, 1932.
Height, 16,201 Meters (53,152.726 Feet). | Altitude—Capt. Hawthorne C. Gray, at Scott Field, Belleville, Ill., March 9, 1927.
Height, 8,690 Meters (28,510 Feet). |

CLASS B—AIRSHIPS

RETURNING TO POINT OF DEPARTURE

WORLD RECORDS

AMERICAN RECORDS

- | | |
|---|--|
| Duration (Germany)—Dr. Hugo Eckener, "Graf Zeppelin," 5 Maybach, Lakehurst, N. J., to Friedrichshafen, Germany, November 29-31, 1928.
Time, 71H. | Duration—Ensign Maytham, Navy A-236 at Miami, Fla., December 24-25, 1918.
Time, 40H, 26M. |
| Distance (Germany)—Dr. Hugo Eckener, "Graf Zeppelin," 5 Maybach, Lakehurst, N. J., to Friedrichshafen, Germany, November 29-31, 1928.
Distance, 6,384.5 Kilo. (3,967 Miles). | (No Record.) |
| Altitude (France)—Cohen, at Conte, June 18, 1912.
Height, 3,080 Meters (10,102 Feet). | (No Record.) |

SPEEDS FOR SPECIFIED DISTANCES

- | | |
|---|--------------|
| Speed for 100 Kilometers—(No Record.) | (No Record.) |
| Speed for 500 Kilometers—(No Record.) | (No Record.) |
| Speed for 1,000 Kilometers—(No Record.) | (No Record.) |
| Speed for 2,000 Kilometers—(No Record.) | (No Record.) |
| Speed for 5,000 Kilometers—(No Record.) | (No Record.) |

CLASS D—GLIDERS

WORLD RECORDS

AMERICAN RECORDS

- | | |
|---|----------------------------|
| Duration (Closed Circuit) (United States)—Lieut. William A. Cocke, Jr., Cocke Night-hawk glider, at Honolulu, Hawaii, December 17-18, 1931.
Time, 21H. | World and American Record. |
|---|----------------------------|

GREATEST DISTANCE OVER CLOSED COURSE

- | | |
|---|--------------|
| Distance (Germany)—Ferdinand Schulz, glider "Westpreussen," at Rossitten Field, May 3, 1927.
Distance, 455.8 Kilo. (283.22 Miles). | (No Record.) |
|---|--------------|

GREATEST DISTANCE IN A STRAIGHT LINE

Distance (Germany)—Gunter Groenhoff, Fafnir glider, Wasserkuppe-Rhon to Meitzendorf, near Madgeburg, July 25, 1931. Distance, 220.270 Kilo. (136.869 Miles).

Distance—J. K. O'Meara, Darmstadt glider, Elmira, N. Y. to Eatonville, Pa., July 18, 1932. Distance, 107.2 Kilo. (66.61 Miles).

SPEED OVER A CLOSED COURSE

Speed (Germany)—Ferdinand Schulz, glider "Westpreussen," at Rossitten Field, May 5, 1927. Speed, 54.545 KPH (33.892 MPH). (No Record.)

ALTITUDE ABOVE STARTING POINT

Altitude (Austria)—Robert Kronfeld, "Wien" Rhon-Rossiter, at Lienas, July 30, 1929. Height, 2,589 Meters (8,494 Feet).

Altitude—J. K. O'Meara, Darmstadt glider at Elmira, N. Y., July 24, 1932. Height, 1,457 Meters (4,780.169 Feet).

CLASS G—HELICOPTERS

Duration with return to starting point (Italy) —Marinello Nelli, Ascanio, Fiat A 50, at Rome, October 8, 1930. Time, 8M, 45S. (No Record.)

Distance in straight line non-stop (Italy)—Marinello Nelli, Ascanio, Fiat A 50, at Rome, October 10, 1930. Distance, 1,078.60 Meters (3,538.706 Feet). (No Record.)

Altitude above point of take-off (Italy)—Marinello Nelli, Ascanio, Fiat A 50, at Rome, October 13, 1930. Height, 18 Meters (59.055 Feet). (No Record.)

NATIONAL BALLOON RACE

Omaha, Nebraska, May 30, 1932

Official Standing of Contestants

Place	Entrant	Pilot and Aide	Place of Landing	Distance
1	U. S. Army	Lt. Wilford J. Paul Lt. John H. Bishop	12 mi. SW of Hatton, Saskatchewan	901.4 mi.
2	Goodyear Zeppelin	Roland J. Blair Frank A. Trotter	1 mi. SW of Tyvan, Saskatchewan	709.9 mi.
3	U. S. Army	Capt. W. J. Flood Lt. Haynie McCormick	Sherwood, North Dakota	595.4 mi.
4	City of Omaha	Edward J. Hill Roscoe Conklin	25 mi. E of Bismarck, North Dakota	446.6 mi.
5	Chevrolet	Tracy W. Southworth John E. Engle	3 mi. S of Jamestown, North Dakota	408.8 mi.

1932 GORDON-BENNETT BALLOON RACE

Basle, Switzerland, September 27, 1932

<i>Place</i>	<i>Balloon</i>	<i>Pilot and Aide</i>	<i>Place of Landing</i>	<i>Distance</i>	<i>Duration</i>
1	U. S. Navy	Settle Bushnell	Daugieliszki	963 mi.	41 h. 20 m.
2	Goodyear VIII	Van Orman Blair	Bagotoji	843 mi.	28 h. 45 m.
3	Petit Mousse	Ravaine Spiess	Tokary	769 mi.	19 h. 58 m.
4	Polonia	Fomaski Janusz	Siemien	734 mi.	24 h. 00 m.
5	14 de Abril	Nunez Carrasco	Sadowne	722 mi.	24 h. 53 m.
6	Gdynia	Hynek Burzynski	Bielany	677 mi.	17 h. 05 m.
7	l'Avanture	Marquant Renollaud	Potworow	649 mi.	24 h. 25 m.
8	Basel	von Baerle Dietschi	Zondlowice	632 mi.	21 h. 41 m.
9	Stadt Essen	Eimermacher Kaulen	Zelechlinek	625 mi.	18 h. 40 m.
10	Belgica	Demuyter Coeckelberg	Rozprza	600 mi.	21 h. 06 m.
11	V. de Beauclair	Huber Lochinger	Mycielin	563 mi.	14 h. 52 m.
12	Barmen	Dahl Bertram	Keltsch	538 mi.	17 h. 24 m.
13	Zurich	Gerber Tilgenkamp	D'Rasselwitz	499 mi.	17 h. 01 m.
14	Lafayette	Blanchet Jaccard	Falkenberg	498 mi.	18 h. 55 m.
15	Deutschland	Leimkugel Schutze	Freiwaldau	474 mi.	17 h. 46 m.
16	Brandenburg	Von Etthofen Mannsbarth	Greifendorf	434 mi.	12 h. 38 m.

1932 NATIONAL AIR RACES

August 27th—September 5th
Cleveland Municipal Airport, Cleveland, O.

BENDIX TROPHY RACE—TRANSCONTINENTAL SPEED DASH—BURBANK TO CLEVELAND

Place	Pilot	Plane	Engine	Time	Cash Prize
1st.	J. H. Haizlip	Wedell-Williams	Pratt & Whitney	8:19:45.79	\$6,750.00
2nd.	J. R. Wedell	Wedell-Williams	Wasp, Jr.	8:47:31.01	3,750.00
3rd.	Roscoe Turner	Wedell-Williams	Wasp, Jr.	9:02:25.23	2,250.00
4th.	Lee Gehlbach	Gee Bee Sports	Wasp, Jr.	9:41:39.00	1,500.00
	C. K. Vance	Vance	Wasp, Sr.	did not finish	

CORD CUP RACE—TRANSCONTINENTAL HANDICAP AIR DERBY—PACIFIC WING

				Points	
1st.	Roy Hunt	Great Lakes	Cirrus	1814.75	\$2,000.00
2nd.	Eldon Cessna	Cessna	Warner	1325.94	500.00
3rd.	Art. Carnahan	Monocoach	Wright J-6	1075.15	400.00
4th.	Gladys O'Donnell	Monocoupe	Warner	499.70	300.00
5th.	J. S. McDonnell	Great Lakes	Cirrus	447.788	200.00
6th.	Lloyd O'Donnell	Waco	Wright J-6	359.50	100.00
7th.	John Hardesty	Monocoupe	Velie M-5	221.73	100.00
8th.	John B. Vickers	Fairchild	Kinner K-5	198.45	100.00
9th.	Waldo Waterman	Waterman	Kinner K-5	176.10	100.00
10th.	Wm. E. Bleakley	Curtiss-Robin	Challenger	155.15	100.00
11th.	Arthur E. Gross	Monocoupe	Lambert 90	99.37	100.00
12th.	Cecil Allen	Travelair	Gipsy	60.303	100.00
13th.	Thos. B. Mullins	Curtiss-Robin	Challenger	57.125	100.00
14th.	Kenneth Neese	Travelair	Wright J-6	52.081	100.00
15th.	Edith Foltz	Bird	Kinner	50.10	100.00
16th.	Ed. Bush	Great Lakes	Cirrus	45.426	100.00
17th.	Jim Granger	Swallow	Wright J-5	35.50	100.00
18th.	Marshall Headle	Stearman	Wright J-5	29.25	100.00
19th.	Leslie C. Miller	Nich. Beazley	Genet	26.525	100.00
20th.	Ted Brown	Waco	Menasco	19.575	100.00
21st.	Nixon Galloway	Swallow	Wright J-5	16.538	100.00
22nd.	Neil McGaffey	Bird	Kinner	13.113	100.00
23rd.	Henry C. Thompson	Stinson	Lycoming	10.989	100.00
24th.	Bob Buck	Pitcairn	Wright J-5	10.376	100.00
25th.	Fred Burlew	Curtiss-Robin	Challenger	8.051	100.00
26th.	Jos. Hager	Curtiss-Robin	OX-5	7.825	100.00
	Chas. Spencer	Fleet	Warner	6.45	
	Martie Bowman	Waco	Jacobs K-70	5.594	
	Bob Allen	Am. Eagle	Kinner	5.206	
	Marion McKeen	Waco	Cont. A-70	4.599	
	Al Lary	Fleet	Kinner-K-5	2.513	

Place	Pilot	Plane	Engine	Points	Cash Prize
.....	Harry Sham	Stearman	Wright J-5	3,238
.....	Ross Hadley	Stearman	Wright J-5	1,925
.....	Jack Hermann	Stinson	Lycoming	225
.....	Boyd Grover	Travelair	Wright J-5	731
.....	Frank Reed	Monocoupe	Lambert	70
.....	Ulrich Richter	Klemm	Argus 4-in-line	563
.....	Clema Granger	Stinson	Lycoming	350

CORD CUP RACE—ATLANTIC WING

1st	S. C. Huffman	Waco	Cont. Rad.	1199.15	\$1,000.00
2nd	Fred Dorsett	Moth	Gipsy	1041.812	500.00
3rd	Geo. C. Lennox	Travelair	Warner Sc.	1037.70	400.00
4th	Helen McCloskey	Monocoupe	Velie M-5	639.688	300.00
5th	J. B. Crane	Travelair	Wright J-6	515.85	200.00
6th	Harold Neumann	Monocoupe	Lambert 266	419.20	100.00
7th	Melville Robinson	Waco	Wright J-5	360.00	100.00
8th	Paul Sturtevant	Aristocrat	Warner Sc.	256.5	100.00
9th	Douglas Davis	Travelair	Wright J-6	186.00	100.00
10th	J. A. Field	Travelair	OX-5	106.665	100.00
11th	Art Davis	Waco	Wright J-4	101.525	100.00
12th	Russell Moore	Stinson	Lycoming	78.80	100.00
13th	C. L. Clabaugh	Monocoupe	Warner 7 cy	77.338	100.00
14th	W. F. Cummings	Pitcairn	Wright J-5	35.85	100.00
15th	Dudley Reed	Stinson	Lycoming	24.295	100.00
16th	Dr. J. E. Owen	Curtiss-Robin		19.126	100.00
17th	Henry Brown	Travelair	Wright J-6	18.288	100.00
18th	Chester Fenton	Monocoupe	Lambert	17.80	100.00
19th	Harvey Hughes	Waco	Wright J-5	16.076	100.00
20th	Helen Richey	Bird	Kinner	14.238	100.00
21st	James E. Herndon	Monocoupe	Lambert	14.175	100.00
22nd	Ray Hill	Rearwin	Challenger	12.827	100.00
23rd	John P. Morris	Monocoupe	Warner	11.75	100.00
24th	E. W. Stitt	Spartan	Walters 9 cy	9.862	100.00

CINCINNATI TROPHY RACE—CLEVELAND TO CINCINNATI AND RETURN

				Total Elapsed Time	
1st	John Livingston	Monocoupe	Warner	2:17:29.59	\$900.00
2nd	S. J. Wittman	Wittman	Cirrus	2:24:16.17	500.00
3rd	Roy Liggett	Cessna	Warner	2:32:39.73	300.00
4th	Art Davis	Waco	Wright J-6	2:47:40.23	200.00
5th	John P. Morris	Monocoupe	Warner	2:55:44.45	100.00
6th	Herman Hamer	Laird	Warner	2:57:54.34	100.00
7th	Geo. L. Harte	Cessna	Wright J-6	3:14:54.61	100.00
8th	Art. Carnahan	Monocouch	Wright J-6		100.00
.....	G. H. Liebel	Stinson	Wright J-5	did not finish	

WM. B. LEEDS TROPHY RACE—ROOSEVELT FIELD TO CLEVELAND
MEN AND WOMEN PILOTS—PRIVATELY OWNED PLANES ONLY

Place	Pilot	Plane	Engine	Points	Cash Prize
1st.	F. W. Zelcer	Laird	Wright J-6	322.15	\$750.00
2nd.	Jack H. Wright	Monocoupe	Warner	274.175	500.00
3rd.	Lloyd O. Yost	Waco	Cont. 210	159.65	250.00
4th.	Bertram J. Goldsmith	Travelair	Wright J-7	152.5	100.00
5th.	Miss J. Goddard	Monocoupe	Warner Sc.	118.8	50.00
6th.	Leslie B. Cooper	Kellett Giro	Cont. 210	90.3	50.00
7th.	Marcellus A. King	Monocoupe	Warner	59.75	50.00
8th.	Clyde Pangborn	Pitcairn	Wright J-6	42.6	50.00
9th.	Wm Rausch	Gee Bee	Menasco	24.85	50.00
10th.	Carl Dixon	Standard (New)	Kinner K-5	22.55	50.00
11th.	A. S. Fell, Jr.	Travelair	Wright E240	17.05	50.00
12th.	Ed. A. Voras	Waco	Warner 110	7.2	50.00
	Roland Newman	Aero Marine Kl	LeBlond	7.05	
	Cecil H. Coffrin	Waco	Wright J-6-5	6.325	
	Mrs. Blanche Noyes	Travelair	Wright J-5	4.125	
	Victor Pixey	Eaglerock	Wright J-6	2.36	

SOHIO MYSTERY DERBY—DIVISION NO. 1—EVENT NO. 21

Place	Pilot	Plane	Engine	Finish Time at Akron	Cash Prize
1st.	Art Chester	Davis	LeBlond	2:34	\$235.00
2nd.	Roy O. Hunt	Great Lakes	Cirrus	2:35	141.00
3rd.	Lee Sherrick	Travelair	Ox-5	3:01	94.00
4th.	J. S. McDonnell	Great Lakes	Cirrus	3:03	20.00
5th.	Ethyl Northard	Great Lakes	Cirrus	3:10	20.00
6th.	W. P. Jones	Great Lakes	Cirrus	4:01	20.00
7th.	Wm. F. Sauters	Bird	Kinner	4:51	20.00
8th.	Helen McCloskey	Pitcairn	Wright J-6	4:57	20.00

SOHIO MYSTERY DERBY—DIVISION NO. 2—EVENT NO. 21

				Finish Time at Lorain	
1st.	Douglas Davis	Travelair	Wright J-6-7	3:03	\$312.50
2nd.	A. S. Fell, Jr.	Travelair	Wright E240	3:21	187.50
3rd.	Art. Carnahan	Monocoach	Wright J-6-7	3:30	125.00
4th.	E. A. Johnson	Travelair	Wright J-5	3:40	25.00
5th.	Gordon Mougey	Monocoupe	Warner 110	3:41	25.00
6th.	J. Goddard	Monocoupe	Warner Sc.	3:42	25.00
7th.	Wm. Rausch	Gee Bee	Menasco	3:56	25.00
8th.	L. M. Schmidlapp	Waco	Cont. R-670	3:57	25.00
9th.	Donald A. Griggs	Waco	Cont. A-70	4:10	25.00

EVENT NO. 1—FREE-FOR-ALL—115 CU. IN. MEN AND WOMEN PILOTS—6 LAPS 3½ MILE COURSE

Place	Pilot	Plane	Engine	Elapsed Time	MPH	Cash Prize
1st.	Art Davis	Heath	Cont.	14:09.79	88.963	\$270.00
2nd.	Harold Neumann	Loose Sp.	Lambert	14:10.75	87.932	150.00
3rd.	Duke Muller	Heath B. B.	Cont.	18:21.48	68.572	90.00
	L. A. Sibley	Neumann Spec.	Neumann Sp.	out in first lap		
	George McCarthy	Church M. W.	Church Mar.	out in third lap		

EVENT NO. 2—FREE-FOR-ALL—200 CU. IN. MEN AND WOMEN PILOTS—6 LAPS 3½ MILE COURSE

1st.	Art Davis	Heath	Cont.	12:24.66	101.522	\$315.00
2nd.	Harold Neumann	Loose Spec.	Lambert	13:34.32	92.838	175.00
3rd.	George McCarthy	Church M. W.	Church Mar.	13:50.76	91.001	105.00
4th.	L. A. Sibley	Neumann Spec.	Neumann Sp.	10:51.33	74.753	70.00
	Duke Muller	Heath B. B.	Cont.	out in first lap		

EVENT NO. 3—FREE-FOR-ALL—350 CU. IN. MEN AND WOMEN PILOTS—6 LAPS 3½ MILE COURSE

1st.	S. J. Wittman	Wittman Sp.	Cirrus	9:31.66	132.246	\$360.00
2nd.	Ben. O. Howard	Howard	Gipsy	9:53.65	127.347	200.00
3rd.	Roger Don Rae	Heath Spec.	Martin	11:41.79	107.724	120.00
4th.	Harold Neumann	Monocoupe	Lambert	12:30.50	100.732	80.00
5th.	Russ Van Wald	Kadiak Sport	Velic	14:38.08	86.090	40.00

EVENT NO. 4—FREE-FOR-ALL—510 CU. IN. MEN AND WOMEN PILOTS—6 LAPS 5 MILE COURSE

Place	Pilot	Plane	Engine	El. Time	MPH	Cash Prize
1st.	Ben. O. Howard	Howard	Menasco	10:20.11	171.671	\$405.00
2nd.	Roy Liggett	Cessna	Warner	10:35.66	169.902	225.00
3rd.	John Livingston	Monocoupe	Warner	10:35.91	169.835	135.00
4th.	Wm. Ong	Howard	Menasco	10:49.71	166.228	90.00
5th.	Bob Clampett	Keith Ryder	Menasco	11:15.93	159.779	45.00
	S. J. Wittman	Wittman	Cirrus	11:33.80	155.664	
	Walter Carr	Carr Spec.	OX-5	did not finish		

EVENT NO. 5—FREE-FOR-ALL—685 CU. IN. MEN AND WOMEN PILOTS—10 LAPS 5 MILE COURSE

1st.	Ben. O. Howard	Howard	Menasco	17:05.96	175.445	\$450.00
2nd.	Wm. Ong	Howard	Menasco	17:22.39	172.680	250.00
3rd.	John Livingston	Monocoupe	Warner	17:31.51	171.182	150.00
4th.	S. J. Wittman	Wittman	Cirrus	18:32.49	161.799	100.00
	Ray Moore	Keith Ryder	Menasco	Out in 7th lap		

EVENT NO. 6—FRANK B. PHILLIPS TROPHY RACE—FREE-FOR-ALL—800 CU. IN. 16 LAPS 5 MILE COURSE

1st.	Ray Moore.	Keith Ryder.	Menasco.	25:20.50.	182.220.	\$1,125.00
2nd.	Ben. O. Howard.	Howard.	Menasco.	27:01.30.	177.635.	625.00
3rd.	Roy Liggett.	Cessna.	Warner.	27:11.55.	176.519.	375.00
4th.	John Livingston.	Monocoupe.	Warner.	27:41.82.	173.303.	250.00
5th.	Wm. Ong.	Howard.	Menasco.	28:33.28.	168.098.	125.00
	Bob Clappett.	Keith Ryder.	Menasco.	29:19.90.	163.645.	
	S. J. Wittman.	Wittman.	Cirrus.	30:21.38.	158.121.	
	Lewis Bowen.	Israel.	Menasco.		Out in second lap	

EVENT NO. 7—FREE-FOR-ALL—1000 CU. IN. MEN AND WOMEN PILOTS—10 LAPS 5 MILE COURSE

Place	Pilot	Plane	Engine	El. Time	MPH	Cash Prize
1st.	James Haizlip.	Wedell-Williams.	Wasp Jr.	14:44.93.	203.405.	\$787.50
2nd.	James Wedell.	Wedell-Williams.	Wasp Jr.	14:47.83.	202.741.	437.50
3rd.	Lee Gehlbach.	Gee Bee Sp.	Wasp Jr.	16:19.69.	183.731.	262.50
4th.	Ray Moore.	Keith Ryder.	Menasco.	16:44.46.	179.200.	175.00
5th.	Wm. Ong.	Howard.	Menasco.	18:14.25.	164.496.	87.50

EVENT NO. 8—C. OR N.C. PLANES—510 CU. IN. HANDICAP—MEN AND WOMEN PILOTS—4 LAPS 3½ MILE COURSE

				Finished Time		
1st.	R. C. Havens.	Taylor Cub.	Cont.	13:39.61.		\$180.00
2nd.	Florence Klingensmith.	Waco.	Kinner B-5.	13:48.50.		100.00
3rd.	Jack Morris.	Monocoupe.	Warner.	13:50.78.		60.00
4th.	Roland Newman.	Aero Klemm.	LeBlond.	14:05.77.		40.00
5th.	Helen McCloskey.	Monocoupe.	Velie.	14:07.71.		20.00
	Paul A. Sturtevant.	Aristocrat.	Warner Sc.	14:09.71.		
	Russell Krupp.	Monocoupe.	Lambert.	14:18.56.		
	E. F. Gallagher.	Heath Par.	Cont. 4.	14:29.03.		
	Art Davis.	Buhl Pup.	Szekely.		out in first lap	

EVENT NO. 9—C. OR N.C. PLANES—110 M.P.H. BASIS—MEN AND WOMEN PILOTS—6 LAPS 3½ MILE COURSE

Place	Pilot	Plane	Engine	El. Time	Aver. Speed	Cash Prize
1st.	Roy O. Hunt.	Great Lakes.	Cirrus.	12:53.64.	97.846.	\$225.00
2nd.	Harold Neumann.	Travelair.	OX-5.	13:44.37.	91.706.	125.00
3rd.	Edwin Voras.	Waco.	Warner.	13:45.44.	91.587.	75.00
4th.	J. S. McDonnell.	Great Lakes.	Cirrus.	13:58.20.	90.193.	50.00
5th.	Carl A. Dixon.	New Standard.	Kinner K-5.	14:55.58.	84.414.	25.00

EVENT NO. 10—C. OR N.C. PLANES—125 M.P.H. BASIS—MEN AND WOMEN PILOTS—6 LAPS 3½ MILE COURSE

1st.	Eldon Cessna.	Cessna.	Warner.	10:58.52.	114.802.	\$270.00
2nd.	James Herndon.	Monocoupe.	Lambert.	11:34.38.	108.874.	150.00
3rd.	Art Chester.	Davis.	Warner.	11:43.33.	107.488.	90.00
4th.	S. W. Garrigus.	Waco.	Cont.	12:15.72.	102.756.	60.00

Place	Pilot	Plane	Engine	El. Time	Aver. Speed	Cash Prize
5th	Joe Meehan	Great Lakes	Cirrus	12:30.44	100.740	\$30.00
	Russell Krupp	Monocoupe	Lambert	12:39.93	99.482	
	Clarence McArthur	Stinson	Lycoming	13:36.70	92.507	
	Annette Gipson	Aristocrat	Warner	14:40.33	85.876	
	Roland C. Newman	Stearman	Wright J-5	cut pylon on second lap		

EVENT NO. 11.—C. OR N.C. PLANES—140 M.P.H. BASIS—MEN AND WOMEN PILOTS—6 LAPS 3½ MILE COURSE

1st	Art Davis	Waco	Wright J-6-7	10:27.48	120.481	\$270.00
2nd	Jack Morris	Monocoupe	Warner	10:54.00	115.596	150.00
3rd	Marcellus King	Monocoupe	Warner	11:08.09	113.158	90.00
4th	John H. Wright	Monocoupe	Warner	11:15.99	111.835	60.00
5th	Harold Neumann	Monocoupe	Lambert	12:23.57	101.671	30.00
	Ray Moore	Stearman	Wasp Jr.	12:33.37	100.349	
	Lloyd O'Donnell	Waco	Wright J-6	out in second lap		
	S. R. Sague	Waco	Wright J-6	out in third lap		
	Art Carnahan	Monocoupe	Wright J-6	out in third lap		

EVENT NO. 12.—C. OR N.C. PLANES—180 M.P.H. BASIS—MEN AND WOMEN PILOTS—6 LAPS 3½ MILE COURSE

1st	Douglas Davis	Travelair	Wright J-6	9:53.08	127.470	\$270.00
2nd	Art Davis	Waco	Wright J-6	10:38.50	118.402	150.00
3rd	F. W. Zelcer	Laird	Wright J-6	11:17.98	111.507	90.00
4th	Marcellus King	Monocoupe	Warner	11:28.90	109.740	60.00
5th	John H. Wright	Monocoupe	Warner	11:30.36	109.508	30.00
	Geo. L. Harte	Cessna	Wright J-6	out in second lap		

EVENT NO. 13—OX-5—OXX-6 RACE—MEN AND WOMEN PILOTS—6 LAPS 3½ MILE COURSE

1st	Harold Neumann	Travelair	OX-5	14:17.20	88.104	\$135.00
2nd	Lee Sherrick	Travelair	OX-5	14:35.08	86.392	75.00
3rd	H. M. Hughes	Travelair	OX-5	14:39.49	85.958	45.00
4th	R. A. Kling	Travelair	OX-5	15:39.88	80.435	30.00

EVENT NO. 14—DETROIT NEWS AIR TRANSPORT TROPHY RACE—CANCELLED FOR LACK OF ENTRIES

EVENT NO. 15—CHARLES THOMPSON TROPHY RACE—FREE-FOR-ALL—QUALIFYING SPEED 200 MPH 10 LAPS 5 MILE COURSE

1st	J. H. Doolittle	Gee Bee Sp.	Wasp Sr.	23:44.69	252.686	\$4,500.00
2nd	J. R. Wedell	Wedell Williams	Wasp Jr.	24:44.56	242.496	2,500.00
3rd	R. Turner	Wedell Williams	Wasp Jr.	25:44.78	233.042	1,500.00
4th	J. Haizlip	Wedell Williams	Wasp Jr.	25:50.39	231.304	1,000.00
5th	L. Gehlbach	Gee Bee	Wasp Jr.	27:00.90	222.098	500.00
	R. Hall	Springfield	Wasp Jr.	27:49.99	215.570	
	W. Ong	Howard	Menasco	31:24.09	191.073	
	Ray Moore	Keith Ryder	Menasco	out in second lap		

EVENTS NOS. 16, 17, 18—SCRATCHED FOR LACK OF ENTRIES

EVENT NO. 19—EDWARD A. STINSON MEMORIAL CUP RACE—C. OR N.C. PLANES—MEN AND WOMEN PILOTS
MODELS—S AND R—POWERED WITH LYCOMING MOTORS—6 LAPS 3½ MILE COURSE

Place	Pilot	Plane	Engine	El. Time	Aver. Speed	Cash Prize
1st	N. R. McCray	Stinson	Lycoming	16:08.06		\$450.00
2nd	J. Morris	Stinson	Lycoming	16:36.91		250.00
3rd	J. Barstow	Stinson	Lycoming	16:52.08		150.00
4th	R. Hosler	Stinson	Lycoming	17:24.20		100.00
5th	R. Moore	Stinson	Lycoming	17:33.60		50.00
	C. McArthur	Stinson	Lycoming	18:30.49		

EVENT NO. 20—GREAT LAKES TROPHY RACE—C. OR N.C. PLANES (GREAT LAKES) MEN AND WOMEN—6 LAPS
3½ MILE COURSE

1st	C. Smith	Great Lakes	Cirrus	12:19.04	102.294	\$450.00
2nd	R. O. Hunt	Great Lakes	Cirrus	12:20.76	102.057	250.00
3rd	R. G. Field	Great Lakes	Cirrus	12:46.73	98.600	150.00
4th	S. R. Sague	Great Lakes	Cirrus	12:57.42	97.244	100.00
5th	Ed. G. Busch	Great Lakes	Cirrus	12:57.79	97.198	50.00
	Neil McCray	Great Lakes	Cirrus	13:12.15	95.436	
	Cal Johnson	Great Lakes	Cirrus	14: 5.83	89.379	

EVENT NO. 21—SEE SOHIO MYSTERY DERBY—PAGE 5

EVENT NO. 22—AEROL TROPHY RACE—FREE-FOR-ALL—WOMEN PILOTS ONLY—175 M.P.H. QUALIFYING SPEED

1st	Gladys O'Donnell	Howard	Menasco	12:56.38	185.476	\$2,250.00
2nd	May Haizlip	Wedell-Williams	Wasp Jr.	13:06.34	183.126	1,250.00
3rd	Florence Klingensmith	Monocoupe	Warner	13:47.78	173.959	750.00
4th	Betty Lund	Waco	Wright J-6	23:39.20	101.465	500.00

Note:—This race was called at end of fourth lap because of rainstorm.

EVENT NO. 23—AMELIA EARHART TROPHY RACE—WOMEN PILOTS ONLY—685 CU. IN. HANDICAP—
6 LAPS 3½ MILE COURSE

Place	Pilot	Plane	Engine	El. Time	Prize
1st	Florence Klingensmith	Monocoupe	Warner	15:07.39	Essex Terraplane
2nd	Edith Foltz	Bird	Kinner	15:31.99	Trophy
3rd	Helen Richey	Bird	Kinner	15:36.78	Trophy
	Mary M. Sansome	Fleet	Warner	15:47.88	
	Helen McCloskey	Monocoupe	Velie	16:21.47	
	Mrs. Rae Trader	Trader Spec	Cont.	17:14.01	

EVENT NO. 24—PRECISION LANDING CONTEST—MEN AND WOMEN PILOTS—WITHOUT BRAKES

August 27th competition which was held on August 28th

Place	Pilot	Plane	Dist. from Mark	Cash Prize
1st	E. F. Beckley	Taylor Cub	13 ft. 2½ in.	\$45.00
2nd	Winston Kratz	Aeronca	23 ft. 2 in.	25.00
3rd	Harold Neumann	Monocoupe	35 ft. 6 in.	15.00
4th	Art Davis	Buhl Pup	50 ft.	10.00
5th	A. A. Walzak	Bird	102 ft 6 in.	5.00
	John Barstow	Stinson		
	Franklin Knapp	Avro Avian		
	Helen McCloskey	Monocoupe		
	Walter J. Carr	Carr Special		

August 28th

1st	Winston Kratz	Aeronca	5 ft 3 in.	\$45.00
2nd	Harold Neumann	Travelair	7 ft 7½ in.	25.00
3rd	A. E. Johnson	Travelair	10 ft 1 in.	15.00
4th	Art Carnahan	Monocoach	28 ft. 5 in.	10.00
5th	Roger Don Rae	Travelair	31 ft. 1 in.	5.00

August 29th

1st	Robt. Trader	Trader Spec	11 ft.	\$45.00
2nd	R. C. Havens	Taylor Cub	20 ft. 11 in.	25.00
3rd	Winston Kratz	Aeronca	26 ft 4 in.	15.00
4th	Art Chester	Davis	44 ft.	10.00
5th	A. E. Johnson	Travelair	73 ft 2 in.	5.00

August 30th

1st	Harold Neumann	Monocoupe	11 ft.	\$45.00
2nd	E. F. Beckley	Taylor Cub	20 ft. 3 in.	25.00
3rd	Art. Davis	Buhl Pup	23 ft. 6 in.	15.00
4th	Roger Don Rae	Travelair	42 ft. 6 in.	10.00
5th	Winston Kratz	Aeronca	50 ft	5.00

August 31st

1st	Roger Don Rae	Travelair	5 ft. 8½ in.	\$45.00
2nd	Art. C. Chester	Davis	13 ft. 5 in.	25.00
3rd	Robt. Trader	Trader Spec	18 ft. 6 in.	15.00
4th	Leonard Ewoldt	Travelair	23 ft. 4 in.	10.00
5th	Harold Neumann	Monocoupe	36 ft. 6 in.	5.00

September 1st

Place	Pilot	Plane	Dist. from Mark	Cash Prize
1st	Winston Kratz	Aeronca	4 ft. 3 in.	\$45.00
2nd	John Barstow	Stinson	9 ft. 5½ in.	25.00
3rd	Robt. Trader	Trader Spec.	23 ft. 4 in.	15.00
4th	Franklin Knapp	Avro Avian	27 ft. 3 in.	10.00
5th	R. C. Havens	Taylor Cub	27 ft. 4 in.	5.00

September 2nd

1st	E. A. Johnson	Travelair	2 ft. 2 in.	\$45.00
2nd	Winston Kratz	Aeronca	6 ft. 2½ in.	25.00
3rd	John Barstow	Stinson	6 ft. 4 in.	15.00
4th	Harold Neumann	Monocoupe	19 ft. 8 in.	10.00
5th	E. F. Beckley	Taylor Cub	23 ft. 2 in.	5.00

September 3rd

1st	A. E. Johnson	Travelair	1 ft. 4½ in.	\$45.00
2nd	Winston Kratz	Aeronca	2 ft. 9 in.	25.00

EVENT NO. 24—PRECISION LANDING CONTEST—MEN AND WOMEN PILOTS—WITHOUT BRAKES

3rd	John Livingston	Waco	11 ft. 8 in.	\$15.00
4th	E. F. Gallagher	Heath Parasol	13 ft.	10.00
5th	Art. Davis	Buhl Pup	18 ft 5 in.	5.00

September 4th

1st	John Livingston	Waco	2 ft 9 in.	\$45.00
2nd	Winston Kratz	Aeronca	4 ft 2 in.	25.00
3rd	R. C. Havens	Taylor Cub	17 ft. 2 in.	15.00
4th	Roger Don Rae	Travelair	17 ft. 3 in.	10.00
5th	John Barstow	Stinson	17 ft. 5 in.	5.00

September 5th

1st	John Livingston	Waco	2 ft. 6 in.	\$45.00
2nd	R. C. Havens	Taylor Cub	18 ft. 8½ in.	25.00
3rd	E. F. Beckley	Taylor Cub	20 ft. 7 in.	15.00
4th	Art. Chester	Davis	23 ft. 1½ in.	10.00
5th	Winston Kratz	Aeronca	30 ft. 5 in.	5.00

EVENT NO. 25—PARACHUTE JUMPING CONTEST

<i>Place;</i>	<i>Pilot</i>	<i>Dist. from Mark</i>	<i>Cash Prize</i>
August 27th			
1st.....	Shirley Rauner.....	160 ft.....	\$67.50
2nd.....	Ace Potter.....	244 ft.....	37.50
3rd.....	James Hayes.....	376 ft.....	22.50
4th.....	W. C. Hartley.....	474 ft.....	15.00
5th.....	Joe Crane.....	489 ft.....	7.50
August 28th			
1st.....	Jerry Wessling.....	10 ft.....	\$67.50
2nd.....	Joe "Buddy" Batzel.....	35 ft.....	37.50
3rd.....	Roger Don Rae.....	38 ft 7 in.....	22.50
4th.....	Joe Crane.....	84 ft 3 in.....	15.00
5th.....	Ace Potter.....	127 ft.....	7.50
August 29th—held on Sept. 2nd			
1st.....	Jerry Wessling.....	54 ft. 2 in.....	\$67.50
2nd.....	Roger Don Rae.....	75 ft. 2 in.....	37.50
3rd.....	Joe "Buddy" Batzel.....	80 ft. 2 in.....	22.50
4th.....	W. C. Hartley.....	206 ft.....	15.00
5th.....	Shirley Rauner.....	235 ft. 5 in.....	7.50
August 30th			
1st.....	Joe Crane.....	27 ft.....	\$67.50
2nd.....	Roger Don Rae.....	32 ft. 7 in.....	37.50
3rd.....	Lewis S. Dryer.....	63 ft.....	22.50
4th.....	E. Verne Stewart.....	75 ft.....	15.00
5th.....	Jerry Wessling.....	116 ft.....	7.50
August 31st			
1st.....	Joe. "Buddy" Batzel.....	14 ft.....	\$67.50
2nd.....	Roger Don Rae.....	38 ft. 9 in.....	37.50
3rd.....	Joe. Crane.....	61 ft. 4 in.....	22.50
4th.....	Joe. G. Sirl.....	600 ft.....	15.00
5th.....	Jerry Wessling.....	800 ft.....	7.50
September 1st			
1st.....	Roger Don Rae.....	26 ft. 3 in.....	\$67.50
2nd.....	Jerry Wessling.....	100 ft. 4 in.....	37.50
3rd.....	Joe Crane.....	120 ft. 10 in.....	22.50
4th.....	Shirley Rauner.....	135 ft. 6 in.....	15.00
5th.....	Joe. "Buddy" Batzel.....	138 ft. 7 in.....	7.50

September 2nd

Place	Pilot	Dist. from Mark	Cash Prize
1st	Joe Crane	38 ft. 5 in.	\$67.50
2nd	Roger Don Rae	53 ft. 8 in.	37.50
3rd	W. C. Hartley	106 ft. 9 in.	22.50
4th	Joe "Buddy" Batzel	125 ft. 8 in.	15.00
5th	Lewis S. Dryer	229 ft. 6 in.	7.50

September 3rd—held on Sept. 4th

1st	Joe "Buddy" Batzel	5 ft. 6 in.	\$67.50
2nd	Joe Crane	36 ft. 5 in.	37.50
3rd	Roger Don Rae	36 ft. 8 in.	22.50
4th	Shirley Rauner	113 ft. 6 in.	15.00
5th	Clem Sohn	114 ft. 3 in.	7.50

September 4th

1st	Shirley Rauner	160 ft. 1 in.	\$67.50
2nd	Joe Crane	550 ft.	37.50
3rd	Clem Sohn	650 ft. } Tie {	18.75
3rd	Joe "Buddy" Batzel	650 ft. }	18.75
4th	Roger Don Rae	950 ft.	7.50

September 5th

1st	Joe Crane	34 ft. 2 in.	\$67.50
2nd	Shirley Rauner	41 ft. 1 in.	37.50
3rd	Jerry Wessling	46 ft. 2 in.	22.50
4th	Roger Don Rae	56 ft. 9 in.	15.00
5th	Lewis S. Dryer	98 ft.	7.50

EVENT NO. 26—AUTOGIRO HURDLE RACE

Place	Pilot	Plane	Engine	El. Time	Cash Prize
1st	C. J. Faulkner	Pitcairn	Wright	8:01.59	\$225.00
2nd	John Miller	Pitcairn	Wright	9:10.20	125.00
	W. J. Sheldon	Autogiro	Wright	did not finish	
	James Ray	Pitcairn	Kinner	did not finish	

EVENT NO. 27—AUTOGIRO FLAG RACE—CANCELLED FOR LACK OF ENTRIES

EVENT NO. 28—SHELL PETROLEUM CORPORATION SPEED DASHES—MEN ONLY FOR WORLD'S RECORD OVER THREE KILOMETER COURSE

Place	Pilot	Plane	Engine	Av. Speed		Cash
				K.P.H.	M.P.H.	
1st.	James H. Doolittle.	Gee Bee.	Wasp.	476.829	296.287	\$1,575.00
2nd.	James Wedell.	Wedell-Williams.	Wasp Jr.	445.881	277.057	875.00
3rd.	Roscoe Turner.	Wedell-Williams.	Wasp Jr.	429.172	266.674	525.00
4th.	James Haizlip.	Wedell-Williams.	Wasp Jr.	428.794	266.440	350.00
5th.	Lee Gehlbach.	Gee Bee.	Wasp Jr.	398.054	247.339	175.00
	Robert Hall.	Springfield.	Wasp.	392.225	243.717	
	Ray Moore.	Keith Ryder.	Menasco.	382.604	237.738	
	Ben O. Howard.	Howard.	Menasco.	344.168	213.855	
	L. L. Bowen.	Israel.	Menasco.	325.877	202.490	

EVENT NO. 29—SHELL PETROLEUM CORPORATION SPEED DASHES—WOMEN ONLY FOR WORLD'S RECORD OVER THREE KILOMETER COURSE

1st.	May Haizlip.	Wedell-Williams.	Wasp Jr.	411.209	255.513	\$675.00
2nd.	Florence Klingensmith.	Monocoupe.	Warner	319.635	198.611	375.00
3rd.	Betty Lund.	Waco.	Wright J-6.	289.353	179.795	225.00

EVENT A—SPORTSMAN PILOT RACE—C OR N.C. PLANES—110 M.P.H. BASIS—6 LAPS 3½ MILE COURSE

Place	Pilot	Plane	Engine	El. Time		MPH	Prize
				1st Lap	6 Laps		
1st.	Wm. A. Warrick, Jr.	Great Lakes	Cirrus.	12:21.07	102.014		Trophy
2nd.	Paul Bloom.	Travelair.	OX-5.	14:11.80	88.753		Trophy
3rd.	K. G. Olderman.	Stearman.	Cont.	14:12.58	88.672		Trophy
	R. G. Field.	Challenger.	OX-5.	15:27.17	81.538		

EVENT B—SPORTSMAN PILOT RACE—C OR N.C. PLANES—125 M.P.H. BASIS—6 LAPS 3½ MILE COURSE

1st.	S. M. Nesbitt.	Monocoupe.	Lambert.	12:23.40	101.694		Trophy
2nd.	B. F. Stegall.	Travelair.	Wright J-6.	12:28.08	101.58		Trophy
3rd.	S. B. Cleverly.	Monocoupe.	Lambert.	12:37.00	99.867		Trophy
	K. Olderman.	Stearman.		13:54.29	90.615		
	R. G. Field.	Challenger.	OX-5.	out in first lap			
	Wm. Warrick, Jr.	Davis.		collided at start of lap 2			
	Paul Bloom.	Monocoupe.		collided at start of lap 2			

EVENT C—SPORTSMAN PILOT RACE—140 M.P.H BASIS—CANCELLED FOR LACK OF ENTRIES

EVENT D—SPORTSMAN PILOT RACE—FREE-FOR-ALL—CANCELLED FOR LACK OF ENTRIES

EVENT E—SPORTSMAN PILOT RACE—PENTATHLON—CANCELLED FOR LACK OF ENTRIES

EVENT F—SPORTSMAN PILOT RACE—INTERCLUB RELAY FOR AVIATION CLUBS

Place	Pilot	Plane	Engine	El. Time	
1st.	S. M. Nesbitt	Monocoupe	Lambert	5:15.89	
2nd.	F. W. Zelcer	Monocoupe	Lambert	5:20.71	End of First Relay
1st.	S. B. Cleverly	Monocoupe	Lambert	10:40.86	
2nd.	F. J. Detmar	Monocoupe	Lambert	10:50.98	End of Second Relay
1st.	K. N. Smith	Monocoupe	Lambert	16:12.96	
2nd.	J. K. Lapham	Monocoupe	Lambert	16:31.48	End of Third Relay
1st.	M. J. McMullen	Monocoupe	Lambert	21:25.28	
2nd.	Alex DeSeversky	Monocoupe	Lambert	21:51.61	Finish

AERO CLUB OF POLAND ALTITUDE COMPETITION—RACE TO ALTITUDE OF ONE MILE AND RETURN TO AIRPORT

1st.	Art Davis	Waco	Wright J-6	3:11.85	Trophy
	J. R. Wedell	Wedell-Williams	Wasp	3:14.76	
	Alex DeSeversky	Laird	Wright J-6	3:29.99	

LIST OF TROPHIES AWARDED—1932 NATIONAL AIR RACES

Donor	Trophy	Awarded To	Event
Bendix Corporation	Vincent Bendix Trophy and Plaque	James H. Haizlip	Bendix Trophy Race
Bendix Corporation	Vincent Bendix Plaque (silver)	J. R. Wedell	Bendix Trophy Race
Bendix Corporation	Vincent Bendix Plaque (bronze)	Roscoe Turner	Bendix Trophy Race
Cord Corporation	Auburn 12 Custom Speedster and Cord Cup	Roy Hunt	Cord Cup Race
Cord Corporation	Auburn Straight 8 Custom Speedster and Cord Cup Plaque	S. C. Huffman	Cord Cup Race
Wm. B. Leeds	Wm. B. Leeds Trophy and Plaque (silver)	F. W. Zelcer	Wm. B. Leeds Trophy Race
Wm. B. Leeds	Wm. B. Leeds Silver Plaque	John Wright	Wm. B. Leeds Trophy Race
Wm. B. Leeds	Wm. B. Leeds Silver Plaque	Lloyd O. Yost	Wm. B. Leeds Trophy Race
Frank B. Phillips	Woolaroc Trophy	Ray Moore	Event No. 6 Frank Phillips Trophy Race
Charles E. Thompson	Charles E. Thompson Trophy and Plaque (gold)	James Doolittle	Event No. 15 Charles E. Thompson Trophy Race
Charles E. Thompson	Charles E. Thompson Plaque (silver)	J. R. Wedell	Event No. 15 Charles E. Thompson Trophy Race
Charles E. Thompson	Charles E. Thompson Plaque (bronze)	Roscoe Turner	Event No. 15 Charles E. Thompson Trophy Race
Stinson Aircraft Corp.	Edward A. Stinson Memorial Cup	Neil R. McCray	Event No. 19

<i>Donor</i>	<i>Trophy</i>	<i>Awarded To</i>	<i>Event</i>
Great Lakes Aircraft Co.....	Charles F. Barndt Cup.....	Charles E. Smith.....	Event No. 20
Cleveland Pneumatic Tool Co....	Aerol Trophy and Plaque (gold).....	Gladys O'Donnell.....	Event No. 22—Aerol Trophy Race
Cleveland Pneumatic Tool Co....	Aerol Plaque (silver).....	May Haizlip.....	Event No. 22—Aerol Trophy Race
Cleveland Pneumatic Tool Co....	Aerol Plaque (bronze).....	Florence Klingensmith.....	Event No. 22—Aero Trophy Race
Hudson Motor Car Company....	Essex Terraplane and George Palmer Putnam Trophy.....	Florence Klingensmith.....	Event No. 23 Amelia Earhart Trophy Race
Mrs. Jack Stearns Gray.....	Mrs. Jack Stearns Gray Trophy and copy of "UP".....	Edith Foltz.....	Event No. 23 Amelia Earhart Trophy Race
Mrs. Green.....	Silver Platter.....	Helen Richey.....	Event No. 23 Amelia Earhart Trophy Race
Mrs. Martha Morehouse-Johnson.....	Martha Morehouse-Johnson Trophy.....	Winston Kratz.....	Event No. 24—Sweepstakes Award
Shell Petroleum Corporation.....	Shell Petroleum Trophy and gold Plaque.....	James H. Doolittle.....	Event No. 28—Speed Dash for Men
Shell Petroleum Corporation.....	Shell Petroleum silver Plaque.....	James Wedell.....	Event No. 28—Speed Dash for Men
Shell Petroleum Corporation.....	Shell Petroleum bronze Plaque.....	Roscoe Turner.....	Event No. 28—Speed Dash for Men
Shell Petroleum Corporation.....	Shell Petroleum Trophy and gold Plaque.....	May Haizlip.....	Event No. 29—Speed Dash for Women
Shell Petroleum Corporation.....	Shell Petroleum silver Plaque.....	Florence Klingensmith.....	Event No. 29—Speed Dash for Women
Shell Petroleum Corporation.....	Shell Petroleum bronze Plaque.....	Betty Lund.....	Event No. 29—Speed Dash for Women
Dr. J. D. Brock.....	Dr. J. D. Brock Plaque.....	Wm. A. Warrick, Jr.....	"A" Sportsman Pilot Race
Dr. J. D. Brock.....	Dr. J. D. Brock Plaque.....	Paul S. Bloom.....	"A" Sportsman Pilot Race
Dr. J. D. Brock.....	Dr. J. D. Brock Plaque.....	K. G. Olderman.....	"A" Sportsman Pilot Race
National Air Races.....	Plaque.....	S. M. Nesbitt.....	"B" Sportsman Pilot Race
National Air Races.....	Plaque.....	B. P. Stegall.....	"B" Sportsman Pilot Race
National Air Races.....	Plaque.....	S. B. Cleverly.....	"B" Sportsman Pilot Race
The Texas Company.....	Texaco Trophy.....	(Canadian Team).....	"F" Sportsman Pilot Race
		S. M. Nesbitt	
		S. B. Cleverly	
		K. N. Smith	
		M. J. McMullen	
Aero Club of Poland.....	White Eagle Trophy.....	Arthur Davis.....	Aero Club of Poland Altitude Competition
National Aeronautic Assn.....	Lowell R. Bayles Memorial Trophy.....	James Doolittle.....	World's Speed Record
Springfield, Mass.			
Standard Oil Company of Ohio..	Standard Oil Trophy.....	Art Chester.....	Sohio Mystery Derby—Div. No. 1
Standard Oil Company of Ohio..	Standard Oil Trophy.....	Douglas Davis.....	Sohio Mystery Derby—Div. No. 2

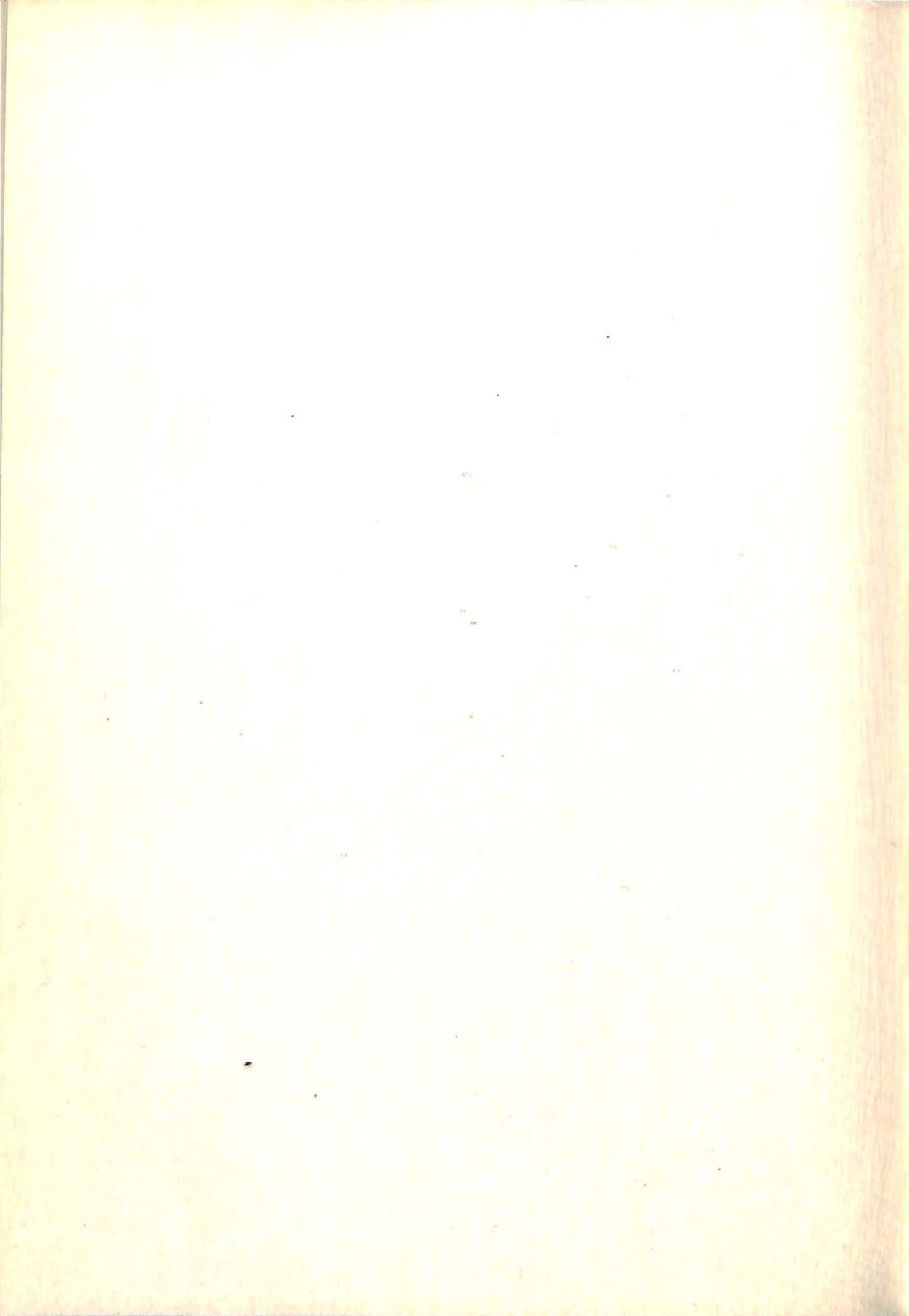

PART IV

Flying Facts and Figures

SUBJECT	PAGE
Flying in the United States.	417
Production and Sales of Aircraft in U. S.	418
Aircraft Production in U. S., 1925-32	420
Production of Engines in U. S., 1926-32	421
Production and Sales of Engines in U. S.	421
Exports of Aircraft, Engines and Parts.	422
Air Transport Operations by Months	422
Air Mail Operations by Routes in U. S.	426
Foreign Air Mail Routes and Operators	428
Army Air Corps Operations Statistics for 1932	429
Air Mail Postage Rates to Foreign Countries	430
Appropriations for Aviation in U. S., 1922-32.	431
Analysis of State Licensing Laws	432
Gasoline Taxes Affecting Aviation Analyzed	434
Aircraft Accident Statistics	435
Military Purchases and Deliveries in 1932	438
Naval Aviation Operations Statistics.	441
Army Air Corps Accident Analysis	442
Aeronautical Education in Universities.	443

FLYING IN THE UNITED STATES

Calendar Year 1932

Summary of Air Transport Operations

Year	Operators	Planes in service	Miles scheduled	Miles flown	Passengers	Passenger miles	Express (pounds)	Mail (pounds)
1926	19	95	4,608,880 (a)	5,782	6,467 (c)	433,649
1927	24	144	5,242,839 (b)	12,594	12,495 (c)	1,222,843 (d)
1928	32	294	10,472,024	52,934	35,376 (c)	3,632,059 (e)
1929	27	619	20,242,891	165,263	197,538 (c)	7,772,014 (f)
1930	35	685	30,793,119	28,833,967	385,910	94,545,784	286,798 (c)	8,513,675 (g)
1931	41	720	47,493,673	43,395,478	457,753	116,232,153	885,164 (c)	9,351,195 (h)
1932	33	655	51,932,868	48,344,358	504,575	143,169,682	1,324,428 (c)	7,658,332 (i)

- (a) Includes 2,583,056 miles flown on government operated mail routes.
 (b) Includes 1,320,535 miles flown on government operated mail routes.
 (c) Includes only express poundage carried on regular schedules and not freight flown by special order.
 (d) Includes 121,439 pounds mail flown on government operated routes.
 (e) Includes 631,541 pounds mail flown on F.A.M. routes.
 (f) Includes 675,084 pounds mail flown on F.A.M. routes.
 (g) Includes 508,474 pounds mail flown on F.A.M. routes.
 (h) Includes 346,116 pounds mail flown on F.A.M. routes.
 (i) Includes 286,162 pounds mail flown on F.A.M. routes.

Summary of Aerial Service

Year	Operators reporting	Planes in service	Miles flown	Hours flown	Passengers carried	Employees
1926	420	969	7,656,492	380,201	1,537
1927	357	768	8,341,517	476,724	1,674
1928	168	489	8,411,889	526,203	1,988
1929*	800	7,695	104,336,500	1,304,207	2,995,530	20,944
1930*	600	5,324	95,959,645	1,128,937	2,621,769	12,283
1931*	352	2,818	71,582,750	842,150	1,875,092	9,141
1932*	280	1,979	50,296,880	591,728	1,118,587	4,030

(*) Statistical estimates based on a large number of typical reports.

Summary of Private Flying

(Corporate and Personal)

	Estimated				
	1928	1929	1930	1931	1932
Miles flown.....	12,000,000	25,000,000	40,000,000	30,000,000	25,000,000
Planes in service.....	1,500	3,125	4,974	6,057	5,128

Government Flying Operations

Miles Flown

Year	U. S. Army	U. S. Navy	U. S. Coast Guard	U. S. Dept. of Commerce
1926	16,764,540	8,352,800	16,300
1927	14,871,870	10,452,720	28,990
1928	19,546,450 (a)	14,135,490 (b)	83,083	900,000
1929	27,405,790 (a)	19,513,095 (b)	48,254	1,000,000
1930	32,500,000	26,478,700 (b)	67,655	1,427,000
1931	44,000,000	28,889,835 (b)	53,440	969,000
1932	42,914,655 (a)	26,508,715 (b)	93,750	975,500

- (a) Includes National Guard.
 (b) Includes Marine Corps and Naval Reserve.

General Flying Summary

	1928*	1929	1930	1931	1932
Civilian and Commercial...	30,883,913	149,579,451	164,793,612	144,978,228	123,641,238
Government.....	34,665,023	47,967,139	60,473,355	73,912,275	70,492,620

* For 1926 and 1927 figures see "The Aircraft Year Book for 1931."

**PRODUCTION AND DELIVERIES OF SALABLE AIRCRAFT IN THE UNITED STATES
COMMERCIAL AND MILITARY**

Type	Places	Production—1931		Deliveries—1931		Production—1932		Deliveries—1932	
		Number	Value *	Number	Value *	Number	Value *	Number	Value *
Biplanes									
Open Cockpit	1	20	\$169,978.00	20	\$167,715.00	7	\$65,735.00	10	\$86,235.00
	2	172	424,303.00	183	467,573.00	74	231,707.00	141	334,047.00
	3	190	628,564.00	259	776,801.00	86	308,487.00	125	321,971.00
	Up	42	132,495.00	34	108,535.00	8	22,285.00	6	16,024.00
Sub-total		424	\$1,355,340.00	496	\$1,520,624.00	175	\$628,214.00	282	\$758,277.00
Cabin Single Engine	All	45	351,350.00	37	317,793.00	52	243,270.00	50	232,954.00
Cabin Multi-Engine	All	2	136,000.00	3	204,000.00	0	2	82,500.00
Total Biplanes		471	\$1,842,690.00	536	\$2,042,417.00	227	\$871,484.00	334	\$1,073,731.00
Monoplanes									
Open Cockpit	1	206	208,096.00	148	164,885.00	16	15,003.00	11	11,152.00
	2	496	703,482.00	417	570,752.00	110	163,024.00	120	154,342.00
	3	2	6,300.00	1	3,750.00	0	0
	Up	0	0	0	0
Sub-total		704	\$917,878.00	566	\$739,387.00	126	\$178,027.00	131	\$165,494.00
Cabin Single Engine	1	0	0	0	0
	2	33	81,435.00	35	97,810.00	50	107,000.00	46	92,548.00
	3	1	3,600.00	99	219,439.00	3	6,490.00	46	49,720.00
	4	162	437,570.00	168	445,086.00	48	136,510.00	66	144,510.00
	5	11	105,944.00	13	123,819.00	0	2	4,200.00
	6	26	252,870.00	42	385,450.00	11	144,160.00	25	178,565.00
	7	11	204,625.00	23	395,820.00	3	9,000.00	4	24,000.00
	8 and Up	10	222,880.00	11	252,130.00	20	360,159.00	23	395,862.00
Sub-total		254	\$1,308,924.00	391	\$1,919,554.00	135	\$763,319.00	212	\$880,405.00
Cabin Multi-Engine	All	63	1,342,206.00	71	1,514,082.00	8	178,152.00	8	167,749.00
Total Monoplanes		1,021	\$3,569,008.00	1,028	\$4,173,023.00	269	\$1,119,498.00	351	\$1,222,648.00
Seaplanes	All	2	15,500.00	2	12,585.00	2	19,100.00	2	19,100.00
Amphibians	All	37	819,859.00	46	1,051,716.00	12	97,307.00	27	292,456.00
Autogiros		51	408,681.00	46	377,086.00	39	230,510.00	34	199,840.00
Sub-total		90	\$1,244,040.00	94	\$1,441,387.00	53	\$346,917.00	63	\$511,396.00
Commercial Total		1,582	6,655,738.00	1,658	7,056,827.00	549	2,337,899.00	748	2,807,775.00
Military Total		812	12,971,028.00	811	13,216,761.00	593	10,389,316.00	618	10,791,343.00
Grand Total		2,394	\$19,626,766.00	2,469	\$20,873,588.00	1,142	\$12,727,215.00	1,366	\$13,599,118.00

* Values represent planes less engines.

PRODUCTION AND DELIVERIES OF COMMERCIAL AND MILITARY AIRPLANE ENGINES IN THE UNITED STATES

H. P.	1931 Production		1931 Deliveries		1932 Production		1932 Deliveries	
	Units	Value	Units	Value	Units	Value	Units	Value
Under 75.....	749	\$452,705	680	\$404,790	97	\$56,410	121	\$67,500
76-125.....	341	584,905	361	647,560	58	66,910	88	103,515
126-175.....	157	286,071	173	345,547	32	59,970	49	82,375
176-225.....	311	674,770	331	707,915	84	183,160	92	204,700
226-300.....	124	560,360	158	691,290	123	321,120	114	292,085
301-400.....	15	57,450	8	35,040	42	182,290	46	197,200
401-500.....	134	692,240	154	841,710	110	570,700	121	581,500
501-600.....	141	849,730	139	859,660	228	1,281,700	187	1,043,700
601-Up.....	4	34,000	5	42,500	30	176,111	34	206,211
Commercial Totals.....	1,976	\$4,192,231	2,009	\$4,576,012	813	\$2,898,371	852	\$2,778,876
MILITARY:								
126-175.....	31	\$82,032	31	\$82,032	0	0
176-225.....	15	29,611	30	88,131	31	\$66,450	32	\$69,050
226-300.....	29	143,840	6	28,840	59	196,550	59	196,550
301-400.....	41	163,530	41	163,530	69	282,850	68	279,100
401-500.....	869	4,461,372	877	4,525,372	114	546,800	114	546,600
501-600.....	705	4,530,333	734	4,809,636	510	2,891,968	522	2,933,591
601-Up.....	110	1,007,000	108	990,000	296	2,386,060	295	2,351,560
Military Totals.....	1,800	\$10,417,718	1,827	\$10,687,541	1,085	\$6,370,678	1,090	\$6,376,451
Grand Total.....	3,776	\$14,609,949	3,836	\$15,263,553	1,898	\$9,269,049	1,942	\$9,155,327

MONTHLY PRODUCTION AND SALES STATISTICS

Military and Salable Commercial Aircraft *

PRODUCTION

	1931				1932			
	Military		Commercial		Military		Commercial	
	Units	Value	Units	Value	Units	Value	Units	Value
January....	86	\$976,027	59	\$248,435	75	\$1,051,297	28	\$109,001
February....	84	1,301,635	88	562,480	90	1,325,713	40	172,557
March.....	87	1,158,968	148	560,019	43	690,264	67	352,359
April.....	73	1,024,510	197	834,692	35	579,386	98	451,648
May.....	61	991,506	226	777,045	25	555,299	57	181,631
June.....	80	1,385,045	264	861,720	47	1,013,628	36	141,078
July.....	61	1,120,876	176	690,484	49	831,518	43	120,957
August.....	36	767,403	140	622,977	50	925,150	39	152,055
September..	47	791,806	113	590,228	56	1,299,900	34	128,034
October....	72	1,237,701	76	385,581	44	699,719	40	164,822
November..	58	1,043,255	50	329,066	39	706,961	38	242,758
December..	67	1,172,296	45	193,011	40	710,481	29	120,999
Total....	812	\$12,971,028	1,582	\$6,655,738	593	\$10,389,316	549	\$2,337,899

DELIVERIES

January....	86	\$976,027	55	\$229,162	75	\$1,051,297	44	\$142,999
February....	83	1,331,335	80	592,139	90	1,325,713	55	246,999
March.....	89	1,196,768	157	831,535	44	710,264	84	340,387
April.....	71	969,010	187	777,418	35	579,386	116	448,653
May.....	63	1,047,006	233	866,630	33	680,732	59	160,385
June.....	79	1,366,045	229	959,843	47	1,013,628	59	186,932
July.....	62	1,139,776	180	735,182	45	794,898	61	172,937
August.....	36	767,403	149	807,648	57	979,828	88	382,960
September..	46	766,153	149	716,206	56	1,299,900	46	179,513
October....	71	1,501,687	98	543,336	57	938,255	59	209,253
November..	58	1,043,255	70	393,921	39	706,961	43	248,243
December..	67	1,172,296	71	263,807	40	710,481	34	89,414
Total....	811	\$13,216,761	1,658	\$7,656,827	618	\$10,791,343	748	\$2,807,775

* All values represent planes less motors.

REVIEW OF ANNUAL MILITARY AND COMMERCIAL PRODUCTION IN THE UNITED STATES

AIRPLANE PRODUCTION

Annual Totals

Year	Military		Commercial	
	Units	Value	Units	Value
1925.....	447 (1)	\$5,174,025 (1)	268 (1)	\$1,499,634 (1)
1926.....	532 (1)	6,154,798 (1)	604 (1)	2,716,319 (1)
1927.....	621 (1)	7,528,383 (1)	1,565	6,976,616
1928.....	1,219 (1)	19,066,379 (1)	3,542	17,194,298
1929.....	677	10,832,544	5,357	33,624,756
1930.....	747	10,723,720	1,937	10,746,042
1931.....	812	12,971,028	1,582	6,655,738
1932.....	593	10,389,316	549	2,337,899

(1) Source: Derived from U. S. Census Reports.

AIRPLANE ENGINE PRODUCTION

Annual Totals

Year	Military		Commercial	
	Units	Value	Units	Value
1926.....	842 (1)	\$4,080,571 (2)	*	*
1927.....	1,397 (1)	6,550,533 (3)	*	*
1928.....	2,620 (2)	12,407,920 (2)	632 (2)	\$979,600 (2)
1929.....	1,861	8,600,530	5,517	17,895,300
1930.....	1,841	10,823,423	1,925	6,255,493
1931.....	1,800	10,417,718	1,976	4,148,131
1932.....	1,085	6,370,678	813	2,898,371

(1) This total does not include an indeterminate number of Liberty and OX engines that were reconditioned and put into service.

(2) Department of Commerce.

(3) Derived from U. S. Census Reports.

* Liberty and OX war surplus used.

MONTHLY PRODUCTION AND SALES STATISTICS

Military and Commercial Aircraft Engines

PRODUCTION

	1931				1932			
	Military		Commercial		Military		Commercial	
	Units	Value	Units	Value	Units	Value	Units	Value
January....	122	\$626,916	55	\$112,215	168	\$1,018,000	48	\$162,135
February...	124	608,108	148	347,145	110	631,150	66	219,610
March.....	195	1,031,220	232	396,565	94	515,850	77	241,045
April.....	150	853,971	334	600,353	133	734,880	52	112,540
May.....	195	1,190,643	321	452,776	95	575,370	39	72,940
June.....	179	1,098,429	268	585,488	91	620,262	51	114,210
July.....	145	963,268	212	479,504	66	378,685	84	230,449
August.....	118	713,080	82	219,920	43	246,844	76	279,390
September..	126	812,050	91	242,685	91	558,538	49	175,790
October....	125	752,350	85	281,675	85	427,684	83	349,920
November..	147	885,733	85	253,305	60	366,848	102	524,117
December..	168	881,950	63	214,600	49	296,567	86	416,225
Total....	1,800	\$10,417,718	1,976	\$4,192,231	1,085	\$6,370,678	813	\$2,898,371

DELIVERIES

January....	152	\$910,916	71	\$216,815	134	\$867,300	40	\$124,940
February...	144	748,819	191	538,385	126	710,250	51	118,210
March.....	172	918,408	243	533,105	112	603,100	107	376,200
April.....	169	902,503	278	488,070	120	666,480	62	115,095
May.....	195	1,190,643	299	522,404	90	541,370	42	93,110
June.....	180	1,103,429	245	461,628	100	615,962	52	122,075
July.....	135	911,268	208	475,224	75	425,285	108	288,149
August.....	122	729,290	123	274,480	45	260,444	99	329,255
September..	126	812,050	120	279,165	93	588,538	54	176,725
October....	124	738,150	89	290,685	86	434,307	68	260,995
November..	140	848,390	89	277,075	60	366,848	84	357,262
December..	168	873,705	53	218,976	49	296,567	85	416,860
Total....	1,827	\$10,687,541	2,009	\$4,576,012	1,090	\$6,376,451	852	\$2,778,876

AIRCRAFT YEAR BOOK

MONTHLY AIR TRANSPORT OPERATIONS

AMERICAN AIR LINES

	Miles Scheduled	Miles Flown	Passengers	Passenger Miles	Mail (pounds)	Express (pounds)
<i>1931</i>						
January.....	2,753,550	2,475,306	17,540	4,064,869	723,096	61,063
February.....	2,632,848	2,288,395	20,078	4,903,387	678,371	62,455
March.....	2,988,916	2,663,940	27,872	6,724,101	757,451	85,486
April.....	3,651,618	3,412,594	32,079	8,320,518	778,104	59,165
May.....	3,717,970	3,491,399	34,737	9,213,029	776,603	57,631
June.....	4,066,955	3,910,931	42,928	12,263,006	803,935	61,940
July.....	4,325,875	4,213,403	55,782	14,681,694	807,508	76,850
August.....	4,716,697	4,528,908	54,163	13,978,567	832,919	101,992
September.....	4,578,488	4,381,597	62,419	15,778,643	825,174	117,263
October.....	4,808,494	4,437,306	50,958	12,575,584	863,039	88,071
November.....	4,715,720	3,861,073	31,415	7,442,473	747,666	45,122
December.....	4,506,542	3,730,616	26,873	6,288,282	757,209	68,126
Total.....	47,463,673	43,395,478	457,753	116,232,153	9,351,195	885,164
<i>1932</i>						
January.....	4,612,388	3,733,820	23,990	6,248,262	694,867	83,903
February.....	4,004,430	3,393,657	26,396	6,887,051	660,327	105,015
March.....	4,604,819	4,137,022	36,377	9,419,479	748,920	94,708
April.....	4,368,499	4,112,278	41,949	10,691,060	704,611	131,579
May.....	4,258,179	4,158,802	47,549	11,990,212	711,848	125,498
June.....	4,187,605	4,097,637	47,573	12,417,553	719,449	127,556
July.....	4,442,625	4,376,630	53,843	15,742,187	568,488	114,999
August.....	4,506,446	4,449,816	58,732	18,315,581	590,593	120,073
September.....	4,350,589	4,236,147	54,191	16,592,884	576,109	116,651
October.....	4,377,351	4,079,396	42,727	13,379,600	588,233	110,752
November.....	4,188,083	3,847,556	36,763	11,355,367	553,372	92,898
December.....	4,031,854	3,721,597	34,485	10,129,846	541,465	100,805
Total.....	51,932,868	48,344,358	504,575	143,169,682	7,658,332	1,324,428

EXPORTS OF AIRCRAFT, ENGINES AND PARTS FROM THE
UNITED STATES IN 1932

AIRPLANES, SEAPLANES AND AMPHIBIANS

Country of Destination	Full Year 1930		Full Year 1931		Full Year 1932	
	Units	Value	Units	Value	Units	Value
Brazil.....	21	\$510,234	1	\$5,050	107	\$2,555,745
Turkey.....	26	432,459
Bolivia.....	13	254,001
Colombia.....	2	33,350	4	59,700	9	191,500
Hong Kong.....	10	71,064	5	42,600	6	189,795
Peru.....	45	794,654	9	176,816
Mexico.....	45	445,626	27	374,745	21	133,571
China.....	41	935,472	38	644,170	16	88,110
Canada.....	63	673,776	16	62,394	19	80,583
Argentina.....	20	233,871	6	51,199	8	64,960
Philippine Islands.....	1	7,500	6	26,472	2	61,657
Germany.....	1	1,600	3	55,000
Belgium.....	2	48,850
Venezuela.....	2	19,951	3	41,000
Ecuador.....	3	31,201
Honduras.....	1	15,599	5	22,100
Japan.....	14	301,687	1	20,400
Australia.....	1	25,000	1	20,000
Union of South Africa.....	2	6,097	1	4,489	3	14,470
Spain.....	1	2,790	4	32,575	2	10,800
United Kingdom.....	7	123,718	7	263,512	1	10,000
France.....	1	2,500	1	6,097
New Zealand.....	5	5,839
Palestine.....	1	4,820
Netherlands West Indies.....	2	4,600
Guatemala.....	2	4,032	4	11,400	1	4,600
Uruguay.....	1	4,245
Syria.....	1	4,000
Egypt.....	1	2,500
Chile.....	17	355,090	1	58,602

Country of Destination	Full Year 1930		Full Year 1931		Full Year 1932	
	Units	Value	Units	Value	Units	Value
Siam.....	2	42,750
Panama.....	10	73,044	4	37,000
Italy.....	1	10,800	1	21,000
Czechoslovakia.....	1	11,000
Netherlands.....	3	8,766
British India.....	1	8,500	3	7,309
Rumania.....	1	1,835
Greece.....	1	1,500
Java and Madura.....	7	140,000
Cuba.....	5	36,858
Other Netherlands East Indies.....	1	20,000
Bermuda.....	1	6,000
Denmark.....	1	4,515
Iceland.....	1	1,040
Total.....	321	\$4,819,669	140	\$1,812,827	273	\$4,539,719

AIRCRAFT ENGINES

Country of Destination	Full Year 1930		Full Year 1931		Full Year 1932	
	Units	Value	Units	Value	Units	Value
Belgium.....	5	\$20,275	1	\$3,556	41	\$357,792
Soviet Russia in Europe.....	46	185,188	45	322,400	1,840	246,459
Netherlands.....	27	121,683	31	185,192	26	119,407
Sweden.....	1	15,865	7	38,372	15	98,386
Germany.....	30	212,747	7	10,563	23	96,193
Turkey.....	1	4,753	12	72,400
Colombia.....	1	7,200	3	14,805	12	64,855
Mexico.....	24	79,298	37	151,419	61	63,500
Philippine Islands.....	1	200	36	55,003
Trinidad and Tobago.....	3	22,444	7	24,393	14	49,820
Peru.....	34	180,007	2	10,500	10	34,155
Panama.....	38	148,231	28	110,815	13	28,372
Brazil.....	4	27,122	6	20,093	4	27,234
France.....	1	4,025	1	300	4	26,441
Hong Kong.....	1	4,000	6	35,400	4	17,600
Argentina.....	5	26,030	19	81,247	3	12,027
Netherlands East Indies.....	2	10,996
Bolivia.....	1	7,650	4	10,900
Latvia.....	5	10,400
Canada.....	51	69,994	12	24,904	19	8,361
Cuba.....	7	21,153	3	10,050	5	8,052
Chile.....	14	71,900	12	81,450	1	8,000
British West Indies.....	1	5,000
United Kingdom.....	1	4,462	5	13,152	1	5,000
Dominican Republic.....	1	5,000
Honduras.....	15	59,255	1	1,107	3	4,541
Venezuela.....	1	7,232	2	4,350
China.....	11	65,090	38	100,120	5	4,195
Haiti.....	2	3,034
Salvador.....	1	1,500
Portugal.....	1	1,136
Guatemala.....	4	7,758	1	1,200	2	985
Egypt.....	1	850
Finland.....	1	7,496	10	71,008	1	300
Poland and Danzig.....	10	48,098
Italy.....	6	23,292	9	35,391
Japan.....	14	64,557	7	35,161
Java and Madura.....	14	105,961	4	23,141
Nicaragua.....	1	7,500
Newfoundland and Labrador.....	1	3,500
British Honduras.....	1	3,375
Switzerland.....	1	1,278
New Zealand.....	1	482
Australia.....	5	22,734
Rumania.....	6	19,083
West Indies.....	2	9,000
Spain.....	2	7,254
Union of South Africa.....	1	6,890
Total.....	377	\$1,635,076	318	\$1,474,785	2,175	\$1,462,244

AIRCRAFT PARTS AND ACCESSORIES (EXCEPT TIRES)

<i>Country of Destination</i>	<i>Full Year</i>	<i>Full Year</i>	<i>Full Year</i>
	<i>1930</i>	<i>1931</i>	<i>1932</i>
	<i>Value</i>	<i>Value</i>	<i>Value</i>
Japan.....	\$73,671	\$116,106	\$329,952
Brazil.....	165,443	124,500	285,204
Argentina.....	204,676	48,413	189,850
Peru.....	151,639	66,002	110,939
Philippine Islands.....	12,027	23,958	91,455
Canada.....	465,196	292,712	89,137
Turkey.....	899	72,547
Belgium.....	11,603	8,288	62,320
China.....	134,084	163,945	57,704
United Kingdom.....	20,640	60,852	41,559
Soviet Russia in Europe.....	337,987	210,697	40,343
Germany.....	48,908	15,729	40,090
Netherlands.....	40,869	71,476	38,605
Mexico.....	84,091	60,244	31,359
Cuba.....	58,182	32,751	30,053
Colombia.....	14,486	5,756	29,639
France.....	17,925	7,725	21,393
Czechoslovakia.....	2,062	3,915	16,458
Sweden.....	3,126	2,433	15,568
Panama.....	52,442	27,048	13,376
Venezuela.....	11,356	655	10,723
Spain.....	7,490	540	7,772
Netherlands East Indies.....	796	7,274
Trinidad and Tobago.....	18,618	2,019	6,892
Chile.....	265,574	74,837	6,883
Honduras.....	929	463	6,456
Bolivia.....	4,222	81	6,170
Rumania.....	341	5,215
Guatemala.....	1,558	5,756	4,317
Australia.....	20,470	10,143	4,107
Italy.....	10,876	26,416	3,696
Hong Kong.....	619	3,016	3,017
Dominican Republic.....	1,101	175	2,632
Poland and Danzig.....	7,787	5,612	2,227
Java and Madura.....	27,135	21,378	2,207
Siam.....	3,321	1,050	2,135
Finland.....	1,632	5,747	1,918
Switzerland.....	6,622	3,388	1,729
Uruguay.....	2,042	1,400
British Guiana.....	96	1,343
Surinam.....	21,286	986
Egypt.....	230	979
Portugal.....	901
Lithuania.....	25	868
Nicaragua.....	4,241	854
British West Indies.....	872	1,580	848
Haiti.....	2,678	240	777
Mozambique.....	749
Union of South Africa.....	3,879	2,797	622
Jamaica.....	494	590
British India.....	534	1,135	466
British Malaya.....	19	450
Netherlands West Indies.....	439
Denmark.....	175	175	431

FLYING FACTS AND FIGURES

425

<i>Country of Destination</i>	<i>Full Year 1930 Value</i>	<i>Full Year 1931 Value</i>	<i>Full Year 1932 Value</i>
British Oceania.....			358
French West Indies.....			265
Palestine.....			262
Canal Zone.....			240
French Guiana.....			217
New Zealand.....	472	706	193
Barbados.....		64	165
Norway.....		899	159
El Salvador.....	4,243	1,116	147
Virgin Islands of U. S.....	1,536		110
Equador.....		118	107
Costa Rica.....	1,175		74
British East Africa.....	98		62
Newfoundland and Labrador.....	294	2,868	60
Canary Islands.....			56
Greece.....			53
Algeria and Tunisia.....			34
Belgian Congo.....			30
Austria.....	610		30
Yugoslavia.....	9,731	37	17
Morocco.....	6,037		15
British Honduras.....	1,057		11
Albania.....			7
Italian Africa.....		1,730	
Kwangtung.....		1,236	
Latvia.....		140	
Bermuda.....		130	
Syria.....	430	81	
Azores and Madeira Islands.....		52	
Hungary.....	25	29	
Bulgaria.....		13	
Persia.....	1,800		
Other Portuguese Africa.....	25		
Total.....	\$2,351,651	\$1,521,828	\$1,708,296

DOMESTIC AIR MAIL OPERATIONS BY ROUTES DURING CALENDAR YEAR 1932

<i>AM Number</i>	<i>Contractor</i>	<i>Route</i>	<i>Miles of Airway Routes</i>	<i>Miles Scheduled</i>	<i>Miles Actually Flown</i>	<i>Pounds of Mail Dispatched</i>	<i>Amount Paid to Carrier</i>
1	American Airways, Inc.	Boston to New York via Providence, R. I., and Hartford, Conn.	211	294,305	254,687	110,144	\$126,284.72
2	American Airways, Inc.	Chicago to Memphis, Tenn. via Springfield, Ill. and St. Louis, Mo.	523	572,601	530,968	54,664	295,205.00
3	United Air Lines	Chicago to Dallas via Moline, Ill., Kansas City, Mo.; Wichita, Kans.; Ponca City, Tulsa, Oklahoma City, and Fort Worth.	1,048	1,867,224	1,757,259	458,160	999,216.19
4	Western Air Express	Salt Lake City to San Diego via Las Vegas, Nev. and Los Angeles.	782	754,532	742,399	75,329	378,213.20
5	United Air Lines	Salt Lake City to Seattle via Boise, Pasco, Portland and Tacoma. Also Pasco, Wash. to Spokane.	1,017	1,285,338	1,236,185	249,273	738,192.80
8	United Air Lines	Seattle to San Diego via Tacoma, Portland, Medford, San Francisco, Oakland, Fresno, Bakersfield and Los Angeles.	1,238	1,792,893	1,751,616	400,704	956,027.01
9	Northwest Airways, Inc.	Chicago to Pembina, N. D., via Rochester or Milwaukee and Twin Cities. Spur line to Duluth, Green Bay, Minn. and Mandan, N. D.	1,620	1,600,377	1,549,927	241,599	843,072.03
11	Pennsylvania Air Lines, Inc.	Cleveland to Washington via Akron, O., Pittsburgh, Pa.	326	805,546	648,557	134,660	260,853.70
12	Western Air Express	Cheyenne, Wyo. to Amarillo, Tex., via Denver and Pueblo, Colo. Also Pueblo, Colo. to Albuquerque, N. M., via Santa Fe.	764	664,908	594,039	112,737	303,595.51
17	United Air Lines	New York to Chicago, via Cleveland and Toledo, Ohio.	736	2,284,982	2,247,538	1,148,308	1,229,902.45
18	United Air Lines	Chicago to San Francisco, via Omaha, Neb., Cheyenne, Wyo., Salt Lake City and Reno. Also Omaha to Watertown, S. D.	2,286	4,456,930	4,504,285	1,080,640	3,023,209.85
19	Eastern Air Transport, Inc.†	New York to Atlanta, via Washington and Richmond, Va., Atlanta to Miami, Fla., via Jacksonville. Also Spur Lines.	2,241	3,777,901	3,490,161	816,555	1,698,799.51
20	American Airways, Inc.*	New York to Fort Worth, Tex., via Albany, Buffalo, Cleveland, Cincinnati, Memphis, Little Rock and Dallas.	1,793	2,138,981	1,764,492	252,760	963,575.25
21	American Airways, Inc.	Dallas to Galveston, Tex., via Ft. Worth, Waco and Houston.	333	250,400	237,741	32,172	116,924.64
22	American Airways, Inc.	Dallas to Brownsville, Tex., via Ft. Worth, Waco, San Antonio and Corpus Christi.	551	409,954	397,598	78,664	216,488.67

23	American Airways, Inc.	Atlanta to New Orleans, via Montgomery and Mobile, Ala.	430	319,980	300,135	82,347	138,841.42
24	American Airways, Inc.	Chicago to Cincinnati, via Indianapolis, Ind.	274	406,425	362,510	59,854	183,227.37
26	National Parks Airways, Inc.	Salt Lake City to Great Falls, Mont., via Ogden, Utah, Pocatello, Idaho, Helena and Butte, Mont.	509	745,524	727,817	50,614	348,015.87
27	Transamerican Airlines, Corp.	Bay City to Kalamazoo, Mich., via Flint and Lansing. Kalamazoo to Pontiac, via Jackson and Detroit, Chicago, Detroit, Cleveland.	1,384	1,541,816	1,385,385	150,801	595,637.55
29	American Airways, Inc.	New Orleans to Houston, Tex., via Baton Rouge, La. and Beaumont, Tex.	337	242,964	244,956	44,827	109,600.36
30	American Airways, Inc.†	Omaha to Evansville, Ind., via Kansas City and St. Louis. Chicago to Atlanta, via Evansville and Nashville.	1,028	1,351,893	1,248,125	248,280	654,051.59
30	United States Airways (Part) §	Denver to Kansas City, Mo., via Salina, Kans.	544	465,196	447,398	18,688	145,464.20
33	American Airways, Inc.	Atlanta to Los Angeles, via Birmingham, Dallas, El Paso and Phoenix. Spur Lines to Memphis, New Orleans, Amarillo.	3,357	2,942,796	2,800,578	321,525	1,782,114.16
33	Western Air Express (Part)	El Paso to Albuquerque, N. M.	222	162,726	158,220	9,298	99,955.17
34	Transcontinental & Western Air, Inc.	New York to Los Angeles, via Pittsburgh, St. Louis, Wichita, and Albuquerque. Also St. Louis to Amarillo, via Tulsa.	3,339	4,706,667	4,351,337	1,139,617	3,061,013.96
Total			26,893	35,842,859	33,733,913	7,372,220	\$19,267,482.18

* AM 16 Consolidated with AM 20 effective June 1, 1931.

† AM 25 Consolidated with AM 19 effective April 1, 1931.

‡ AM 28 Consolidated with AM 30 (Omaha-Atlanta Part) effective June 1, 1931.

§ Operations started June 1, 1931.

|| Operations started August 1, 1931.

N.B.—AM Routes 6, 7, 10, 13, 14, 15, 31 and 32 have been discontinued.

FOREIGN AIR MAIL ROUTES

U. S. Post Office Department

<i>Route No.</i>	<i>Contractor</i>	<i>One Way Distance</i>
Canadian Colonial Airways, Inc.		
F. A. M. 1	c/o American Airways, Inc., 122 East 42nd Street, New York, N. Y. New York, N. Y., via Albany, N. Y., to Montreal, Canada.	334 Miles
Seattle Victoria Air Mail, Inc.		
F. A. M. 2	56 Roanoke Street, Seattle, Wash. Seattle, Wash., to Victoria, B. C., and return.	74 Miles
John A. Hunter & Arthur O. Johnson		
F. A. M. 3	1506 Abundance, New Orleans, La. New Orleans to Pilottown, La., and return.	75 Miles
Pan American Airways, Inc.		
F. A. M. 4	122 East 42nd Street, New York, N. Y. Miami, Florida to Havana, Cuba, one way. (Cuban mail carried on return trip)	229 Miles
Pan American Airways, Inc.		
F. A. M. 5	122 East 42nd Street, New York, N. Y. <i>Long Flight:</i> Miami, Florida, via Havana, Cuba; Cozumel and Merida, Mexico; Belize, British Honduras; Puerto Barrios, Guatemala; San Salvador, El Salvador; San Lorenzo, Republic of Honduras; Managua, Nicaragua; San Jose, Costa Rica; David and Panama City, Panama; to Cristobal, Canal Zone, and return. <i>Short Flight:</i> Miami, Florida, via Cuba; Kingston, Jamaica; and Barranquilla, Colombia; to Cristobal, Canal Zone, and return.	2,251 Miles 1,667.5 Miles
Pan American Airways, Inc.		
F. A. M. 5	122 East 42nd Street, New York, N. Y. <i>Extended</i> (as of Aug. 5). Barranquilla, Colombia, via Maracaibo, La Guaira, and Caripito, Venezuela, to Port-of-Spain, Trinidad, and return.	1,021 Miles
Pan American Airways, Inc.		
F. A. M. 6	122 East 42nd Street, New York, N. Y. Miami, Florida, via Nuevitas, Cuba; Port-au-Prince, Haiti; San Pedro de Macoris, Dominican Republic; San Juan, Puerto Rico; St. Thomas, U. S. V. I.; St. Johns, Antigua; Castries, St. Lucia; Port-of-Spain, Trinidad; Georgetown, British Guiana, to Paramaribo, Dutch Guiana, and return. (as of Aug. 7). Kingston, Jamaica, via Port-au-Prince, Haiti; Santo Domingo and San Pedro de Macoris, Dominican Republic; to San Juan, Puerto Rico, and return.	2,558.5 Miles 728.5 Miles

FLYING FACTS AND FIGURES

429

Route No.	Contractor	One Way Distance
Pan American Airways, Inc.		
122 East 42nd Street, New York, N. Y.		
F. A. M. 7	Miami, Florida to Nassau, Bahama Islands. (Bahamas mail carried on return trip).....	188 Miles

Pan American Airways, Inc.		
122 East 42nd Street, New York, N. Y.		
F. A. M. 8	Brownsville, Texas, via Tampico, Mexico City, Vera Cruz, San Geronimo and Tapachula, Mexico; and Guatemala City, Guatemala; to San Salvador, El Salvador, and return	1,446.5 Miles

Pan American-Grace Airways, Inc.		
122 East 42nd Street, New York, N. Y.		
F. A. M. 9	Cristobal, Canal Zone, via Buenaventura and Tumaco, Colombia; St. Elena and Guayaquil, Ecuador; Talara, Trujillo, Lima, Arequipa and Tacna, Peru; Arica, Antofagasta, Ovalle and Santiago, Chile; Mendoza and Buenos Aires, Argentina; to Montevideo, Uruguay, and return	4,551.5 Miles

Pan American Airways, Inc.		
122 East 42nd Street, New York, N. Y.		
F. A. M. 10	Paramaribo, Dutch Guiana, via Cayenne, French Guiana; Para, Maranhao, Fortaleza, Natal, Pernambuco, Maceio, Bahia, Victoria, Rio de Janeiro, Santos, Florianopolis, Porto Alegre and Rio Grande do Sul, Brazil; Montevideo, Uruguay, to Buenos Aires, Argentina, and return	4,840.5 Miles

Pan American Airways Co.		
122 East 42nd Street, New York, N. Y.		
F. A. M. 12	(Suspended until further notice) Bangor, Maine, via St. Johns, New Brunswick to Halifax, Nova Scotia.....	281 Miles

Strength of the Army Air Corps

Dec. 31, 1932

Commissioned Officers.....	118	1,371
Student Officers.....		
Pilots.....	1,230	
Enlisted men (includes flying cadets).....		13,257
Civilians.....	3,500	

Strength of Air Corps Organized Reserves

Officers.....	5,725
Pilots and Observers.....	3,830
Number of Civilian Employees.....	3,500

POSTAGE RATES

U. S. Air Mail to Foreign Countries

RATES (postage plus fee for air-mail service) for each half ounce or fraction for air dispatch to North, Central and South America and the West Indies, are as follows:

	<i>Each Half Ounce;</i>
Argentina.....	\$.55
Bahamas.....	.10
Barbados.....	.20
Bolivia (by ordinary means from Arequipa, Peru).....	.40
*Bolivia (by Bolivian air-mail service from Tacna, Peru).....	.55
Brazil.....	.50
Canada—8 cents for first ounce; 13 cents for each additional ounce.....	.20
Canal Zone.....	.50
Chile.....	.35
Colombia.....	.20
Costa Rica.....	.10
Cuba.....	.10
Dominican Republic.....	.10
 Dutch West Indies:	
Curacao, Bonaire, Aruba.....	.30
St. Martins, St. Eustatius, Saba.....	.20
Ecuador.....	.30
Guadeloupe (including Desirade, Les Saintes, Marie Galante, Petite Terre, St. Bartholomew (Barthelemy) and the French part of St. Martins).....	.20
Guatemala.....	.15
Guianas (British, Dutch, French).....	.30
Haiti.....	.10
Honduras (British).....	.15
Honduras (Republic).....	.15
Jamaica.....	.10
 Leeward Islands:	
Anguilla, Antigua, Barbuda, Dominica, Montserrat, Nevis, Redonda, St. Christopher (St. Kitts).....	.20
British Virgin Islands.....	.10
Mexico.....	.10
Martinique.....	.20
Nicaragua.....	.15
Panama.....	.20
Paraguay (by ordinary means from Buenos Aires).....	.55
Peru.....	.40
Puerto Rico.....	.10
Salvador, El.....	.15
Trinidad.....	.20
Uruguay.....	.55
Venezuela (Maracaibo, La Guaira, Caripito).....	.30
Venezuela (including dispatch by Venezuelan air-mail service from Maracaibo or La Guaira).....	.45
Virgin Islands (U. S.).....	.10
Windward Islands (Grenada, Grenadines, St. Lucia and St. Vincent).....	.20

*Bolivian air-mail service suspended until further notice.

U. S. DOMESTIC AIR-MAIL POSTAGE RATE—8 cents for the first ounce; 13 cents for each additional ounce.

The above rates include dispatch by the United States domestic air routes, where available, as well as by the international routes. The rates to Canada, Colombia, Cuba and Mexico, provide also for dispatch by the domestic air routes of those countries, where available.

AIRCRAFT APPROPRIATIONS, UNITED STATES

1922-1934

	<i>Department Appropriations</i>	<i>Total</i>	<i>Increase or Decrease</i>	<i>Net</i>
1922-23	Army..... \$12,895,000 Navy..... 14,683,590 Air Mail..... 1,900,000 N.A.C.A..... 210,000	\$29,688,590	-\$6,305,000 +1,270,159 +650,000 +10,000	-\$4,347,841
1923-24	Army..... 12,426,000 Navy..... 14,047,174 Air Mail..... 1,500,000 N.A.C.A..... 283,000	28,856,174	-469,000 -36,416 -400,000 +73,000	-832,416
1924-25	Army..... 14,113,043.80 Navy..... 15,150,000 Air Mail..... 2,750,000 N.A.C.A..... 470,000	32,483,043.80	+1,687,043.80 +502,826 +1,250,000 +187,000	+3,626,869.80
1925-26	Army..... 14,700,000(1) Navy..... 14,790,000(2) Air Mail..... 2,810,000(3) N.A.C.A..... 534,000	32,624,000	+586,956.20 -360,000 -150,000 +64,000	+350,956.20
1926-27	Army..... 15,050,000 Navy..... 18,505,288 Air Mail..... 2,650,000(3) N.A.C.A..... 513,000	36,718,288½	+350,000 +3,715,288 -160,000 -21,000	+3,844,288
1927-28	Army..... 20,396,300 Navy..... 20,100,000 Air Mail..... 4,150,000 N.A.C.A..... 513,000 Commerce... 3,791,500	48,950,800	+5,346,300 +1,594,712 +1,500,000 +3,791,500	+12,232,512
1928-29	Army..... 24,848,562(4) Navy..... 32,189,560(5) Air Mail..... 6,430,000 N.A.C.A..... 600,000 Commerce... 4,361,850	68,429,972	+4,452,262 +12,089,560 +2,280,000 +87,000 +570,350	+19,479,172
1929-30	Army..... 34,690,785 Navy..... 31,430,000(5) Air Mail..... 13,300,000 N.A.C.A..... 1,292,200 Commerce... 6,416,620	87,129,605	+9,842,223 -759,560 +6,870,000 +692,200 +2,054,770	+18,699,633
1930-31	Army..... 35,823,473 Navy..... 32,033,211 Air Mail..... 21,600,000(6) N.A.C.A..... 1,321,000(7) Commerce... 9,207,430(8)	99,985,114	+1,132,688 +603,211 +8,300,000 +29,000 +2,790,810	+12,855,498
1931-32	Army..... 31,479,635(9) Navy..... 31,145,000 Air Mail..... 27,000,000(10) N.A.C.A..... 1,051,070(11) Commerce... 10,362,300(12)	101,038,005	-4,343,838 -888,211 +5,400,000 -269,930 +1,154,870	+1,052,891

- (1) Plus \$2,150,000 "contract authorizations" for additional purchases of aircraft.
(2) Plus \$4,100,000 "contract authorizations" for additional purchases of aircraft.
(3) For the contract Air Mail Service \$500,000 was appropriated for 1926 and \$2,000,000 was allowed for 1927.
(4) And contract authorization of \$5,000,000.
(5) And contract authorization of \$10,000,000.
(6) Includes \$6,600,000 for Foreign Air Mail.
(7) Includes \$15,000 for printing.
(8) Includes \$7,944,000 for new and improved air navigation facilities.
(9) Not less than \$15,296,231 to be spent for the purchase of new airplanes, equipment, spare parts, and accessories.
(10) Includes \$7,000,000 for Foreign Air Mail.
(11) Includes \$23,000 for printing.
(12) Includes \$9,000,000 for new and improved air navigation facilities.
+ Shows amount of increase. - Shows amount of decrease.

AIRCRAFT APPROPRIATIONS, UNITED STATES (Continued)

	<i>Department Appropriations</i>	<i>Total</i>	<i>Increase or Decrease</i>	<i>Net</i>
1932-33	Army	\$25,430,131	- \$6,040,540	
	Navy	25,245,420	- 5,809,580	
	Air Mail	26,400,000(13)	- 540,000	
	N.A.C.A.	920,000	- 131,070	
	Commerce	8,553,500(14)	- 1,808,800	- \$14,419,954
1933-34†	Army	23,818,560	- 1,620,571	
	Navy	21,624,750	- 3,620,670	
	Air Mail	27,000,000(13)	+ 540,000	
	N.A.C.A.	866,030	- 53,070	
	Commerce	7,750,780(15)	- 802,720	- 5,557,931

(13) Includes \$7,000,000 for Foreign Air Mail.

(14) Includes \$1,000,000 for "Aircraft in Commerce."

(15) Includes \$1,100,570 for "Aircraft in Commerce."

† Plus \$6,250,000 "contract authorizations" for additional purchases of aircraft.

- Shows amount of decrease. † Proposed expenditures.

STATE LAWS RELATING TO LICENSING

OF

AIRCRAFT AND AIRMEN

January 1, 1933

The following summary of the status of state licensing laws, classifying them into nine different groups so as to indicate the character of the laws in each state and the year in which the acts were passed, was prepared by the Legal and Legislative Research Service of the Aeronautical Chamber of Commerce especially for The Aircraft Year Book for 1933.

I. STATES REQUIRING FEDERAL LICENSE FOR ALL AIRCRAFT AND AIRMEN:

1. Alabama (1931) (See footnote a)
2. Arizona (1929)
3. California (1929)
4. Delaware (1929)
5. Florida (1931) (See footnotes a and b)
6. Idaho (1931) (State registration also required)
7. Illinois (1931) (See footnotes a and b)
8. Indiana (1929)
9. Iowa (1929) (See footnote c)
10. Kansas (1931)
11. Kentucky (1930, 1932) (State registration also required. See footnote d)
12. Louisiana (1932) (See footnote e)
13. Michigan (1931) (State registration also required. See footnote f)
14. Mississippi (1928)
15. Missouri (1929) (Except solo pleasure. See footnote g)
16. Montana (1929)
17. Nebraska (1929) (Does not apply to non-commercial airmen)
18. New Jersey (1931)
19. New Mexico (1929)
20. New York (1928) (Except airmen in private or pleasure flying) (h)
21. North Dakota (1930) (Covers only civil aircraft flown for hire)
22. Ohio (1931) (See footnote a)
23. Oklahoma (1931) (See footnote a)
24. Rhode Island (1929)
25. South Carolina (1930)
26. South Dakota (1929)
27. Texas (1929) (Except public aircraft of U. S. or Texas)
28. Utah (1931) (See footnote a—1st paragraph only)
29. Washington (1929)
30. Wisconsin (1929)
31. Wyoming (1931)

- II. STATES REQUIRING FEDERAL LICENSE FOR ALL COMMERCIAL AIRCRAFT AND ALL AIRMEN IN COMMERCIAL FLYING:
1. Colorado (1929) (See entry under VII, post)
 2. Dist. of Columbia (1926)
 3. Nebraska (1929) (Applies to airmen of civil aircraft, passenger carrying)
 4. Nevada (1929)
 5. North Carolina (1929)
 6. Oregon (1931) (Does not apply to airmen—see entry under III, post)
- III. STATES REQUIRING STATE OR FEDERAL LICENSE FOR ALL AIRCRAFT, AIRMEN:
1. Maine (1929) (Except public aircraft and pilots thereof)
 2. Maryland (1930)
 3. Massachusetts (1922)
 4. Minnesota (1929)
 5. New Hampshire (1929)
 6. Oregon (1929) (Does not apply to aircraft—see entry under II, supra)
 7. Tennessee (1931)
- IV. STATES REQUIRING STATE OR FEDERAL LICENSE FOR AIRCRAFT, AIRMEN IN COMMERCIAL FLYING ONLY:
- None.
- V. STATES REQUIRING STATE LICENSE FOR ALL AIRCRAFT, AIRMEN:
1. Arkansas (1927)
 2. Connecticut (1927)
 3. West Virginia (1931)
- VI. STATES REQUIRING STATE LICENSE FOR AIRCRAFT, AIRMEN IN COMMERCIAL FLYING ONLY:
- None.
- VII. STATES REQUIRING STATE LICENSE FOR AIRCRAFT, AIRMEN IN NON-COMMERCIAL FLYING:
1. Colorado (1929) (Applies to airmen and not aircraft)
- VIII. STATES REQUIRING BOTH STATE AND FEDERAL LICENSES FOR ALL AIRCRAFT AND AIRMEN:
1. Pennsylvania (1931) (Federal license prerequisite to State license)
 2. Vermont (1929)
 3. Virginia (1930)
- IX. STATES HAVING NO LICENSE REQUIREMENTS:
1. Georgia

FOOTNOTES

- (a) "Provided, however, that this restriction shall not apply to military aircraft of the United States, or of a State, Territory, or possession thereof, or to aircraft licensed by a foreign country with which the United States has a reciprocal agreement covering the operation of such licensed aircraft."
"Provided, however, that this restriction shall not apply to pilots operating aircraft of the United States, or of a State, Territory, or possession thereof."
- (b) "... or to persons operating aircraft licensed by a foreign country with which the United States has a reciprocal agreement covering the operation of licensed aircraft."
- (c) Aircraft, and pilots thereof, used exclusively in the governmental service of the United States or of any of the States are excepted, as are pilots without passengers.
- (d) Law does not apply to "public aircraft of the Federal Government, or of a State, Territory, or possession, or of a political subdivision thereof, or to aircraft licensed by a foreign country with which the United States has a reciprocal agreement covering the operation of such licensed aircraft."
- (e) Law applies to all but "public aircraft," defined to mean "an aircraft used exclusively in the governmental service of the United States." "Airmen" includes anyone who engages in the navigation of aircraft while under way and anyone who is in charge of the inspection, overhauling, or repairing of aircraft.
- (f) Law covers only airmen operating civil aircraft, and exempts from provisions military aircraft of the United States and aircraft licensed by country having reciprocal relations with United States, provided such aircraft is not engaged commercially within the State.
- (g) Law does not apply to public aircraft owned by, or to pilots in the service of, the U. S. or State of Missouri.
- (h) Law does not apply to aircraft used exclusively in the governmental service of the U. S., of the National Guard or of one or more of the civil departments of the State. Certain test flights also excepted.

AVIATION GASOLINE TAX SUMMARY

The following is a summary of gasoline tax laws as they apply to aviation in the several states. The list was prepared as of December 12, 1932, by the Legal and Legislative Research Service of the Aeronautical Chamber of Commerce.

<i>State</i>	<i>Tax</i>	<i>Dispositions of Receipts</i>	<i>Applicable to Aircraft Fuel</i>	<i>Exemption or Refund</i>
1. Alabama.....	5¢	Highways	Yes	No
2. Arizona.....	5¢	Highways	Yes	Refund
3. Arkansas.....	5¢	Highways, Airports	Yes	No
4. California.....	3¢	Highways	Yes	Refund
5. Colorado.....	4¢	Highways	Yes	Refund
6. Connecticut.....	2¢	Highways	No	Exemption
7. Delaware.....	3¢	Highways	Yes	Refund
8. Dist. of Columbia.....	2¢	Highways	Yes	Refund
9. Florida.....	6¢	Roads—Schools	Yes	No
10. Georgia.....	6¢	Roads—Schools	Yes	No
11. Idaho.....	5¢	Airfuel Tax to Aeronaut. Fund	Yes	No
12. Illinois.....	3¢	Highways	Yes	Refund
13. Indiana.....	4¢	Highways	Yes	Refund
14. Iowa.....	3¢	Highways	Yes	Refund
15. Kansas.....	3¢	Highways	Yes	Refund
16. Kentucky.....	5¢	Highways	Yes	No
17. Louisiana.....	5¢	Highways	Yes	Fed. Gov't only
18. Maine.....	4¢	Highways	Yes	$\frac{1}{2}$ of tax
19. Maryland.....	4¢	Highways	Yes	Refund
20. Massachusetts.....	3¢	Highways	Yes	Refund
21. Michigan.....	3¢	Highways—Aeronautics	Yes	No
22. Minnesota.....	3¢	Highways	Yes	Refund
23. Mississippi.....	5 $\frac{1}{2}$ ¢	Highways	Yes	All but 1¢
24. Missouri.....	2¢	Highways	Yes	Refund
25. Montana.....	5¢	Highways	Yes	Refund
26. Nebraska.....	4¢	Highways	Yes	No
27. Nevada.....	4¢	Highways	Yes	Refund
28. New Hampshire.....	4¢	Highways	Yes	Refund
29. New Jersey.....	3¢	Traffic—Waterways	Exemption
30. New Mexico.....	5¢	Highways	Yes, unless inter-state flying	Refund
31. New York.....	3¢	Highways	Yes	Refund
32. North Carolina.....	5¢	Highways	Yes	Refund
33. North Dakota.....	4¢	Highways	Yes	Refund
34. Ohio.....	4¢	Highways	Yes	Refund
35. Oklahoma.....	5¢	Highways	Yes, unless inter-state flying	No
36. Oregon.....	4¢	Highways—Aeronautics	Yes	All but 1¢
37. Pennsylvania.....	3¢	Highways—Aeronautics	Yes	No
38. Rhode Island.....	2¢	Highways	Yes	Refund
39. South Carolina.....	6¢	Highways	Yes	No
40. South Dakota.....	4¢	Highways	Yes	Refund
41. Tennessee.....	6¢	Highways, except \$50,000 to Airways	Yes	No
42. Texas.....	4¢	Highways—Schools	Yes	Refund
43. Utah.....	3 $\frac{1}{2}$ ¢	Highways	Yes, unless inter-state flying	No
44. Vermont.....	4¢	Highways	Yes	No
45. Virginia.....	5¢	Highways and Bridges	Yes	Refund
46. Washington.....	3¢	Highways	Yes	Refund and exemption
47. West Virginia.....	4¢	Highways	Yes	Refund
48. Wisconsin.....	2¢	Highways	Yes	Refund
49. Wyoming.....	4¢	Highways—Airports	Yes	No

**COMPARATIVE TABULATIONS OF ACCIDENTS—CIVIL AERONAUTICS FOR THE YEARS,
1929, 1930, 1931 AND THE FIRST SIX MONTHS OF 1932**

(Compiled by Aeronautics Branch, Department of Commerce)

Mileage Flown Per Accident

	<i>January- June, 1929*</i>	<i>July- December, 1929</i>	<i>January- June, 1930*</i>	<i>July- December, 1930</i>	<i>January- June, 1931*</i>	<i>July- December, 1931</i>	<i>January- June, 1932*</i>
Miles flown in scheduled transport operation.....	9,201,338	15,940,161	16,902,728	20,042,475	20,190,925	27,195,062	24,668,414
Miles flown in miscellaneous operations including student instruction and experimental flying.....	47,000,000	63,000,000	51,767,200	56,502,560	43,282,595	51,060,520	33,722,685
Total.....	56,201,338	78,940,161	68,669,928	76,545,035	63,473,520	78,255,582	58,391,099
Accidents, all services.....	774	949	961	1,163	1,054	1,277	914
Miles flown per accident, all services.....	72,612	83,182	71,457	65,817	60,222	61,281	63,885
Accidents, scheduled transport operations.....	61	76	44	47	61	65	67
Miles flown per accident, scheduled transport opera- tions.....	150,842	209,739	384,152	426,436	330,999	418,386	368,185
Accidents, miscellaneous operations.....	713	873	917	1,116	993	1,212	847
Miles flown per accident, miscellaneous operations.....	65,919	72,165	56,453	50,630	43,676	42,129	39,814
Fatal accidents, all services †.....	126	184	148	162	114	153	105
Miles flown per fatal accident in all services.....	446,042	429,023	463,986	472,500	556,785	511,474	556,106
Fatal accidents, scheduled transport operations †.....	8	15	6	3	5	9	11
Miles flown per fatal accident, miscellaneous opera- tions.....	1,150,167	1,062,677	2,817,121	6,680,825	4,038,185	3,021,674	2,242,583
Fatal accidents, miscellaneous operations †.....	118	109	142	159	109	144	94
Miles flown per fatal accident, miscellaneous opera- tions.....	398,305	372,781	364,558	355,362	397,088	354,587	358,752
Pilot fatalities, all services.....	86	140	119	133	95	125	82
Miles flown per pilot fatality, all services.....	653,503	563,858	577,058	575,527	668,142	626,045	712,086
Pilot fatalities, scheduled transport operations.....	8	13	5	3	5	6	10
Miles flown per pilot fatality, scheduled transport operations.....	1,150,167	1,226,166	3,380,585	6,680,825	4,038,185	4,532,510	2,466,841
Pilot fatalities, miscellaneous operations.....	78	127	114	130	90	119	72
Miles flown per pilot fatality, miscellaneous opera- tions.....	602,564	496,063	454,098	434,635	480,918	429,080	468,371

* It should be borne in mind that weather conditions during the last 6 months of the calendar year are more favorable for flying than during the first 6 months, hence, in making comparisons, figures for corresponding periods should be used in each case.

† A fatal aircraft accident is one in which 1 or more persons (passenger, pilot, or crew) were killed or fatally injured.

Causes of Accidents

Non-Scheduled Air Transport Operations

Causes	Percentages						
	January-June, 1929	July-December, 1929	January-June, 1930	July-December, 1930	January-June, 1931	July-December, 1931	January-June, 1932
Number of accidents involved....	713	873	917	1,116	991	1,212	847
PERSONNEL:							
Pilot:							
Error of judgment.....	12.80	12.15	11.17	7.17	9.23	8.04	7.19
Poor technique.....	34.66	29.78	36.85	38.75	32.98	37.95	35.85
Disobedience of orders.....	1.90	4.03	2.11	1.77	3.53	2.15	1.64
Carelessness or negligence.....	9.66	6.73	6.07	5.11	6.26	7.24	7.08
Miscellaneous.....	.58	1.87	.52	.20	.55	.27	.12
Total pilot errors.....	59.60	54.56	56.72	53.00	52.55	55.65	51.88
Other personnel:							
Supervisory.....	.18	.74	.36	0	.05	.04	0
Miscellaneous.....	1.55	2.11	.85	.33	.86	.06	.74
Total personnel errors.....	61.33	57.41	57.93	53.33	53.46	55.75	52.62
MATERIAL:							
Power Plant:							
Fuel system.....	6.51	5.67	2.88	3.87	4.20	2.87	6.27
Cooling system.....	.99	1.01	.54	.23	.84	.17	.55
Ignition system.....	2.96	1.74	1.24	1.70	1.79	2.11	2.08
Lubrication system.....	3.80	.11	.13	.43	.62	.64	.32
Engine structure.....	1.40	2.14	8.49	9.42	3.15	2.80	3.89
Propellers and accessories.....	.84	.78	.23	.07	.60	.25	.12
Engine-control system.....	.06	.45	.28	.40	.18	.58	.12
Miscellaneous.....	.28	.17	.41	.67	3.18	4.94	.79
Undetermined.....	5.09	6.93	.84	1.79	4.81	4.31	2.25
Total power-plant failures..	18.42	19.00	15.04	18.58	19.37	18.67	16.39
Structural:							
Flight-control system.....	.29	1.08	.53	.72	1.01	.58	.46
Movable surfaces.....	.14	.43	.11	.02	.25	.12	.03
Stabilizing surfaces.....	.14	.09	.22	.09	.25	.17	.25
Wings, struts, and bracings..	1.06	1.74	1.11	.85	1.65	1.07	1.26
Under carriage.....	3.06	3.71	2.83	4.38	4.06	5.22	4.69
Wheels, tires, and brakes.....	.98	1.55	1.31	2.76	1.38	1.90	2.27
Pontoons and boats.....	0	0	.05	.09	0	.17	0
Fuselage, engine mounts and fittings.....	.36	.48	.35	.18	.50	.04	.24
Tail-skid assembly.....	0	0	.16	.04	.10	.17	.27
Miscellaneous.....	.28	.49	.33	0	.30	.25	.53
Undetermined.....	0	.11	.27	.13	.23	.33	0
Total structural failures....	6.31	9.68	7.27	9.26	9.73	10.02	10.00
Handling qualities.....	2.42	2.02	1.99	1.96	2.02	2.05	2.73
Instruments.....	0	.06	0	.07	0	0	0
Total airplane failures.....	8.73	11.76	9.26	11.29	11.75	12.07	12.73
MISCELLANEOUS:							
Weather.....	3.04	2.70	5.38	3.90	3.81	3.29	7.64
Darkness.....	.37	.30	.06	.65	.25	.21	.53
Airport or terrain.....	2.28	2.04	9.63	9.01	9.96	8.21	8.64
Other.....	1.02	1.35	1.46	1.72	.75	1.28	.62
Total miscellaneous causes..	6.71	6.39	16.53	15.28	14.77	12.99	17.43
Undetermined and doubtful.....	4.81	5.44	1.24	1.52	.65	.52	.83

Injuries Classified

January to June, 1932, Inclusive

Kind of Flying	Total Persons Involved	Pilots					Co-Pilots or Students				
		Fatal	Severe	Minor	No Injury	Total	Fatal	Severe	Minor	No Injury	Total
Schedule	199	10	0	6	52	68	1	0	1	10	12
Student instruction	217	11	13	18	121	163	7	2	8	35	52
Experimental	44	4	4	6	25	39	0	0	0	0	0
Commercial	362	13	6	9	141	169	0	0	0	1	1
Pleasure	853	44	35	54	352	485	0	0	0	0	0
Total	1675	82	58	93	691	924	8	2	9	46	65

Kind of Flying	Total Persons Involved	Passengers					Aircraft Crew				
		Fatal	Severe	Minor	No Injury	Total	Fatal	Severe	Minor	No Injury	Total
Schedule	199	16	0	2	94	112	0	0	1	6	7
Student instruction	217	2	0	0	0	2	0	0	0	0	0
Experimental	44	1	0	1	3	5	0	0	0	0	0
Commercial	362	15	4	21	148	188	1	0	0	3	4
Pleasure	853	39	39	34	256	368	0	0	0	0	0
Total	1675	73	43	58	501	675	1	0	1	9	11

AERONAUTICAL PURCHASES BY MILITARY SERVICES IN 1932

The following is a compilation of major purchases and deliveries of aircraft and engines by the United States Army and Navy aviation services during the fiscal year 1932, prepared with the aid of the Army Air Corps and the Bureau of Aeronautics of the Navy Department.

ARMY AIR CORPS AERONAUTICAL CONTRACTS

Contract No.	Contractor	Article
W 535 ac-3978	Boeing Airplane Co., Seattle, Wash.	101 P-12E Airplanes
W 535 ac-4051	Douglas Aircraft Corp., Santa Monica, Calif.	15 O-38B Airplanes
W 535 ac-4067	Keystone Aircraft Corp., Bristol, Pa.	25 B-4A Airplanes
		39 B-6A Airplanes
W 535 ac-4099	Douglas Aircraft Corp., Santa Monica, Calif.	30 O-25C Airplanes
W 535 ac-4136	Curtiss Aeroplane & Motor Co., Inc., Buffalo, N. Y.	10 O-39 Airplanes
W 535 ac-4197	B/J Aircraft Corp., Baltimore, Md.	10 Y1P-16 Airplanes
W 535 ac-4326	Douglas Aircraft Corp., Santa Monica, Calif.	1 O-31B Airplane
W 535 ac-4434	Curtiss Aeroplane & Motor Co., Inc., Buffalo, N. Y.	46 P-63 Airplanes
W 535 ac-4460	Douglas Aircraft Corp., Santa Monica, Calif.	10 Amphibian Cargo (Y1C-21)
W 535 ac-4515	American Airplane & Engine Corp., New York, N. Y.	4 Y1C-24 Airplanes
W 535 ac-4534	Douglas Aircraft Corp., Santa Monica, Calif.	5 Y1O-31A Airplanes
W 535 ac-4536	Detroit Aircraft Corp., Detroit, Mich.	1 YA-9 Airplane
		4 Y1A-9 Airplanes
W 535 ac-4537	Boeing Airplane Co., Seattle, Wash.	1 YB-9 Airplane
		1 Y1B-9 Airplane
		5 Y1B-9A Airplanes
W 535 ac-4538	Douglas Aircraft Corp., Santa Monica, Calif.	7 Y1B-7 Airplanes
		5 Y1O-35 Airplanes
W 535 ac-4539	Detroit Aircraft Corp., Detroit, Mich.	1 YB-24 Airplane
		4 Y1B-24 Airplanes
W 535 ac-4553	Douglas Aircraft Corp., Santa Monica, Calif.	19 O-388 Airplanes
W 535 ac-4599	Curtiss Aeroplane & Motor Co., Buffalo, N. Y.	1 YO-40 Airplane
W 535 ac-4603	Curtiss Aeroplane & Motor Co., Buffalo, N. Y.	5 YA-8 Airplanes
		8 Y1A-8 Airplanes
W 535 ac-4626	Consolidated Aircraft Corp., Buffalo, N. Y.	10 PT-12 Airplanes
		5 PT-11B Airplanes
		22 PT-11D Airplanes

<i>Contract No.</i>	<i>Contractor</i>	<i>Article</i>
W 535 ac-4911	Thomas Morse Aircraft Corp., Buffalo, N. Y.	1 XO-924 Airplane (YO-4) (fuselage)
W 535 ac-4921	Douglas Aircraft Corp., Santa Monica, Calif.	2 Amphibian Transports (Dolphin)
W 535 ac-4998	Consolidated Aircraft Corp., Buffalo, N. Y.	4 Y1P-24 Airplanes
W 535 ac-5100	Douglas Aircraft Corp., Santa Monica, Calif.	8 Y1C-26A Airplanes
W 535 ac-5128	Bellanca Aircraft Corp., New Castle, Del.	4 Y1C-27 Airplanes
W 535 ac-5200	Boeing Airplane Co., Seattle, Wash.	3 Y1P-26 Airplanes
W 535 ac-5258	Curtiss Aeroplane & Motor Co., Inc., Buffalo, N. Y.	1 Y1O-40B Airplane
		3 Y1O-40A Airplanes
		1 Y1O-40A (skeleton)
W 535 ac-4928 (32-3853-P)	General Aviation Mfg. Corp.	1 Transport Airplane Ambulance C-15
W 535 ac-5187 (32-6194-P)	Sikorsky Aviation Corp., Bridgeport, Conn.	1 Transport, Sikorsky S-39-B Amphibian, type Y1C-28
W 535 ac-4445 (32-106-P)	Detroit Aircraft Corp., Detroit, Mich.	1 Lockheed Airplane, "Altair" metal, type Y1C-23
W 535 ac-4693 (32-1831-P)	Detroit Aircraft Corp., Detroit, Mich.	1 Y1C-25 Airplane

Engines and Spares

315 Curtiss Engines	43 Kinner Engines
388 Pratt & Whitney Engines	11 Lycoming Engines
174 Wright Engines	1 Continental Engine

AIRPLANES DELIVERED TO ARMY AIR CORPS

<i>Quantity</i>	<i>Type</i>	<i>Contractor</i>
101	P-12E.	Boeing Airplane Co., Seattle, Wash.
16	O-38B.	Douglas Aircraft Corp., Santa Monica, Calif. (1 for Coast Guard)
25	B-4A.	Keystone Aircraft Corp., Bristol, Pa.
39	B-6A.	Keystone Aircraft Corp., Bristol, Pa.
30	O-25C.	Douglas Aircraft Corp., Santa Monica, Calif.
10	O-39.	Curtiss Aeroplane & Motor Co., Inc., Buffalo, N. Y.
10	Y1P-16.	B/J Aircraft Corp., Baltimore, Md.
1	O-31B.	Douglas Aircraft Corp., Santa Monica, Calif.
46	P-63.	Curtiss Aeroplane & Motor Co., Inc., Buffalo, N. Y.
10	Amphibian Cargo (Y1C-21)	Douglas Aircraft Corp., Santa Monica, Calif.
4	Y1C-24.	American Airplane & Engine Co., Farmingdale, L.I., N. Y.
4	Y1O-31A.	Douglas Aircraft Corp., Santa Monica, Calif.
1	YB-9.	Boeing Airplane Co., Seattle, Wash.
1	Y1B-9.	Boeing Airplane Co., Seattle, Wash.
1	YB-24.	Detroit Aircraft Corp., Detroit, Michigan.
19	O-388.	Douglas Aircraft Corp., Santa Monica, Calif.
1	YO-40.	Curtiss Aeroplane & Motor Co., Inc., Buffalo, N. Y.
3	YA-8.	Curtiss Aeroplane & Motor Co., Inc., Buffalo, N. Y.
10	PT-12.	Consolidated Aircraft Corp., Buffalo, N. Y.
16	PT-11D.	Consolidated Aircraft Corp., Buffalo, N. Y.
1	XO-924 (YO-4) (fuselage)	Thomas Morse Aircraft Corp., Buffalo, N. Y.
1	Amphibian Transport (Dolphin)	Douglas Aircraft Corp., Santa Monica, Calif.
3	Y1P-26.	Boeing Airplane Co., Seattle, Wash.
1	Ambulance, C-15.	General Aviation Mfg. Corp., Dundalk, Md.
1	Lockheed "Altair" metal, type Y1C-23.	Detroit Aircraft Corp., Detroit, Mich.
1	Y1C-25.	Detroit Aircraft Corp., Detroit, Mich.

Injuries Classified

January to June, 1932, Inclusive

Kind of Flying	Total Persons Involved	Pilots					Co-Pilots or Students				
		Fatal	Severe	Minor	No Injury	Total	Fatal	Severe	Minor	No Injury	Total
Schedule	199	10	0	6	52	68	1	0	1	10	12
Student instruction	217	11	13	18	121	163	7	2	8	35	52
Experimental	44	4	4	6	25	39	0	0	0	0	0
Commercial	362	13	6	9	141	169	0	0	0	1	1
Pleasure	853	44	35	54	352	485	0	0	0	0	0
Total	1675	82	58	93	691	924	8	2	9	46	65

Kind of Flying	Total Persons Involved	Passengers					Aircraft Crew				
		Fatal	Severe	Minor	No Injury	Total	Fatal	Severe	Minor	No Injury	Total
Schedule	199	16	0	2	94	112	0	0	1	6	7
Student instruction	217	2	0	0	0	2	0	0	0	0	0
Experimental	44	1	0	1	3	5	0	0	0	0	0
Commercial	362	15	4	21	148	188	1	0	0	3	4
Pleasure	853	39	39	34	256	308	0	0	0	0	0
Total	1675	73	43	58	501	675	1	0	1	9	11

AERONAUTICAL PURCHASES BY MILITARY SERVICES IN 1932

The following is a compilation of major purchases and deliveries of aircraft and engines by the United States Army and Navy aviation services during the fiscal year 1932, prepared with the aid of the Army Air Corps and the Bureau of Aeronautics of the Navy Department.

ARMY AIR CORPS AERONAUTICAL CONTRACTS

Contract No.	Contractor	Article
W 535 ac-3978	Boeing Airplane Co., Seattle, Wash.	101 P-12E Airplanes
W 535 ac-4051	Douglas Aircraft Corp., Santa Monica, Calif.	15 O-38B Airplanes
W 535 ac-4067	Keystone Aircraft Corp., Bristol, Pa.	25 B-4A Airplanes
		39 B-6A Airplanes
W 535 ac-4099	Douglas Aircraft Corp., Santa Monica, Calif.	30 O-25C Airplanes
W 535 ac-4136	Curtiss Aeroplane & Motor Co., Inc., Buffalo, N. Y.	10 O-39 Airplanes
W 535 ac-4197	B/J Aircraft Corp., Baltimore, Md.	10 Y1P-16 Airplanes
W 535 ac-4326	Douglas Aircraft Corp., Santa Monica, Calif.	1 O-31B Airplane
W 535 ac-4434	Curtiss Aeroplane & Motor Co., Inc., Buffalo, N. Y.	46 P-63 Airplanes
W 535 ac-4460	Douglas Aircraft Corp., Santa Monica, Calif.	10 Amphibian Cargo (Y1C-21)
W 535 ac-4515	American Airplane & Engine Corp., New York, N. Y.	4 Y1C-24 Airplanes
W 535 ac-4534	Douglas Aircraft Corp., Santa Monica, Calif.	5 Y1O-31A Airplanes
W 535 ac-4536	Detroit Aircraft Corp., Detroit, Mich.	1 YA-9 Airplane
		4 Y1A-9 Airplanes
W 535 ac-4537	Boeing Airplane Co., Seattle, Wash.	1 YB-9 Airplane
		1 Y1B-9 Airplane
		5 Y1B-9A Airplanes
W 535 ac-4538	Douglas Aircraft Corp., Santa Monica, Calif.	7 Y1B-7 Airplanes
		5 Y1O-35 Airplanes
W 535 ac-4539	Detroit Aircraft Corp., Detroit, Mich.	1 YB-24 Airplane
		4 Y1B-24 Airplanes
W 535 ac-4553	Douglas Aircraft Corp., Santa Monica, Calif.	19 O-388 Airplanes
W 535 ac-4599	Curtiss Aeroplane & Motor Co., Buffalo, N. Y.	1 YO-40 Airplane
W 535 ac-4603	Curtiss Aeroplane & Motor Co., Buffalo, N. Y.	5 YA-8 Airplanes
		8 Y1A-8 Airplanes
W 535 ac-4626	Consolidated Aircraft Corp., Buffalo, N. Y.	10 PT-12 Airplanes
		5 PT-11B Airplanes
		22 PT-11D Airplanes

<i>Contract No.</i>	<i>Contractor</i>	<i>Article</i>
W 535 ac-4911	Thomas Morse Aircraft Corp., Buffalo, N. Y.....	1 XO-924 Airplane (YO-4) (fuselage)
W 535 ac-4921	Douglas Aircraft Corp., Santa Monica, Calif.....	2 Amphibian Transports (Dolphin)
W 535 ac-4998	Consolidated Aircraft Corp., Buffalo, N. Y.....	4 Y1P-24 Airplanes
W 535 ac-5100	Douglas Aircraft Corp., Santa Monica, Calif.....	8 Y1C-26A Airplanes
W 535 ac-5128	Bellanca Aircraft Corp., New Castle, Del.....	4 Y1C-27 Airplanes
W 535 ac-5200	Boeing Airplane Co., Seattle, Wash.....	3 Y1P-26 Airplanes
W 535 ac-5258	Curtiss Aeroplane & Motor Co., Inc., Buffalo, N. Y.	1 Y1O-40B Airplane
		3 Y1O-40A Airplanes
		1 Y1O-40A (skeleton)
W 535 ac-4928	General Aviation Mfg. Corp.....	1 Transport Airplane
(32-3853-P)		Ambulance C-15
W 535 ac-5187	Sikorsky Aviation Corp., Bridgeport, Conn.....	1 Transport, Sikorsky S-39-B Amphibian, type Y1C-28
(32-6194-P)		
W 535 ac-4445	Detroit Aircraft Corp., Detroit, Mich.....	1 Lockheed Airplane, "Altair" metal, type Y1C-23
(32-106-P)		
W 535 ac-4693	Detroit Aircraft Corp., Detroit, Mich.....	1 Y1C-25 Airplane
(32-1831-P)		

Engines and Spares

315 Curtiss Engines	43 Kinner Engines
388 Pratt & Whitney Engines	11 Lycoming Engines
174 Wright Engines	1 Continental Engine

AIRPLANES DELIVERED TO ARMY AIR CORPS

<i>Quantity</i>	<i>Type</i>	<i>Contractor</i>
101	P-12E.....	Boeing Airplane Co., Seattle, Wash.
16	O-38B.....	Douglas Aircraft Corp., Santa Monica, Calif. (1 for Coast Guard)
25	B-4A.....	Keystone Aircraft Corp., Bristol, Pa.
39	B-6A.....	Keystone Aircraft Corp., Bristol, Pa.
30	O-25C.....	Douglas Aircraft Corp., Santa Monica, Calif.
10	O-39.....	Curtiss Aeroplane & Motor Co., Inc., Buffalo, N. Y.
10	Y1P-16.....	B/J Aircraft Corp., Baltimore, Md.
1	O-31B.....	Douglas Aircraft Corp., Santa Monica, Calif.
46	P-63.....	Curtiss Aeroplane & Motor Co., Inc., Buffalo, N. Y.
10	Amphibian Cargo (Y1C-21).....	Douglas Aircraft Corp., Santa Monica, Calif.
4	Y1C-24.....	American Airplane & Engine Co., Farmingdale, L.I., N. Y.
4	Y1O-31A.....	Douglas Aircraft Corp., Santa Monica, Calif.
1	YB-9.....	Boeing Airplane Co., Seattle, Wash.
1	Y1B-9.....	Boeing Airplane Co., Seattle, Wash.
1	YB-24.....	Detroit Aircraft Corp., Detroit, Michigan.
19	O-388.....	Douglas Aircraft Corp., Santa Monica, Calif.
1	YO-40.....	Curtiss Aeroplane & Motor Co., Inc., Buffalo, N. Y.
3	YA-8.....	Curtiss Aeroplane & Motor Co., Inc., Buffalo, N. Y.
10	PT-12.....	Consolidated Aircraft Corp., Buffalo, N. Y.
16	PT-11D.....	Consolidated Aircraft Corp., Buffalo, N. Y.
1	XO-924 (YO-4) (fuselage).....	Thomas Morse Aircraft Corp., Buffalo, N. Y.
1	Amphibian Transport (Dolphin).....	Douglas Aircraft Corp., Santa Monica, Calif.
3	Y1P-26.....	Boeing Airplane Co., Seattle, Wash.
1	Ambulance, C-15.....	General Aviation Mfg. Corp., Dundalk, Md.
1	Lockheed "Altair," metal, type Y1C-23.....	Detroit Aircraft Corp., Detroit, Mich.
1	Y1C-25.....	Detroit Aircraft Corp., Detroit, Mich.

NAVY PURCHASES OF AERONAUTICAL EQUIPMENT

Airplanes

Contract Number	Date of Contract	Number Purchased	Model
22882	7-7-31	7	OL-9
22960	7-15-31	23	P2Y-1
21737	8-5-31	45	F4B-4
24021	10-12-31	6	F9C-2
24224	10-19-31	76	O3U-3
24144	10-17-31	15	O3U-2 (SU-1)
24145	10-17-31	16	BM-2
24280	10-26-31	18	OJ-2
24198	10-19-31	65	SU-2
24365	11-4-31	1	RS-3
24009	11-17-31	2	RR-5
25471	2-3-32	4	OL-9
26229	3-29-32	4	BM-1

282

Engines

Contract Number	Date of Contract	Number Purchased	Model
23089	7-18-31	21 (P & W)	R-1690-C
23261	8-3-31	1 (Wright)	R-975-E
23380	8-15-31	4 (P & W)	R-985-A
24225	10-19-31	50 (P & W)	R-1340-D
24411	11-4-31	26 (P & W)	R-1690-C
24365	11-4-31	2 (P & W)	R-1340-C
24608	11-17-31	46 (P & W)	R-1690-C
24702	11-28-31	97 (P & W)	R-1690-C
24788	11-30-31	5 (P & W)	R-1340-D-1
24744	12-7-31	27 (P & W)	R-985-A
25220	1-16-32	9 (Wright)	R-975-E-3
25469	2-4-32	6 (P & W)	R-1340-D
25482	2-6-32	10 (Wright)	R-760-E
25419	2-1-32	2 (P & W)	R-1860-B
26875	5-16-32	10 (P & W)	R-1535
27122	6-2-32	10 (Wright)	R-1510
27259	6-9-32	114 (P & W)	R-1340-D-1

440

Airplanes Delivered to U. S. Navy

Type	Quantity Delivered	Contractor
Fighters	21	Boeing Aircraft Co.
Observation	16	Chance Vought Corp.
Scouting	29	Chance Vought Corp.
Torpedo	32	Great Lakes Aircraft Corp.
Torpedo	16	Glenn L. Martin Co.
Patrol	17	Keystone Aircraft Corp., Inc.
Patrol	46	Glenn L. Martin Co.
Patrol	9	Hall-Aluminum Aircraft Corp.
Transport	6	Sikorsky Aviation Corp.
Amphibian	21	Loening Aeronautical Eng. Corp.
Autogiro	2	Pitcairn Aircraft Co.

Aircraft Engines Delivered to U. S. Navy

Type	Quantity Delivered	Contractor
R-985-A	17	Pratt & Whitney Aircraft Co.
R-1340-C	2	Pratt & Whitney Aircraft Co.
R-1340-D	153	Pratt & Whitney Aircraft Co.
R-1340-D-1	5	Pratt & Whitney Aircraft Co.
R-1340-D-2	11	Pratt & Whitney Aircraft Co.
SR-1340-E	2	Pratt & Whitney Aircraft Co.
R-1690-A-2	19	Pratt & Whitney Aircraft Co.
R-1690-C	133	Pratt & Whitney Aircraft Co.
R-975-E	2	Wright Aeronautical Corp.
R-1820-E, Direct drive	99	Wright Aeronautical Corp.
R-1820-E, Geared	78	Wright Aeronautical Corp.
GIR-1820-E-1	23	Wright Aeronautical Corp.
R-1820-F	2	Wright Aeronautical Corp.

Strength of Naval Aviation

Fiscal Years 1922-1932

Officers Attached to Aviation

	June 30, 1922	June 30, 1923	June 30, 1924	June 30, 1925	June 30, 1926	June 30, 1927	June 30, 1928	June 30, 1929	June 30, 1930	June 30, 1931	June 30, 1932
Naval aviators.....	314	326	328	382	426	472	466	520	614	737	803
Student naval aviators.....	61	33	47	35	71	28	73	116	184	149	84
Line, ground.....	105	91	42	17	14	12	24	54*	60	254	230
Staff, ground.....	115	134	101	99	129	138	128	101*	98	120	111
Naval observers.....	6	5	5	11	12	11	11	9	5	7
Student naval observers.....	2
Officers having flight orders....	10	13	16	19	15	33	41	45	48	48
Total.....	595	600	536	554	670	677	737	843	1,019	1,313	1,283

* Approximate figures.

Enlisted Men on Duty

	June 30, 1922	June 30, 1923	June 30, 1924	June 30, 1925	June 30, 1926	June 30, 1927	June 30, 1928	June 30, 1929	June 30, 1930	June 30, 1931	June 30, 1932
Aviation ratings.....	2,209	1,612	1,788	1,711	1,722	2,092	2,785	3,067	2,895	3,136	3,313
General service ratings.....	2,422	2,104	1,814	1,597	2,155	2,333	8,636	8,575	7,874	9,503	9,045
Total.....	4,631	3,716	3,602	3,308	3,877	4,425	11,421	11,642	10,769	12,639	12,358

Marine Corps Aviation

Fiscal Year 1931	Officers	Enlisted Men	Total	Fiscal Year 1932	Officers	Enlisted Men	Total
Pilots.....	98	33	131	Pilots.....	101	32	133
Student pilots.....	10	0	10	Student pilots.....	12	0	12
Flight orders.....	7	157	164	Flight orders.....	7	157	164
Non-flyers.....	8	842	850	Non-flyers.....	10	760	770
Total.....	123	1,032	1,155	Total.....	130	949	1,079

Trend of Aircraft Accident Rates

In the U. S. Army Air Corps

<i>Fiscal Years.....</i>	1921	1922	1923	1924	1925	1926	1927	1928	1929	1930	1931	1932
Aircraft hours.....	77,351	65,214	65,750	97,834	150,319	158,402	140,402	182,903	263,381	325,224	396,961	371,254
Fatal accidents.....	45	24	33	23	29	27	28	25	42	37	21	33
Rate per 1000 hours.....	.582	.368	.502	.235	.193	.171	.199	.137	.230	.114	.053	.086
Hours per fatal accident.....	1,718	2,714	1,992	4,250	5,180	5,865	5,030	7,320	4,355	8,785	18,900	11,061
All accidents.....	361	330	283	275	311	334	227	249	390	468	456	423
Rate per 1000 hours.....	4.67	5.06	4.31	2.81	2.07	2.11	1.61	1.36	1.48	1.44	1.15	1.14
Hours per accident.....	214	198	232	356	483	474	620	734	675	695	870	877
Ratio—accidents to fatal accidents.	1 to 8	1 to 13.8	1 to 8.6	1 to 12.0	1 to 10.7	1 to 12.4	1 to 8.1	1 to 10.0	1 to 9.3	1 to 12.6	1 to 21.7	1 to 12.8

AERONAUTICAL EDUCATION IN AMERICAN UNIVERSITIES
AND COLLEGES

The following table of statistics on aeronautical education in American universities and colleges was compiled from the last three annual surveys made by the Aeronautical Chamber of Commerce of America, Inc., in 1930, 1931 and 1932 for "The Aircraft Year Book." The annual survey for 1929-1930 appeared in preceding Year Books. Those starred (*) offer full courses leading to a degree in aeronautical engineering. Years given are the twelve-month period beginning with the opening of the second semester, or spring quarter, of one academic year and extending over to the beginning of the same period in the next year.

Name of Institution	Full Time	Part Time	Students	Students	Students
	Instructors	Instructors	Enrolled	Enrolled	Enrolled
	1932-33	1932-33	1930-31	1931-32	1932-33
Alabama Polytechnic Institute.....	118	192	..
University of Alabama *.....	15	1	132	264	327
University of Arizona.....	15	18	..
University of Arkansas.....	0	1	15
Armour Institute of Technology.....	1	4	38	44	28
Boston University.....	20	..
Bradley Polytechnic Institute.....	0	1	30	20	20
University of California.....	0	4	80	40	65
California Institute of Technology *...	0	0	15	15	39
Carnegie Institute of Technology *....	0	2	130	151	139
Case School of Applied Science.....	0	2	..	7	51
Catholic University of America.....	4	15	..
University of Cincinnati *.....	2	6	110	224	267
Clemson Agricultural College of S. C....	0	1	15
University of Colorado.....	1	2	..	65	23
Connecticut Agricultural College.....	11	15	..
Cornell University.....	0	1	22	25	18
College of the City of Detroit*.....	1	1	40	90	101
University of Detroit*.....	3	3	640	588	380
University of Florida.....	0	2	11	35	51
Georgia School of Technology *.....	2	1	17	49	73
Harvard University.....	26	..
Hiram College (Ohio).....	50	..
University of Idaho.....	0	2	15	23	27
University of Illinois.....	0	1	37	20	33
Iowa State College.....	1	1	42	73	49
University of Iowa.....	0	1	..	10	8
University of Kansas.....	0	4	23	19	24
Kansas State College.....	0	3	10	20	24
Lafayette College.....	0	1	12
Lake Forest College.....	0	1	36	48	18
Lehigh University.....	0	2	13	13	330
Marquette University.....	54	43	..
Massachusetts Inst. of Technology *...	13	4	272	286	375
University of Miami.....	76	41	y
Michigan College of Mining.....	0	1	15
University of Michigan *.....	4	0	491	433	376
University of Minnesota *.....	2	4	237	408	420
Montana State College.....	0	1	20	11	0
Morningside College.....	0	1	12	25	20
University of Nebraska.....	0	3	3	..	19
University of Nevada.....	0	1	10	3	7
University of New Hampshire.....	0	3	40	37	24
New Mexico College of A. & M. A.....	0	1	8	..	20
New York University *.....	194	235	235
North Carolina State College.....	0	2	61	135	38
University of North Carolina.....	32	50	..
Ohio State University.....	1	0	15	15	16
Oklahoma A. & M. College.....	0	2	16	15	..
University of Oklahoma.....	0	3	20	24	24
Oregon University.....	97	103	..
Oregon State College.....	1	2	53	41	61
College of the Pacific.....	12	..
Pennsylvania State College.....	0	1	12	..	21
University of Pittsburgh *.....	1	3	175	125	107
Polytechnic Institute of Brooklyn.....	6	y
Princeton University.....	1	0	..	16	27
Purdue University.....	48	74	..
Rose Polytechnic Institute.....	14	20	..
Rutgers University.....	6	..
St. Johns College.....	..	1	50
University of South Dakota.....	1	16	30	42	66
University of Southern California *...	0	1	170	189	118
Stanford University *.....	3	0	14	14	26
Swarthmore College.....	6	..

AIRCRAFT YEAR BOOK

<i>Name of Institution</i>	<i>Full Time</i>	<i>Part Time</i>	<i>Students</i>	<i>Students</i>	<i>Students</i>
	<i>Instructors</i> 1932-33	<i>Instructors</i> 1932-33	<i>Enrolled</i> 1930-31	<i>Enrolled</i> 1931-32	<i>Enrolled</i> 1932-33
Syracuse University.....	0	3	40	40	55
University of Tennessee.....	0	2
A. & M. College of Texas.....	0	1	..	32	13
University of Texas.....	0	1	7
University of Toledo.....	0	1	37
United States Military Academy.....	0	11	300	300	605
United States Naval Academy.....	4	52	447	1,450	1,440
University of Utah.....	0	2	15	12	5
Utah State Agricultural College.....	1	0	29	41	30
Valparaiso University.....	7	..
Virginia Polytechnic Institute.....	0	2	30	30	37
University of Virginia.....	10	18	..
Washington University (St. Louis).....	32	48	..
University of Washington (Seattle)*.....	2	1	95	200	274
State College of Washington.....	0	1	30	30	27
Municipal University of Wichita *.....	1	3	..	27	57
College of William & Mary.....	1	1	..	48	123
University of Wisconsin.....	0	7	151	18	39
Worcester Polytechnic Institute *.....	0	5	6	10	9
Yale University.....	0	2	4	30	17
Totals.....	66	194	5,116	7,020	6,978

y Courses not given 1931-32.

PART V

Aeronautical Directory and Trade Index

Aeronautical Directory

SUBJECT	PAGE
Aeronautical Chamber of Commerce of America, Inc.	447
Aeronautical Expositions Corporation	452
Aeronautical Magazines in U. S.	452
Aeronautical Magazines in Foreign Countries	453
Aviation Editors of Newspapers and Press Assns.	454
Airports and Airport Managers by States.	458
Airports in Alaska.	469
Anchorage for Seaplanes in U. S.	470
Army Air Corps Officials, Divisions, Posts	472
Aviation Country Clubs	475
Department of Commerce Aeronautic Officials	477
Diplomatic Service to the United States	477
Diplomatic Service of the United States	477
Flying Schools Granted Certificates	478
Manufacturers Aircraft Association	479
National Advisory Committee for Aeronautics	480
National Aeronautic Association of U. S. A., Inc.	480
Navy and Marine Corps Officials, Stations, Etc.	481
Post Office Department Air Mail Officials	482
Society of Automotive Engineers, Inc.	482
Weather Bureau Officials in U. S.	483

Trade Index

Aircraft and Engine Manufacturers	484
Manufacturers of Accessories, Materials, Supplies	486
Air Transport Operators and Fuels and Lubricants	490
Exporters, Publishers and Miscellaneous	491

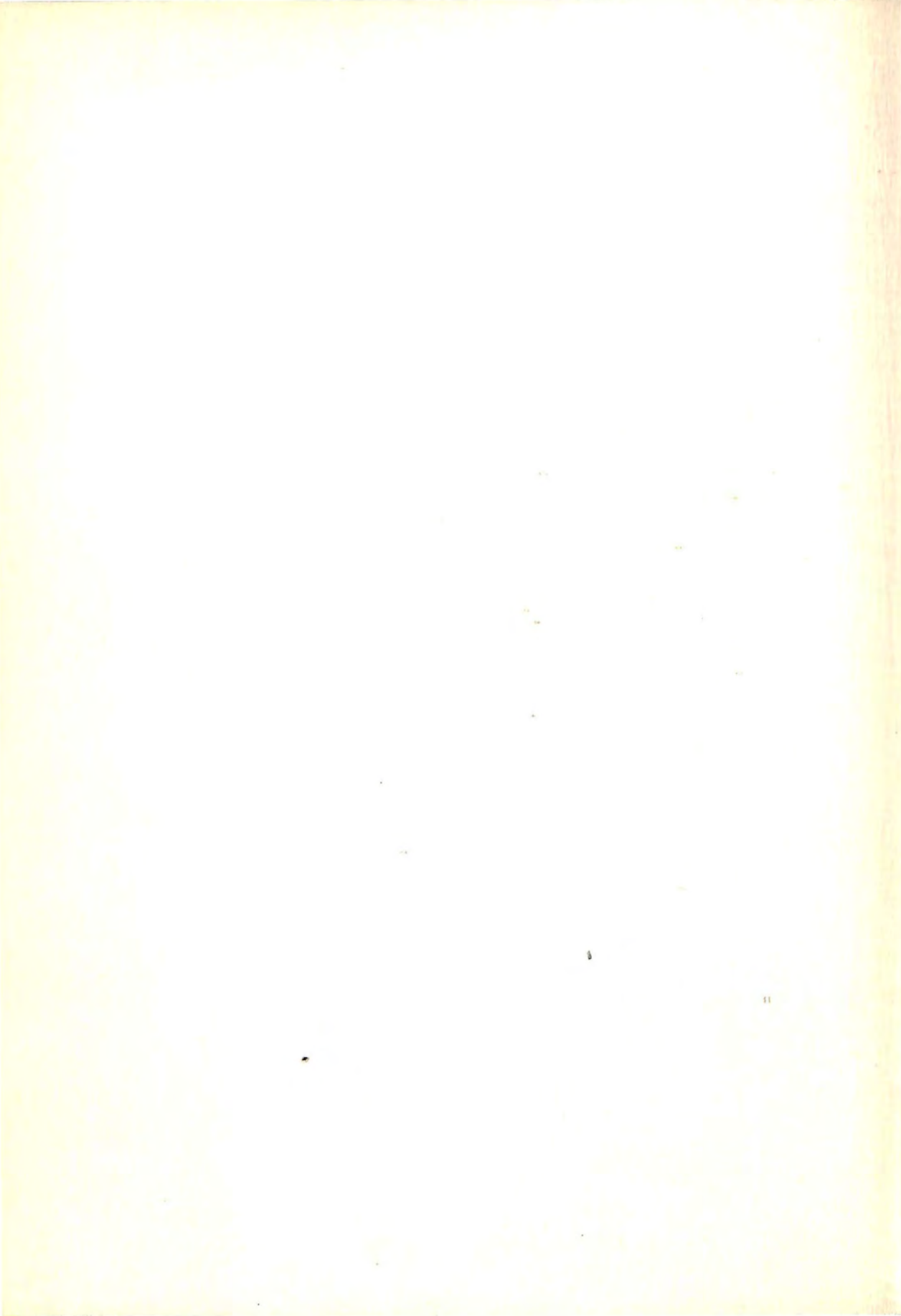

**AERONAUTICAL CHAMBER OF COMMERCE
OF AMERICA, INC.**



22 East Fortieth Street, New York

Officers for 1932

(Elected at Annual Meeting of Members, January 28, 1932)

President	Charles L. Lawrance
Vice President, Northeast Division	Grover Loening
Vice President, Southeast Division	Thomas B. Doe
Vice President, East Central Division	Clayton J. Brukner
Vice President, North Central Division	R. C. Marshall
Vice President, South Central Division	Halsey Dunwoody
Vice President, Northwest Division	P. G. Johnson
Vice President, Southwest Division	H. M. Hanshue
Secretary	Oliver L. Parks
Treasurer	J. A. B. Smith
General Manager and Assistant Secretary	Luther K. Bell

Governors for 1932

J. S. Allard
Clayton J. Brukner
Reed M. Chambers
Geoffrey S. Childs
F. G. Coburn
Thomas B. Doe
James M. Eaton
Sherman M. Fairchild
J. C. Hunsaker

W. B. Hurlburt
P. G. Johnson
Charles L. Lawrance
Grover Loening
L. B. Manning
Charles Marcus
William B. Mayo
*Frank M. McKee
Thomas A. Morgan

George W. Orr
Earl D. Osborn
Richard W. Robbins
Frank H. Russell
J. M. Schoonmaker, Jr.
J. T. Trippe
George S. Wheat
R. A. Wotowitch
H. E. Young

* Deceased.

The Council

(Past Presidents)

S. S. Bradley
L. D. Gardner
Paul Henderson
F. H. Russell

C. L. Lawrance
Grover Loening
F. B. Rentschler
I. M. Uppercu

Committees for 1932

Executive

Charles L. Lawrance, Chairman; F. G. Coburn, Jerome C. Hunsaker, Grover Loening, T. A. Morgan, J. M. Schoonmaker, Jr., George S. Wheat.

Airplane Manufacturers Section

Col. V. E. Clark, Chairman; G. M. Belanca, C. J. Brukner, S. M. Fairchild, P. G. Johnson, Temple N. Joyce, T. A. Morgan.

Commercial Committee

C. J. Brukner, Chairman; E. T. Asplundh, R. S. Damon, B. O. DeWeese, S. M. Fairchild, R. B. Galloway, J. E. Schaefer.

Engineering Committee

R. S. Damon, Chairman; A. F. Arcier, H. A. Hicks, A. E. Larsen, T. P. Leaman, C. N. Monteith, A. H. Saxon.

Merchandising Committee

W. B. Hurlburt, Chairman; J. D. Alexander, R. E. Lees, W. A. Mara, J. J. O'Brien, H. R. Perry, J. E. Schaefer.

Airplane Engine Manufacturers Section

Don L. Brown, Chairman; W. H. Beals, Robert Insley, Edward Macauley, Robert Porter, Guy Vaughan, Jr., W. O. Warner.

Air Transport Section

Capt. Thomas B. Doe, Chairman; Temple Bowen, James M. Eaton, Alfred Frank, H. M. Hanshue, P. G. Johnson, E. P. Lott, R. C. Marshall, Maj. H. S. Martin, Richard W. Robbins, Paul D. Selby, Lester D. Seymour, Juan T. Trippe.

Business Practises Committee

Frank G. Wilson, Chairman; Alex. Cushny, Alfred Frank, O. J. Gurwell, J. H. Johnson, J. F. McCarthy, J. W. Miller, C. Bedell Monro, Harry S. Moyer, F. W. Whitmore.

Insurance Committee

Alex Cushny, Chairman; Maj. W. J. Barry, Alfred Frank, C. J. Gurwell, J. W. Miller, L. H. Mueller, C. Bedell Munro, F. W. Whitmore, J. S. Woodbridge.

Maintenance Sub-Committee

C. M. Belinn, Chairman; C. H. Dolan, Jr., R. D. Edwards, W. A. Hamilton, C. N. James, Carl Lund, W. F. McDuffee, Joseph F. Martin, A. A. Priestler, J. L. Ruden, Paul Selby, H. B. Taylor.

Operations Committee

Harold Elliott, Chairman; Clifford Ball, Temple Bowen, Paul F. Collins, Jack Frye, Thorp Hiscock, C. N. James, A. A. Priestler, J. L. Ruden, Paul Selby, C. R. Smith, Felix Steinle.

Radio and Electrical Maintenance Committee

Clayton C. Shangraw, Chairman; C. M. Belinn, George S. Evans, J. C. Franklin, F. E. Gray, B. C. Hawkins, Thorp Hiscock, Robert G. Horton, H. C. Leuteritz, Everett J. Seely, Paul D. Selby.

Traffic Committee

L. E. Gill, Chairman; W. J. Austin, Arthur G. Beggs, V. E. Chenea, T. B. Clement, W. G. Ferguson, M. R. Garnett, W. Sanger Green, K. A. Kennedy, Warren Oakes, Charles Rheinstrom, L. G. Simon.

Organization Members**Aircraft and Engine Manufacturers**

A. C. E. Corporation, Marysville, Mich.
 Aeronautical Corporation of America, Cincinnati, Ohio
 American Airplane & Engine Company, Farmingdale, N. Y.
 Amphibions, Inc., Garden City, L. I., N. Y.
 Aircraft Development Corporation, Detroit, Mich.
 Allison Engineering Company, Indianapolis, Ind.
 Autogiro Co. of America, Willow Grove, Pa.
 B/J Aircraft Corporation, Baltimore, Md.
 Bellanca Aircraft Corporation, New Castle, Dela.
 Bird Aircraft Corporation, Keyport, N. J.
 Boeing Airplane Company, Seattle, Wash.
 Brazil Aircraft Corporation, Brazil, Ind.
 Continental Aircraft Engine Company, Detroit, Mich.
 Curtiss Aeroplane & Motor Company, Inc., Buffalo, N. Y.
 Curtiss-Wright Airplane Company, Robertson, Mo.
 Detroit Aircraft Corporation, Detroit, Mich.
 Fairchild Aviation Corporation, Woodside, L. I., N. Y.
 Ford Motor Company, Dearborn, Mich.
 General Aviation Manufacturing Corporation, Dundalk, Md.
 Goodyear Zeppelin Corporation, New York, N. Y.
 Great Lakes Aircraft Corporation, Cleveland, Ohio
 Guiberson Diesel Engine Company, Dallas, Texas

Hall-Aluminum Aircraft Corporation, Buffalo, N. Y.
 Jacobs Aircraft Engine Company, Pottstown, Pa.
 Kellett Autogiro Corporation, Philadelphia, Pa.
 Keystone Aircraft Corporation, Bristol, Pa.
 Kinner Airplane & Motor Corporation, Glendale, Calif.
 Lawrance Engineering & Research Corporation, New York, N. Y.
 Lockheed Aircraft Company, Burbank, Calif.
 Loening (Grover) Aircraft Company, Inc., Garden City, L. I., N. Y.
 Lycoming Manufacturing Company, Williamsport, Pa.
 Monocoupe Corporation, Robertson, Mo.
 Packard Motor Car Company, Detroit, Mich.
 Pitcairn Aircraft, Inc., Willow Grove, Pa.
 Pratt & Whitney Aircraft Company, Hartford, Conn.
 St. Louis Aircraft Corporation, St. Louis, Mo.
 Sikorsky Aviation Corporation, Bridgeport, Conn.
 Spartan Aircraft Company, Tulsa, Okla.
 Stearman Aircraft Company, Wichita, Kans.
 Stinson Aircraft Corporation, Wayne, Mich.
 Taylor Aircraft Company, Bradford, Pa.
 Vought (Chance) Corporation, Hartford, Conn.
 Waco Aircraft Company, Troy, Ohio
 Warner Aircraft Corporation, Detroit, Mich.
 Wright Aeronautical Corporation, Paterson, N. J.

Air Transport Operators

American Airways, Inc., New York, N. Y.
 Boeing Air Transport, Inc., Chicago, Ill.
 Bowen Air Lines, Inc., Forth Worth, Tex.
 Eastern Air Transport, Inc., Brooklyn, N. Y.
 Ludington Airlines, Inc., So. Washington, Va.
 National Air Transport, Chicago, Ill.
 National Parks Airways, Inc., Salt Lake City, Utah
 Pacific Air Transport, Chicago, Ill.

Pan-American Airways, Inc., New York, N. Y.
 Pennsylvania Airlines, Pittsburgh, Pa.
 Rapid Air Lines Corporation, Omaha, Nebr.
 Transamerican Airlines Corporation, Detroit, Mich.
 Transcontinental and Western Air, Inc., New York, N. Y.
 Varney Airlines, Inc., Chicago, Ill.
 Western Air Express, Inc., Burbank, Calif.

Aeronautical Exporters

Barr Shipping Corporation, New York, N. Y.
 Curtiss-Wright Export Corporation, New York, N. Y.

United Aircraft Exports, Inc., New York, N. Y.

Aircraft Fuels and Lubricants

- | | |
|---|---|
| Cities Service Company, New York, N. Y. | Standard Oil Company of California, San Francisco, Calif. |
| Gulf Refining Company, New York, N. Y. | Standard Oil Company (Indiana), Chicago, Ill. |
| Kendall Refining Company, Bradford, Pa. | Standard Oil Company of New Jersey, New York, N. Y. |
| Shell Petroleum Corporation, St. Louis, Mo. | Texas Company, The, New York, N. Y. |
| Sinclair Refining Company, New York, N. Y. | |
| Soco-Vacuum Corporation, New York, N. Y. | |

Airports

- | | |
|---|--|
| Agawam Airport, Springfield, Mass. | Metropolitan Airport, Van Nuys, Calif. |
| Allegheny County Municipal Airport, Pittsburgh, Pa. | Miami, City of, Miami, Fla. |
| Boeing Field, Seattle, Wash. | Municipal Airport, Birmingham, Ala. |
| Central Airport, Inc., Camden, N. J. | Newark, City of, Dept. of Public Affairs, Newark, N. J. |
| Cleveland Municipal Airport, Cleveland, Ohio | Pal-Waukee Airport, Chicago, Ill. |
| Detroit City Airport, Detroit, Mich. | Roosevelt Field, Inc., Mineola, L. I., N. Y. |
| Floyd Bennett Field, Brooklyn, N. Y. | Sacramento Municipal Airport, Sacramento, Calif. |
| Fort Wayne Board of Aviation Commissioners, Ft. Wayne, Ind. | St. Paul Municipal Airport, St. Paul, Minn. |
| Grand Central Air Terminal, Glendale, Calif. | San Francisco Bay Airdrome, Inc., Alameda, Calif. |
| Hartford Municipal Airport, Hartford, Conn. | San Francisco Municipal Airport, San Bruno, Calif. |
| Indianapolis Municipal Airport, Indianapolis, Ind. | Tacoma Field, Tacoma, Wash. |
| Kansas City Municipal Airport, Kansas City, Mo. | Tulsa Municipal Airport, Tulsa, Okla. |
| Kellogg Airport Association, Battle Creek, Mich. | United Airports Company of California, Ltd., Burbank, Calif. |
| Los Angeles Airport, Inglewood, Calif. | Wichita Municipal Airport, Wichita, Kans. |
| Mercer County Airport, Trenton, N. J. | Wayne County Airport, Detroit, Mich. |

Aerial Service

- | | |
|---|---|
| Abrams Aerial Survey Corporation, Lansing, Mich. | Midwest Airways, Inc., Cudahy, Wisc. |
| Ames-Skyways, Inc., Boston, Mass. | Newark Air Service, Inc., Newark, N. J. |
| Bredouw-Hilliard Aeromotive Corporation, Kansas City, Mo. | Northwest Air Service, Inc., Seattle, Wash. |
| California Panel & Veneer Company, Los Angeles, Calif. | Nutter, Allen, Redlands, Calif. |
| Central Air Terminal Company, Chicago, Ill. | Pacific Aeromotive Corporation, Inglewood, Calif. |
| Curtiss-Wright Flying Service, Inc., New York, N. Y. | Parks Air College, Inc., E. St. Louis, Ill. |
| Giro Sales & Service, Inc., Garden City, L. I., N. Y. | Pynchon (Geo. M., Jr.), Inc., New York, N. Y. |
| Guggenheim (Daniel) School of Aeronautics, Atlanta, Ga. | Rogers Aircraft Company, Inc., Burbank, Calif. |
| Inter-Island Airways, Ltd., Honolulu, T. H. | Skyway, Inc., Cleveland, Ohio |
| Knickerbocker Aviation, Inc., Flushing, N. Y. | Starlighters, Inc., Philadelphia, Pa. |
| Lent, Ward S., Poughkeepsie, N. Y. | Stewart Technical Trade School, New York, N. Y. |
| Logan (Floyd) Aviation Company, Cleveland, Ohio | Utah Pacific Airways, Inc., Ogden, Utah |
| Macbeth Brothers, Dallas, Texas | Viking Flying Boat, New Haven, Conn. |
| Michigan Aeronautical Corporation, Ypsilanti, Mich. | Von Hoffmann Aircraft Company, Robertson, Mo. |
| | Wings Corporation of Philadelphia, Blue Bell, Pa. |
| | Yellow Cab Airways, Inc., Des Moines, Ia. |

Manufacturers of Accessories, Materials and Supplies

- | | |
|---|--|
| Aero Supply Manufacturing Company, Inc., Corry, Pa. | B. G. Corporation, The, New York, N. Y. I., Baum (Seymour J.) Inc., Elmhurst, L. N. Y. |
| Air Associates, Garden City, L. I., N. Y. | Bendix Brake Company, South Bend, Ind. |
| Air Reduction Sales Company, New York, N. Y. | Bendix Stromberg Carburetor Company, South Bend, Ind. |
| Air Transport Equipment, Inc., Garden City, N. Y. | Berry Brothers, Inc., Detroit, Mich. |
| Aircraft Radio Corporation, Boonton, N. J. | Bohn Aluminum and Brass Corporation, Detroit, Mich. |
| Airplane Wheel & Rim Corporation, Binghamton, N. Y. | Breeze Corporations, Inc., Newark, N. J. |
| American Gas Accumulator Company, Elizabeth, N. J. | Carpenter Steel Company, The, Reading, Pa. |
| Aluminum Company of America, Pittsburgh, Pa. | Champion Spark Plug Company, Toledo, Ohio |
| American Telephone & Telegraph Co., New York, N. Y. | Cleveland Pneumatic Tool Company, Cleveland, Ohio |
| "Automatic" Sprinkler Corporation of America, Cleveland, Ohio | Dow Chemical Company, Midland, Mich. |
| Aqua Systems, Inc., New York, N. Y. | Eastman Kodak Company, Rochester, N. Y. |
| | Eclipse Aviation Corporation, East Orange, N. J. |

- Edo Aircraft Company, College Point, N. Y.
 Egyptian Lacquer Manufacturing Company, Inc., New York, N. Y.
 Electric Storage Battery Company, Philadelphia, Pa.
 Elgin National Watch Company, Elgin, Ill.
 Ex-Cell-O Aircraft & Tool Corporation, Detroit, Mich.
 Firestone Tire and Rubber Company, The, Akron, Ohio
 Goodrich (The B. F.) Company, Akron, Ohio
 Goodyear Tire and Rubber Company, Inc., Akron, Ohio
 Hamilton Standard Propeller Corporation, East Hartford, Conn.
 Hartshorn (Stewart) Company, East Newark, N. J.
 Haskelite Manufacturing Corporation, Chicago, Ill.
 Hill Aircraft Streamliners Company, Cincinnati, Ohio
 Hurley-Townsend Corporation, New York, N. Y.
 Imperial Brass Manufacturing Company, Chicago, Ill.
 International Flare-Signal Company, Tippicanoe City, Ohio
 International Seed Company, Inc., New York, N. Y.
 Irving Air Chute Company, Inc., Buffalo, N. Y.
 Johnson Airplane and Supply Company, Dayton, Ohio
 Kidde (Walter) and Company, Inc., New York, N. Y.
 Leece-Neville Company, The, Cleveland, Ohio
 Macwhyte Company, Kenosha, Wisc.
 Meissel Press Manufacturing Company, Boston, Mass.
- Metallurgical Laboratories, Inc., Philadelphia, Pa.
 Norma-Hoffman Bearings Corporation, Stamford, Conn.
 Ohio Seamless Tube Company, The, Shelby, Ohio
 Parker Appliance Company, Cleveland, Ohio
 Pioneer Instrument Company, Brooklyn, N. Y.
 Pittsburgh Screw and Bolt Company, Pittsburgh, Pa.
 Pyle-National Company, The, Chicago, Ill.
 Roebling's (John A.) Sons Company, Trenton, N. J.
 SKF Industries, Inc., New York, N. Y.
 Scintilla Magneto Company, Sidney, N. Y.
 Sky Specialties Corporation, Detroit, Mich.
 Smith Engineering Company, Cleveland, Ohio
 Sperry Gyroscope Company, Inc., Brooklyn, N. Y.
 Summerill Tubing Company, Bridgeport, Pa.
 Switlik Parachute and Equipment Company, Trenton, N. J.
 Thompson Products, Inc., Cleveland, Ohio
 Thurston Cutting Corporation, New York, N. Y.
 Timken Roller Bearing Company, Canton, Ohio
 Union Carbide Company, New York, N. Y.
 United Aircraft Products, Inc., Dayton, Ohio
 Vellumoid Company, The, Worcester, Mass.
 Viking Corporation, Hastings, Mich.
 Western Electric Company, New York, N. Y.
 Westinghouse Electric and Manufacturing Company, Cleveland, Ohio
 Wood and Spencer Company, The, Cleveland, Ohio
 Wyman-Gordon Company, Worcester, Mass.

Special Services to Aviation, Miscellaneous, etc.

- Austin Company, Cleveland, Ohio
 Beech-Nut Packing Company, Canajoharie, N. Y.
 Bigelow (A. A.) and Company, Inc., New York, N. Y.
 Bigham, Englar, Jones & Houston, New York, N. Y.
 Champion Model Aircraft Supply, Chilli-cothe, Ohio
 Cutajar and Provost, Inc., New York, N. Y.
 Fishler, Farnsworth & Company, Inc., New York, N. Y.
 Globe Mail Service, Inc., New York, N. Y.
- Junior Air Service of America, Inc., Chicago, Ill.
 Loomis, Suffern & Fernald, New York, N. Y.
 Luke, Banks & Weeks, New York, N. Y.
 Marketing Associates, Inc., Cleveland, Ohio
 McCann-Erickson, Inc., New York, N. Y.
 National Credit Office, Inc., Cleveland, Ohio
 Pennsylvania Railroad Company, The, Philadelphia, Pa.
 Securities Sportswear Company, Chicago, Ill.
 Standard Statistics Company, Inc., New York, N. Y.
 Universal Accounting Systems, Inc., Washington, D. C.

Aero Insurers and Financial Institutions

- Aero Indemnity Company, New York, N. Y.
 Aetna Casualty and Surety Company, Hartford, Conn.
 Automobile Insurance Company, The, Hartford, Conn.
 Aviation Capital, Inc., New York, N. Y.
 Barber & Baldwin, New York, N. Y.
 Crum & Forster, New York, N. Y.
 Hartford Accident and Indemnity Company, Hartford, Conn.
- Maryland Casualty Company, Baltimore, Md.
 Pacific Fire Insurance Company, New York, N. Y.
 Phoenix Insurance Company, The, Hartford, Conn.
 St. Paul Fire and Marine Insurance Company, St. Paul, Minn.
 Travelers Insurance Company, Hartford, Conn.
 United States Aviation Underwriters, Inc., New York, N. Y.

Aeronautical Periodicals and Trade Papers

- Aeronautical Digest Publishing Corporation, New York, N. Y.
 Airport Directory Company, Hackensack, N. J.
 Aviation, New York, N. Y.
- Air Transportation, New York, N. Y.
 Occidental Publishing Company, Los Angeles, Calif.
 Southern Aviation, Atlanta, Ga.
 U. S. Air Services, Washington, D. C.

Associate Members

- American Road Builder's Association, Washington, D. C.
 Aviation Commissioner, Charles L. Morris, Hartford, Conn.
 Baltimore Association of Commerce, Baltimore, Md.
 Buffalo Municipal Airport, East Buffalo, N. Y.
 Chamber of Commerce of Kansas City, Missouri, Kansas City, Mo.
 Chicago Tribune, New York, N. Y.
 City of Denver, Colorado, Denver, Colo.
 City of Oakland, California, Oakland, Calif.
 College of Engineering, University of Oklahoma, Norman, Okla.
 College of Engineering and Architecture, University of Minnesota, Minneapolis, Minn.
 Detroit Board of Commerce, Detroit, Mich.
 Hotel Hussmann, El Paso, Texas
 Los Angeles Public Library, Los Angeles, Calif.
 Manufacturers Aircraft Association, New York, N. Y.
 Ohio Bureau of Aeronautics, Columbus, Ohio
 Rochester Municipal Airport, Rochester, N. Y.
 State Aviation Commission of New Jersey, Trenton, N. J.
 Transcontinental Airport of Toledo, Inc., Toledo, Ohio
 Tri-State College of Engineering, Angola, Ind.
 Women's National Aeronautical Association, Miami, Fla.

Affiliate Members

- Adams, Porter H.
 Alfaro, Heraclio
 Allwine, E. Ernest
 Althouse, Andrew D.
 Anderson, H. L.
 Anderson, J. Roscoe
 Arthur, W. E.
 Asplundh, Edwin T.
 Atkinson, L. M.
 Bain, Mary Wright
 Beckers, Dr. William G.
 Beebe, David C.
 Beccroft, David
 Bell, A. T.
 Bell, Laurence D.
 Bell, Luther K.
 Bellanca, G. M.
 Bennett, Chas. H., Jr.
 Bernard, Pierre Arnold
 Bertschler, Frank L.
 Blee, Harry H.
 Boess, Murray
 Born, Christian Eckhardt
 Bradley, S. S.
 Brattain, Paul H.
 Breckinridge, Henry
 Briner, E. R.
 Brinsmade, C. L.
 Brittin, Col. L. H.
 Brock, J. D.
 Brown, D. L.
 Brown, Fred L.
 Brownell, Dr. E. Garnsey
 Brukner, Clayton J.
 Brush, Mrs. Geo. De Forest
 Burden, William A. M.
 Bush, Charles T.
 Cabot, Godfrey L.
 Calendar, Sue-Louise
 Callan, J. Lansing
 Castle, B. F.
 Cautley, John R.
 Chace, Mason S.
 Chamberlin, Col. Clarence
 Chambers, Reed M.
 Chandler, Col. De F.
 Charlesworth, H. P.
 Chatfield, Charles H.
 Chevalier, John B.
 Clark, Col. V. E.
 Colby, C. B.
 Colman, Walter A.
 Colvin, C. H.
 Cowdin, J. Cheever
 Crane, Henry M.
 Cuthell, Chester W.
 Damon, R. S.
 Daniels, Leonard B.
 Davidson, W. F.
 Davies, Charles E.
 De Arce, L. Ponton
 Denton, Edward A.
 Depew, Richard H., Jr.
 Dey, William H.
 Dodge, Martin
 Dolan, D. J.
 Dunning, W. H.
 Earhart, Amelia
 Eggert, H. F.
 Eubank, J. A.
 Fairchild, Sherman M.
 Fales, Herbert G.
 Finch, Harry L.
 Findley, Earl N.
 Fokker, Anthony H. G.
 Forbes, William A.
 Foster, John M.
 Frank, Alfred
 Frisoli, J. D.
 Gardner, L. D.
 Gassaway, Gerrich
 Gott, E. N.
 Gund, Henry, Jr.
 Gunther-Mohr, J. J.
 Haldeman, George W.
 Hall, Randolph F.
 Hanks, Stedman
 Hanscom, Clarence D.
 Hanshue, Harris M.
 Harney, Miss Laura B.
 Haskins, George W.
 Haverstock, A. D., M. D.
 Heermance, Andrew H.
 Henderson, Cliff
 Henderson, Paul
 Henderson, Phil.
 Hinshaw, Hainer
 Hobbie, A. D.
 Hodges, Duncan
 Hoey, Robert F.
 Holcombe, T. G.
 Horner, Leonard S.
 Hotchkiss, Henry G.
 Houston, George H.
 Howson, Charles T.
 Hoyt, Richard F.
 James, Oliver B.
 Johnson, P. G.
 Johnson, R. L.
 Jones, Bradley
 Jordan, Franklin
 Jouett, Col. John H.
 Kettering, C. E.
 Klemm, Prof. Alexander
 Knack, Frederick
 Knerr, Horace C.
 Koerner, Grace E.
 Kohler, John B.
 Larsen, L. K.
 Lawrance, Charles L.
 Lawson, I. N., Jr.
 Lee, Norman C.
 Leeds, William B.
 Leh, John
 Lewis, Orme
 Light, Dr. Richard U.
 Litchfield, P. W.
 Loening, Albert P.
 Loening, Grover
 Love, Francis H.
 MacCracken, Wm. P.
 Manning, L. B.
 Martin, George E.
 Matthews, C. H., Jr.
 McCarthy, J. F.
 McCormac, Dr. Edward
 McDonald, H. Stewart, Jr.
 McGrath, Miss Marie T.
 McLean, Philip S.
 McNear, Cyril
 Meade, George J.
 Metzger, William E.
 Miller, Elam
 Mock, Richard M.
 Morrissey, Rev. John R.
 Newbold, George
 Newell, Joseph S.
 Newton, Millard H.
 Noorduyn, R. B. C.
 Norton, Bradford, Jr.
 Norton, Elijah H.
 O'Ryan, Maj. Gen. John F.
 Page, Haven B.
 Parker, J. Brooks B.
 Patchin, Philip H.
 Patchin, R. H.

Pfenninger, Herman T.
Philbin, Stephen H.
Pitcairn, Harold F.
Potter, Charles W.

Reed, Albert S.
Regan, L. E.
Rentschler, F. B.
Richardson, Capt. H. C.
Ripley, J. P.
Robertson, G. H.
Robinson, Ernest
Rodey, Pearce C.
Rogers, D. W.
Ronan, John A.
Root, W. Russell
Rosenbaum, Richard
Rothholz, Miss Meta
Russell, Frank H.
Russell, Roy E.

Sabor, Russell
Saltus, R. Sanford
Sampter, Herbert C.
Saunders, W. L., 2nd
Scheffey, Frank L.
Schmidlapp, Lawrence M.
Scholle, Howard A.
Schonhardt, J. C.

Scott, William Keith
Seidell, L. R.
Seversky, Alexander P. de
Sheaffer, D. M.
Short, C. W.
Sickenger, W. H.
Sidles, Harry
Sikorsky, I. I.
Smith, J. Story
Spaulding, Roland H.
Spencer, Lorillard
Spencer, Robert L.
Steffen, Michael F.
Stinson, Karl W.
Stone, Fowler P., Jr.
Stout, W. B.
Stuart, Clinton W.
Sullivan, John Dwight

Tait, Harry T.
Tarbox, J. P.
Taylor, James B.
Teetor, Ralph R.
Thomas, W. P.
Tibbetts, Milton
Tidmarsh, G. P.
Timpson, L. G. Morris
Trippe, J. T.
Tuttle, Horace Burt

Uppercu, I. M.
Upson, Ralph
Van Alstyne, W. B., Jr.
Vaughan, G. W.
Villiers, Amherst
Vincent, J. G.

Wall, William Guy
Walz, Edward J.
Ward, Roswell H.
Waters, Everett O.
Webb, J. Griswold
Webster, James McB.
Welch, Raymond W.
Wheat, George S.
White, Ernest M.
Wilford, E. Burke
Willebrandt, Mabel Walker
Williams, H. L.
Witter, J. D.
Wood, Edward S., Jr.
Wood, J. D.
Woodman, Duncan A.
Wright, Orville
Wright, Theodore P.
Wyatt, Benjamin F.
Wynne, John
Young, W. C.

AERONAUTICAL EXPOSITIONS CORPORATION



22 East Fortieth Street, New York

Officers

Charles L. Lawrance.....	President
Clayton J. Brukner.....	Vice-President
John R. Cautley.....	Secretary
J. A. B. Smith.....	Treasurer
Luther K. Bell.....	General Manager
Frank J. Walsh.....	Assistant Treasurer, Assistant Secretary

Directors

J. S. Allard	W. B. Hurlburt
E. T. Asplundh	P. G. Johnson
Luther K. Bell	Charles L. Lawrance
C. J. Brukner	L. B. Manning
John R. Cautley	Charles Marcus
F. G. Coburn	Thomas A. Morgan
Sherman M. Fairchild	J. M. Schoonmaker, Jr.
George S. Wheat	

AERONAUTICAL MAGAZINES OF THE UNITED STATES

Aero Digest, 515 Madison Avenue, New York, N. Y.
Aeronautical Engineering, American Society of Mechanical Engineers, 29 West 39th Street, New York, N. Y.
Air Law Review, Washington Square East, New York, N. Y.
Air Transportation, 22 East 40th Street, New York, N. Y.
Aircraft Age, 113 East 31st Street, Kansas City, Mo.
Aviation, 330 West 42nd Street, New York, N. Y.
Aviation Engineering, 19 East 47th Street, New York, N. Y.
Journal of Air Law, 357 East Chicago Avenue, Chicago, Ill.
National Aeronautic Magazine, National Aeronautic Association, Du Pont Circle, Washington, D. C.
Official Aviation Guide of the Airways, 608 S. Dearborn Street, Chicago, Ill.

Popular Aviation, 608 S. Dearborn Street, Chicago, Ill.
Sky Lines, 612 N. Michigan Avenue, Chicago, Ill.
Southern Aviation, Grant Building, Atlanta, Ga.
Sportsman Pilot, 515 Madison Avenue, New York, N. Y.
U. S. Air Services, Transportation Building, Washington, D. C.
Universal Model Airplane News, 125 West 45th Street, New York, N. Y.
Western Flying, 145 S. Spring Street, Los Angeles, Calif.

FOREIGN AERONAUTICAL MAGAZINES

ARGENTINA

Aero, Bartolome Mitre 2748, Buenos Aires.
Aviacion, Calle Jose Pedro Varela, 3762, Buenos Aires.
Bulletin del Aero-Club Argentino, Avenida de Mayo, 646, Buenos Aires.

AUSTRALIA

Aircraft, 62 Flinders Street, Melbourne, C. I.
Flying, Box 2597 NN, G.P.O., Sydney, N.S.W.

AUSTRIA

Flug, Traugasse 11, Vienna III.
Oesterreichische Touring Zeitung, Peregringasse 2, Vienna IX.

BELGIUM

Bulletin Mensuel d'Informations du Service de Propagande Aéronautique, 90 Rue de la Loi, Brussels.
Bulletin du Service Technique de l'Aéronautique, 34 Chaussée de Waterloo, Rhode St. Genèse, Brussels.
Conquête de l'Air, 16 Rue de Namur, Brussels.
L'Éche des Ailes, 8 Rue des Beggards, Antwerp.

CANADA

Canadian Aviation, 143 University Avenue, Toronto 2.

CHILE

Auto y Turismo, Casilla 3319, Santiago.
Chile Aereo, Casilla 913, Santiago.

CUBA

Aviacion, Neptuno 2, Havana.

CZECHOSLOVAKIA

Flugwesen, Konviktská 22, Prague I.
Letec, Dejvice, Palác Bajkal, Prague XIX.
Letectvi, Celetná 13, Prague.
Le Mois Aéronautique Tchécoslovaque, Celetná 13, Prague.

DENMARK

Flyv, Snorresgade 7, Copenhagen.

FINLAND

Aero, Ilmavoimien Esikunta, Helsingfors.

FRANCE

L'Aéroauto, 139 Quai d'Orsay, Paris.
L'Aéronautique, 55 Quai des Grands-Augustins, Paris.
L'Aérophile, 6 Rue Galilée, Paris.
Les Ailes, 65 Faubourg Poissonnière, Paris 9e.
L'Air, 2 Rue Blanche, Paris.
Bulletin de la Chambre Syndicale des Industries Aéronautiques, 4 Rue Galilée, Paris 16e.

Bulletin de la Fédération Aéronautique Internationale, 6 Rue Galilée, Paris.
Bulletin de la Navigation Aérienne, 7 Rue St. Lazare, Paris 9e.
Bulletin Technique du Bureau Veritas, 31 Rue d'Offremont, Paris.
Le Document Aéronautique, 1 bis, Place de l'Alma, Paris.
Droit Aérien, 4 bis Rue des Ecoles, Paris 5e.
L'Indicateur Aérien, 2 Rue Blanche, Paris 9e.
Le Journal de L'Aviation Française, 80 Rue Taitbout, Paris.
La Revue Aéronautique de France, 18 Avenue Victor Emmanuel III, Paris.
Revue de l'Aéronautique Militaire, 55 Quai des Grands-Augustins, Paris.
Revue des Forces Aériennes, 55 Quai des Grands-Augustins, Paris.
Revue Juridique Internationale de la Locomotion Aérienne, 4 Rue Tronchet, Paris.
La Vie Aérienne et Sportive, 80 Rue Taitbout, Paris.
La Vie Maritime et Aérienne, 24 Rue des Ardennes, Paris.

GERMANY

Der Adler, Seyfferstrasse 66, Stuttgart.
Deutsche Luftfahrt, Augustastrasse 18, Berlin-Lichterfelde.
Flugsport, Bahnhofplatz 8, Frankfurt.
Luft Und Kraftfahrt, Michaelkirchplatz 1, Berlin SO. 16.
Die Luftreise, Neue Kantstrasse 13, Berlin-Charlottenburg.
Luftschau, Shell-Haus, Berlin W. 10.
Luftwacht, Shell-Haus, Berlin, W. 10.
Mitteldeutsche Luftfahrt, Laasenerstrasse 29, Gera.
Nachrichten für Luftfahrer, Wilhelmstr. 86, Berlin W. 8.
Revue der Luftfahrt, Belle-Alliancestrasse 100, Berlin S. W. 61.
Verkehrstechnische Woche, Stallschreiberstr. 35, Berlin S. 14.
Zeitschrift für das Gesamte Luftrecht, Gentinerstr. 38, Berlin W. 18.
Zeitschrift für Flugtechnik und Motorluftschiffahrt, Glückstr. 8, Munich.

GREAT BRITAIN

Aeroplane, 175 Piccadilly, London W. 1.
Air and Airways, 6 Norfolk St., London W. C. 2.
Aircraft Engineering, 6 Norfolk St., London W. C. 2.
Flight, 36 Great Queen Street, Kingsway, London W. C. 2.
Journal of the Royal Aeronautical Society, 7 Albemarle Street, London W. 1.
Royal Air Force Quarterly, 2 Amen Corner, London E. C. 4.
Sailplane and Glider, 44a Dover St., London W. 1.

HUNGARY

Aviatika, Lónyay-utca 17, Budapest IX.

ITALY

Aeronautica, Via Gesu 6, Milan.
L'Aerolecnica, Via delle Coppelle 35, Rome.
L'Ala d'Italia, Via Settala 22, Milan.
L'Aviazione, Corso Umberto 112, Rome.
Bollettino dell'Aviazione Civile e del Traffico Aereo, Ministero dell'Aeronautica, Rome.
Il Diritto Aeronautico, Piazza Foro Traiano 1, Rome.
Noliziaro Tecnico di Aeronautica, Ministero dell'Aeronautica, Rome.
Rassegna Marittima Aeronautica, Via Ulisse Seni 5, Rome.
Rivista Aeronautica, Ministero dell'Aeronautica, Rome.
Rivista di Diritto Aeronautico, Via dell'Anima 45, Rome.
Studi di Diritto Aeronautico, Via del Tritone 201, Rome.
La Via Azzura, 28 Via Cuma, Naples.
Le Vie dell'Aria, Viale Università, Rome.

JAPAN

Hiko, 7 Sakuradahongo-cho, Shiba-Ku, Tokio.
Koku-Jidai, 2, Sakurada-Fushimi-cho, Shiba-ku, Tokio.

MEXICO

Aviacion, San Juan de Lotran 6, Mexico City.
El Piloto, Tiajuana B. C.

NETHERLANDS

Het Vliegfeld, Singel 464, Amsterdam.

NETHERLANDS EAST INDIES

Luchtvaart, G. Kolff & Co., Batavia, Java.

PERU

El Motor, 694 Lampa, Lima.

POLAND

Lot Polski, Długa 50, Warsaw.
Lotnik, Fr. Ratajczaka 21g, Posen.
Przeglad Lotniczy, Warsaw.

PORTUGAL

Revista do Ar, Largo do Calhariz 29, Lisbon

ROUMANIA

Aripa, Str. Clemenceau 10, Bucharest.
Aeronautica, 128 Calea Grivitei, Bucharest.

RUSSIA

Aviatsia i Chimia, Ilinka, Khrustalny per, Moscow.
Chronika Vosdushnogo Dela, Union of Osoaviakhim Societies, Moscow.
Samolet, Union of Osoaviakhim Societies, Moscow.

SPAIN

Boletin Oficial de la Direccion General de Aeronautica Civil, Calle de la Magdalena, 12, Madrid.
Espana Automovil y Aeronautica, Plaza de Fermin Galan, Madrid.
Icaro, Calle de Alberto Bosch, 3, Madrid.
Revista de Aeronautica, Ministerio de la Guerra, Madrid.

SWEDEN

Flygning, Birgerjarlsgatan, 6, Stockholm.

SWITZERLAND

Aero Revue, Bergstrasse 22, Oerlikon-Zurich.

URUGUAY

Revista del Centro Militar y Naval, Convencion 1332, Montevideo.

AVIATION EDITORS OF PRINCIPAL AMERICAN NEWSPAPERS AND PRESS ASSOCIATIONS

The following directory of aviation editors of principal newspapers and press associations listed by states and supplying additional information as to whether the paper has a daily, weekly or Sunday aviation column or page and has chartered airplanes to speed the getting of news or photographs during 1932 was prepared by the Aeronautical Chamber of Commerce of America with the cooperation of the newspapers in a survey made especially for "The Aircraft Year Book."

Name of Newspaper	Name of Aviation Editor	Aviation Column or Page	Chartered Planes in 1932
Alabama			
<i>Birmingham News and Age-Herald</i>	Ralph Hurst	Sundays	Yes
<i>Mobile Press</i>	C. D. Nowlin		
Arizona			
<i>Tucson Citizen</i>	H. G. Wilson		
Arkansas			
<i>Little Rock Gazette</i>	Leighton McKinney	Daily	
<i>Pine Bluff Graphic</i>	Edgar B. Chesnutt		
California			
<i>Los Angeles Examiner</i>	Charles B. Dawson	Semi-weekly	Yes
<i>Los Angeles Evening Express</i>	Terrel de Lapp	Sundays	Yes
<i>Los Angeles Times</i>	Sherman Carash	Daily	Yes
<i>Oakland Tribune</i>	Hamilton Hintz		
<i>Sacramento Bee</i>	Leonard J. Hintz		
<i>Sacramento Union</i>			

<i>Name of Newspaper</i>	<i>Name of Aviation Editor</i>	<i>Aviation Column or Page</i>	<i>Chartered Planes in 1932</i>
<i>San Diego Sun</i>	Max Miller	Weekly	
<i>San Francisco Chronicle</i>	Harry Hall	Sundays	
<i>San Francisco Examiner</i>	Frank Lyman		
<i>San Jose Mercury Herald</i>	Robert E. Ryan	Sundays	
Colorado			
<i>Denver Post</i>	James Irwin		
<i>Pueblo Star Journal</i>	Herbert A. Foster		
Connecticut			
<i>Hartford Times</i>	Burton E. Moore, Jr.	Weekly	
District of Columbia			
<i>Washington Daily News</i>	Robert Ball	Daily	No
<i>Washington Evening Star</i>	Joseph S. Edgerton	Sunday	Yes
Florida			
<i>Jacksonville Journal</i>	May McCormick	Daily	Yes
Georgia			
<i>Atlanta Georgian American</i>	Cody Laird		Yes
Illinois			
<i>Bloomington Pantagraph</i>	Maxwell E. H. Pyle		Own Plane
<i>Chicago Daily News</i>	Charles Schwarz	Weekly	Yes
<i>Chicago Daily Times</i>			Yes
<i>Chicago Evening Post</i>	George Robbins	Weekly	No
<i>Chicago Herald Examiner</i>	William Westlake	Semi-weekly	No
<i>Chicago Journal of Commerce</i>	Milton Van Slyck		Yes
<i>Chicago Tribune</i>	Hugh Sexton		No
<i>Illinois State Register</i>	James Graham	Sundays	
<i>Moline Daily Dispatch</i>	Vernon Hagelin		Yes
<i>Peoria Evening Star</i>	Mabel Bonjean	Daily	Yes
<i>Rockford Register Republic</i>	Allen O. Brophy	Irregular	Yes
Indiana			
<i>Fort Wayne Journal-Gazette</i>	Harold K. Milks	Weekly	Yes
<i>Fort Wayne News-Sentinel</i>	Robert Schott	Daily	Own Plane
<i>Indianapolis Star</i>	Walter F. Morse	Daily	
<i>Indianapolis Times</i>	L. B. Nussbaum	Daily	Yes
Iowa			
<i>Cedar Rapids Gazette</i>	Naomi Doebel		No
<i>Council Bluff's Nonpareil</i>	Harry Mauk, Jr.	Weekly	Yes
<i>Davenport Democrat</i>	Ralph W. Cram		Own Plane
<i>Des Moines Register and Tribune</i>	Charles W. Gatschet		Own Planes
<i>Mason City Globe Gazette</i>	W. Earl Hall		
<i>Ottumwa Daily Courier</i>	Tom Keefe, Jr.		
<i>Sioux City Tribune</i>	Henry B. Cooper		Yes
Kansas			
<i>Topeka Capital</i>	Harry Elliott		
<i>Topeka State Journal</i>	Walter M. Markley		
<i>Wichita Beacon</i>	James Woods		Yes
<i>Wichita Eagle</i>	Will Cunningham	Daily	Own Plane
Kentucky			
<i>Lexington Leader</i>	Frederick Jackson	No	No
<i>Paducah Sun-Democrat</i>	Miss Sidney Cook		Yes
Louisiana			
<i>New Orleans Times Picayune</i>	George Healy, Jr.		
Maine			
<i>Portland Evening News</i>	Harold L. Cail		
<i>Portland Press Herald</i>	Charles Cutter	Weekly	No

<i>Name of Newspaper</i>	<i>Name of Aviation Editor</i>	<i>Aviation Column or Page</i>	<i>Chartered Planes in 1932</i>
Maryland			
<i>Baltimore Sun</i>	George H. Engeman	Weekly	
Massachusetts			
<i>Boston Christian Science Monitor</i>	Volney D. Hurd	Weekly	
<i>Boston Evening Transcript</i>	Franklin E. Jordan	Weekly	Yes
<i>Boston News Bureau</i>	George W. Mason, Jr.	Daily	No
<i>Pittsfield Berkshire Eagle</i>	Arthur J. C. Underhill	None	
<i>Springfield Republican</i>	Ted Giddings	Weekly	
	George Pelletier	Weekly	
Michigan			
<i>Detroit Free Press</i>	James V. Piersol	Sundays	Yes
<i>Detroit News</i>	Robert Ross	Weekly	Own Planes
<i>Detroit Times</i>	H. Wendel Spencer	Weekly	
<i>Grand Rapids Press</i>	J. M. Hill	Weekly	
<i>Lansing State Journal</i>		Weekly	
<i>Pontiac Daily Press</i>		Weekly	
<i>Port Huron Times Herald</i>	Frederic G. Telmos	Weekly	
Minnesota			
<i>Duluth News-Tribune</i>	P. A. Coulter	Weekly	
<i>Minneapolis Star</i>	James Sutherland	Daily	
<i>St. Paul Dispatch-Pioneer Press</i>		Sundays	
Missouri			
<i>Kansas City Star</i>	R. S. Knowlson	Weekly	
<i>St. Louis Post-Dispatch</i>	T. P. Wagner	Weekly	Yes
<i>St. Louis Times</i>	Frank Sullivan		
Nebraska			
<i>Nebraska State Journal (Lincoln)</i>	Richard O. Bennett		Yes
New Jersey			
<i>Jersey City Jersey Journal</i>	William J. Shannon		
<i>Newark Evening News</i>	Roger Garis	Saturdays	
New Mexico			
<i>Albuquerque Journal</i>	Deacon Arledge		
<i>N. M. State Tribune (Albuquerque)</i>	George Fitzpatrick	Irregular	No
New York			
<i>Brookly Eagle</i>	Thomas Steutel		Yes
<i>Brooklyn Times Union</i>	Charles E. Hastings	Weekly	Yes
<i>Buffalo News</i>	Charles A. Michie	Daily	
<i>Buffalo Times</i>	Gordon Davis	Sundays	
<i>New York Herald Tribune</i>	Wayne Weishaar	Weekly	
<i>New York Sun</i>	Sherman B. Altick	Semi-weekly	
<i>New York Times</i>	R. M. Cleveland	Sundays	Yes
<i>New York Wall Street Journal</i>	L. D. Lyman		
<i>New York World-Telegram</i>	Walter H. Neff		
<i>Utica Observer Dispatch</i>	C. B. Allen	Sundays	
North Carolina			
<i>Charlotte Observer</i>		Irregular	Yes
North Dakota			
<i>Jamestown Sun</i>	Evelyn Nicholas Burleson	Daily	
Ohio			
<i>Akron Beacon Journal</i>	Harold J. Taylor	Daily	
<i>Akron Times-Press</i>	William Shenkel	Daily	
<i>Cincinnati Enquirer</i>	James T. Golden, Jr.	Weekly	
<i>Cincinnati Post</i>			
<i>Cincinnati Times-Star</i>	Fred Burns	Weekly	
<i>Cleveland Plain Dealer</i>	James D. Hartshorne		

<i>Name of Newspaper</i>	<i>Name of Aviation Editor</i>	<i>Aviation Column or Page</i>	<i>Chartered Planes in 1932</i> Own Plane Yes
<i>Cleveland News</i>	Julian Griffin		
<i>Cleveland Press</i>	Francis G. Lauffer		
<i>Columbus Citizen</i>	Charles Williams	Dally	
<i>Columbus Dispatch</i>	Harold W. Carlisle		
<i>Columbus Ohio State Journal</i>	R. E. Roberts		
<i>Toledo Blade</i>			
Oklahoma			
<i>Oklahoma City Daily Oklahoman</i>	B. Turner		Yes
<i>Oklahoma City Times</i>	George E. Lipe	Weekly	Yes
<i>Tulsa Tribune</i>	Virgil Curry		
<i>Tulsa World</i>	Lee Erhard		Yes
Oregon			
<i>Portland Morning Oregonian</i>	Webster E. Jones	Weekly	Yes
Pennsylvania			
<i>Pittsburgh Press</i>	Charles P. Johnson	Weekly	Yes
<i>Erie Dispatch Herald</i>	Barbara Hawley	Daily	
<i>Erie Times</i>	Earl Harvey	Daily	Yes
<i>Philadelphia Public Ledger</i>			
Tennessee			
<i>Chattanooga Times</i>	Brainard Cheney	Weekly	Yes
<i>Nashville Banner</i>	Jack Munroe	Weekly	Yes
<i>Nashville Tennessean</i>			
Texas			
<i>Dallas Times Herald</i>	Gerald Forbes		
<i>El Paso Herald and Times</i>	Hal Rush		
<i>Fort Worth Star-Telegram</i>	James Calvert	Daily	Yes
<i>Galveston News</i>	Frank E. Walker	Weekly	
<i>San Antonio Evening News</i>	William F. Salathe	Weekly	
<i>San Antonio Express</i>	C. Blair MacPhail	Weekly	Yes
<i>San Antonio Light</i>	R. G. Fraim		
Utah			
<i>Ogden Standard-Examiner</i>	Will H. Bowman		Yes
Virginia			
<i>Richmond News Leader</i>	W. L. Oliver		
Washington			
<i>Seattle Post-Intelligencer</i>	A. H. Norton		Yes
<i>Spokane Daily Chronicle</i>	Ellsworth C. French		Yes
<i>Spokane Press</i>	Wafford Conrad		
Wisconsin			
<i>Madison State Journal</i>	Don Anderson		
<i>Milwaukee Journal</i>	C. F. Butcher	Sundays	
<i>Milwaukee Leader</i>	Burdette Kirkham		
Press Associations			
The Associated Press 383 Madison Ave., New York	None		Yes
International News Service New York, N. Y.	None		Yes
National Enterprise Association Cleveland, Ohio	James F. Donahue	Weekly	Yes
News Syndicate-Science Service Washington, D. C.	J. W. Young		
Non-Aviation Magazines			
<i>Scientific American</i>	Alexander Klemin		
<i>Sportsman</i>	Daniel Rochford		
<i>Time</i>	A. L. Furth		

AIRPORTS AND AIRPORT MANAGERS IN THE UNITED STATES

January 1, 1933

The following is a selected list of leading American airports and their managers compiled by the Airport Section of the Aeronautical Chamber of Commerce of America, Inc., especially for The Aircraft Year Book for 1933. All airports listed have sufficient landing area for normal landings and take-offs. No intermediate or auxiliary fields are included. Municipally owned fields are indicated by (m) preceding the name of the airport.

<i>Location</i>	<i>Name of Port</i>	<i>Manager</i>
ALABAMA		
Bay Minette.....	Hand Airport.....	
Birmingham.....	(m) Birmingham Airport.....	Steadham Acker
Birmingham.....	Messer Field.....	
Brewton.....	(m) Miller's Field.....	
Mobile.....	(m) Bates Field.....	O. N. Barney
Montgomery.....	(m) Montgomery Airport.....	Lion G. Mason
Selma.....	(m) Legion Field.....	
ARIZONA		
Ajo.....	(m) Ajo Airport.....	W. R. Devison
Chandler.....	(m) Chandler Airport.....	Marg. K. Stewart
Douglas.....	(m) Douglas International Airport.....	L. Pyfe Peters
Flagstaff.....	(m) Koch Field.....	Ross Sampson
Globe.....	(m) Midland Airport.....	
Grand Canyon.....	South Rim Airport.....	
Jerome.....	Clemenceau Airport.....	
Kingman.....	Port Kingman.....	
Marana.....	(m) Marana Landing Field.....	
Phoenix.....	Sky Harbor Airport.....	
Prescott.....	(m) Ernest A. Love Airport.....	S. A. Spear
St. Johns.....	(m) Harry A. Saunders Airport.....	
Springerville.....	(m) Springerville Landing Field.....	Melvin Brown
Tucson.....	(m) Davis Monthan Field.....	R. L. Andrick, S.S.
Willcox.....	(m) Willcox Airport.....	
Winslow.....	(m) TWA Airport.....	C. W. Helm, C.A.C.
Yuma.....	(m) Fly Field.....	Yuma C. of C.
ARKANSAS		
Conway.....	Conway Airport.....	
Ft. Smith.....	Alexander Airport.....	
Little Rock.....	(m) Little Rock Airport.....	
Monticello.....	(m) Monticello Airport.....	Frank Horsfall
Paragould.....	(m) Paragould Airport.....	
Pine Bluff.....	(m) Toney Field.....	Kenneth Garrett
Texarkana.....	(m) Texarkana Airport.....	J. B. Newbauer, Op.
CALIFORNIA		
Alameda.....	Alameda Airport.....	L. R. Dooley
	San Francisco Bay Airdrome.....	R. U. St. John
Alhambra.....	Pasadena-Alhambra Airdrome.....	
Avalon.....	Catalina Seaplane Airport.....	
Bakersfield.....	Kern County Airport.....	H. B. Griffis, Supt.
Barstow.....	(m) 20-30 Airport.....	Russell E. Riley
Berkeley.....	(m) Berkeley Airport.....	
Blythe.....	(m) Blythe Airport.....	
Brawley.....	(m) Brawley Airport.....	M. H. Carberry
Burbank.....	United Airport.....	Fred Denslow
Calexico.....	(m) Calexico Airport.....	Roy E. Saddler
Chico.....	Chico Airport.....	
Colusa.....	(m) Colusa Airport.....	
Compton.....	Compton Airport.....	
Delano.....	(m) Delano-Kern County Airport.....	
Desert Center (Mecca).....	Desert Center Airport.....	
Elsinore.....	(m) Lake Elsinore Airport.....	O. W. Graham
Eureka.....	Murray Field.....	
Fillmore.....	Fillmore Airport.....	
Fresno.....	(m) Fresno Chandler Airport.....	Geo. T. Johnson, Supt.
Fullerton.....	(m) Fullerton Airport.....	Claude L. Long
Glendale.....	Grand Central Air Terminal.....	Maj. C. C. Moseley
Grass Valley.....	Gillmore Flying Field.....	
Hanford.....	(m) Hanford Airport.....	A. C. Hanford
Imperial.....	(m) Imperial County Airport.....	Chas. M. Sproule
Lancaster.....	Lancaster Airport.....	
Long Beach.....	(m) Daugherty Field.....	Wm. J. Putnam, Supt.
Los Angeles.....	Dycer Airport.....	Edw. A. Dycer
Los Angeles.....	(m) Los Angeles Airport.....	R. B. Barnitz, Dir.
Los Angeles.....	Metropolitan Airport.....	N. R. Wells, Jr.

AERONAUTICAL DIRECTORY AND TRADE INDEX 459

<i>Location</i>	<i>Name of Port</i>	<i>Manager</i>
Los Banos.....(m)	Los Banos Airport.....	
Marysville.....(m)	Cheim Airport.....	F. H. Bartlett
Merced.....(m)	Merced Airport.....	Geo. G. Vought
Modesto.....(m)	Bud Coffee Field.....	F. J. Rossi, C.E.
Mojave.....	Modesto Airport.....	
Monrovia.....	Kern County Airport.....	
Montague.....(m)	Foothill Flying Field.....	
Needles.....(m)	Montague Airport.....	Chas. C. Shock
Oakland (Grove St. Pier)(m)	Needles Airport.....	George Morden
Ontario.....(m)	Oakland Airport.....	G. B. Hegardt
Palo Alto.....	Ontario Airport.....	
Paso Robles.....(m)	Goddard Airport.....	
Petaluma.....	Paso Robles Airport.....	
Porterville.....	Petaluma Airport.....	
Red Bluff.....(m)	Porterville Airport.....	Maj. LeRoy Miller
Redding.....(m)	Bidwell Field.....	Raines F. Griffin
Redwood City.....	Benton Field.....	L. D. Sarvis, C.A.C.
Riverside.....	Sanders Field.....	
Sacramento.....(m)	Riverside Airport.....	Roman C. Warren
Salinas.....(m)	Sacramento Airport.....	Donald B. Smith
San Bernardino.....	American Legion Airport.....	
San Diego.....(m)	Big Bear City Airport.....	Cal. Peter Pan Woodland Club
San Francisco.....(m)	Lindbergh Field.....	John Van Horn, Supt.
San Jose.....(m)	San Francisco Airport.....	B. M. Doolin
San Luis Obispo.....	San Jose Airport.....	
San Mateo.....	Clark Field.....	
Santa Ana (P.O. Box 986).....	Curtiss-Wright Airport.....	Capt. F. M. Bartlett
Santa Barbara.....	Eddie Martin's Airport.....	Floyd R. Martin
Santa Cruz.....(m)	Goleta Airport.....	
Santa Maria.....	Santa Barbara Airport.....	
Santa Monica.....(m)	Santa Cruz Airport.....	
Santa Paulo.....	Hancock Field.....	Rufus J. Pilcher
Santa Rosa.....(m)	Clover Field.....	
Sebastopol.....(m)	Santa Paulo Airport.....	L. E. Newton
Stockton.....	Santa Rosa Municipal Airport.....	L. C. Cnoplus
Stockton.....(m)	Sebastopol Airport.....	
Strathmore.....(m)	Oranges Brothers Airport.....	
Taft.....(m)	Stockton Airport.....	Henry Nordwick
Vallejo.....(m)	Strathmore Airport.....	C. W. Bouldin
Visalia.....(m)	Taft Airport.....	
Watsonville.....	Knight Field.....	
Willows.....(m)	Visalia Airport.....	L. E. Crowder
Yreka.....(m)	Watsonville Airport.....	
	Willows Airport.....	Irving L. Eddy
	Yreka Airport.....	
COLORADO		
Colorado Springs.....	Alexander Airport.....	Pikes Peak Air Com. Inc.
Colorado Springs (R. 1, Box 7).....(m)	Colorado Springs Airport.....	Max Piele
Denver.....	Curtiss-Wright Field.....	
Denver, 32d & Ulster St.(m)	Denver Airport.....	W. F. Wunderlich
Durango.....(m)	Durango Airport.....	
Ft. Collins.....	Ft. Collins Airport.....	
Grand Junction.....(m)	Grand Junction Airport.....	D. B. Bullock
Greeley.....(m)	Greeley Airport.....	
Holyoke.....(m)	Holyoke Airport.....	
Montrose.....(m)	Montrose Airport.....	
Pueblo.....(m)	Pueblo Airport.....	D. W. Tuff
CONNECTICUT		
Bridgeport.....	Bridgeport Airport.....	F. D. Moller
Danbury.....(m)	Danbury Airport.....	Henry Taylor
Groton.....(m)	Trumbull Field.....	
Hartford.....(m)	Brainard Field.....	Herbert H. Mills
Hartford.....	Rentschler Field.....	Bernard Whalen
Meriden.....(m)	Meriden Airport.....	E. L. Markham
New Haven.....(m)	New Haven Airport.....	
Wallingford.....(m)	Wallingford Airport.....	
DELAWARE		
New Castle.....	Bellanca Field.....	Dela. Flying Service
Wilmington.....	Buck Airport.....	
Wilmington.....	Dupont Field.....	
DISTRICT OF COLUMBIA		
Washington (S. Wash., Va., Box 101).....	Washington-Hoover Airport.....	C. E. Fauntleroy

AIRCRAFT YEAR BOOK

<i>Location</i>	<i>Name of Port</i>	<i>Manager</i>
FLORIDA		
Arcadia.....	Seward Airport.....	
Auburndale..... (m)	Auburndale Airport.....	
Bradenton..... (m)	Wallace Field.....	Harry L. Land, Mgr.
Clearwater..... (m)	Springtime Airport.....	Tropical Airways, Inc.
Daytona Beach..... (m)	Daytona Beach Airport.....	A. C. Banks
Ft. Lauderdale..... (m)	Merle Fogg Airport.....	
Ft. Myers..... (m)	Ft. Myers Airport.....	
Jacksonville..... (m)	Jacksonville Airport.....	J. R. Griffiths, Mgr.
Key West.....	Meacham Airport.....	
Lakeland..... (m)	Haldeman-Elder Field.....	
Miami.....	All-American Airport.....	
Miami.....	Curtiss-Wright Seaplane Base.....	
Miami.....	Dinner Key, Seaplane Base.....	Pan American Airways,
Miami..... (m)	Miami Airport.....	Aviation Dept., Miami
Miami.....	Pan American Airport.....	
Ocala..... (m)	Taylor Field.....	
Orlando..... (m)	Orlando Airport.....	Lt. E. C. Nilson
St. Augustine..... (m)	St. Augustine Airport.....	
St. Petersburg..... (m)	Albert Whitted Airport.....	J. B. Meares
St. Petersburg.....	Grand Central Airport.....	
Sanford..... (m)	Sanford Airport.....	
Sarasota..... (m)	Sarasota Airport.....	Dr. J. R. Scully, G.P.W.
Tallahassee..... (m)	Dale Mabry Field.....	Wm. R. Gault, C.M.
Tampa..... (m)	Drew Field.....	H. D. DeNegre
Vero Beach..... (m)	Vero Beach Airport.....	
West Palm Beach..... (m)	Currie Seaplane Base.....	
West Palm Beach.....	Belvedere Airport.....	
GEORGIA		
Albany..... (m)	Albany Field.....	
Athens..... (m)	Epps Field.....	Benn Epps, Mgr.
Atlanta..... (m)	Atlanta Airport.....	J. H. Gray, Mgr.
Augusta..... (m)	Daniel Field.....	Fred L. Dorset
Brunswick..... (m)	Redfern Field.....	
Cedartown.....	Adamson Field.....	C. Adamson, Jr. Mgr.
Columbus..... (m)	Columbus Airport.....	H. B. Crawford, C.M.
Douglas..... (m)	State College Airport.....	J. M. Thrash, Pres.
Macon..... (m)	Miller Field.....	R. J. Litteen
Moultrie..... (m)	Clark Field.....	
Rome..... (m)	Rome Airport.....	Rome Airport Association
Savannah..... (m)	Savannah Airport.....	
Thomasville..... (m)	Thomasville Airport.....	H. Wimpy
Valdosta..... (m)	Valdosta Airport.....	P. W. Robertson, Chrm.
Waycross..... (m)	Ware County Airport.....	
IDAHO		
Boise..... (m)	Boise Airport.....	Ivan Nelson, Mgr.
Burley..... (m)	Burley Airport.....	
Cascade..... (m)	Cascade Airport.....	
Idaho Falls..... (m)	Idaho Falls Airport.....	
Kellogg..... (m)	Shoshone County Airport.....	
Pocatello..... (m)	McDougall Field.....	E. L. Anderson, Mgr.
Twin Falls..... (m)	Twin Falls Airport.....	L. A. Dean
ILLINOIS		
Aurora.....	Midwest Airways Airport.....	J. H. Livingston, Mgr.
Bloomington.....	Bloomington Airport.....	
Champaign.....	Chamber of Commerce Airport.....	Wm. L. Snowden
Chicago.....	Aero Club Field.....	
Chicago, 5932 S. Cicero Ave..... (m)	Chicago Airport.....	John Allen Casey
Chicago (Glenview).....	Curtiss-Reynolds Airport.....	R. J. Hall
Chicago (Des Plaines).....	Pal-Waukee Airport.....	Duncan Hodges
Danville..... (m)	Chamber of Commerce Airport.....	
Decatur.....	National Airways System Airport.....	
East St. Louis.....	Curtiss-Steinberg Airport.....	C. Ray Wassell
East St. Louis.....	Parks Airport.....	Oliver L. Parks
Elgin..... (m)	Elgin Airport.....	Herbert Byrne.....
Elmhurst.....	Greer Lake St. Airport.....	
Galesburg.....	Galesburg Airport.....	
Jacksonville..... (m)	Jacksonville Airport.....	
Joliet..... (m)	Joliet Municipal Airport.....	Harry B. Ohlhauer
Joliet.....	Joliet Airport.....	
Kewanee..... (m)	Kewanee Airport.....	
Lansing.....	Ford Airport.....	
LaSalle.....	LaSalle-Peru Airport.....	
Lombard.....	Lombard Airport.....	
Marion.....	Marion Airport.....	

AERONAUTICAL DIRECTORY AND TRADE INDEX 461

Location	Name of Port	Manager
Moline.....	Moline Airport.....	Bernard Sewerkrup
Monmouth.....	Monmouth Airport.....	G. Craig
Peoria.....	Mt. Hawley Airport.....	Alex Varney
Quincy.....	Monroe Airport.....	Lester E. Webener
Quincy.....	Quincy Airport.....	
Rockford.....	Machesney Airport.....	F. E. Machesney
Springfield.....	Commercial Air Port.....	Craig Isabel, Mgr.
St. Elmo.....	Smith Aviation Field.....	Reginald Pattinson
Sterling..... (m)	Sterling Airport.....	E. P. Jacoby, Mgr.
Waterman..... (m)	De Kalb County Airport.....	
West Chicago.....	Air Activities Airport.....	
INDIANA		
Angola.....	Tri-State Airport.....	
Auburn.....	Cord Airport.....	
Elkhart.....	Aero Service Airport.....	
Evansville..... (m)	Evansville Airport.....	W. R. Genot
Ft. Wayne..... (m)	Baer Field.....	E. W. Campbell
Ft. Wayne..... (m)	Means Airport.....	Capt. C. F. Corrish
Frankfort..... (m)	Frankfort Airport.....	
Gary.....	Gary Airport.....	
Indianapolis.....	Capitol Airport.....	
Indianapolis, R. R. 18, Box 300R.....	Hoosier Airport.....	Bob Shank, Mgr.
Indianapolis..... (m)	Indianapolis Airport.....	Maj. C. E. Cox, Jr.
Kokomo..... (m)	Kokomo Airport.....	Mike Murphy
LaFayette.....	Shambaugh Airport.....	
Madison.....	Crozier Airport.....	
Michigan City.....	Michigan City Airport.....	
Muncie.....	Muncie Airport.....	
Richmond.....	Richmond Airport.....	Claud Berry
South Bend..... (m)	South Bend Airport.....	Glen W. Borror
Terre Haute..... (m)	Dresser Field.....	J. H. Haxton
Vincennes.....	O'Neal Field.....	
Wabash, 485 W. Canal St.....	Rettig Airport.....	Geo. O. Rettig
IOWA		
Ames.....	Ames Airport.....	
Boone.....	Boone Airport.....	
Burlington..... (m)	Burlington Airport.....	A. J. Hartman
Cedar Rapids.....	Cedar Rapids Airport.....	
Centerville..... (m)	Centerville Airport.....	V. C. Price
Clarinda.....	Ray Schenck Airport.....	
Columbus Junction.....	Pine Brothers Airport.....	
Council Bluffs..... (m)	Council Bluffs Airport.....	
Davenport.....	Cram Field.....	L. M. Pedigo, Mgr.
Denison.....	Chamberlin Field.....	
Des Moines..... (m)	Des Moines Airport.....	E. R. Ahlberg, Mgr.
Dewitt.....	Dewitt Airport.....	
Estherville..... (m)	Estherville Airport.....	
Ft. Dodge.....	Ft. Dodge Airport.....	C. L. Sherwood
Iowa City..... (m)	Iowa City Airport.....	Jack Curtis
Milford.....	Donaldson Bros. Aviation Field.....	
Monticello.....	Monticello Airport.....	
Muscatine..... (m)	Muscatine Airport.....	S. G. Stine, Mgr.
Sioux City.....	Rickenbacker Airport.....	A. S. Hanford, Jr.
Waterloo.....	Waterloo Airport.....	A. B. Livingston, Mgr.
KANSAS		
Beloit.....	Barker's Airport.....	
Bird City..... (m)	Bird City Airport.....	
Caney.....	Truskett Airport.....	
Chanute, Box 514..... (m)	Chanute Airport.....	Vern Carstens, Mgr.
Clay Center..... (m)	Clay Center Airport.....	
Coffeyville..... (m)	Coffeyville Airport.....	Lynn Berentz
Concordia..... (m)	Concordia Airport.....	
Dodge City.....	McCoy Airport.....	
Garden City..... (m)	Garden City Airport.....	Charles B. Eggen
Goodland..... (m)	Goodland Airport.....	Vernon Dorney
Great Bend..... (m)	Great Bend Airport.....	Board of Commissioners
Hutchinson..... (m)	Hutchinson Airport.....	
Kansas City.....	Fairfax Airport.....	R. F. Craig
Larned..... (m)	Larned Airport.....	Sec. C. of C.
Lawrence..... (m)	Lawrence Airport.....	
Newton..... (m)	Newton Airport.....	K. L. Brode
Norton..... (m)	Norton Airport.....	
Pittsburg.....	Pittsburg Airport.....	L. M. Atkinson, Pres.
Pratt.....	Pratt Airport.....	F. F. Swinson

AIRCRAFT YEAR BOOK

<i>Location</i>	<i>Name of Port</i>	<i>Manager</i>
Salina.....(m)	Salina Airport.....	
Spirit Lake.....(m)	Spirit Lake Airport.....	
Topeka.....	Topeka Airport.....	
Wichita.....	Central Ave. Flying Field.....	
Wichita.....	Kellogg Airport.....	
Wichita.....(m)	Wichita Airport.....	H. L. Mellor, Supt.
KENTUCKY		
Corbin.....(m)	Corbin Airport.....	
Louisville.....(m)	Bowman Field.....	Lt. Col. H. W. Rogers, Supt.
Newport.....	Boyers Airport.....	
Owensboro.....	Sheehan Field.....	
Paducah.....	Paducah Airport.....	
Williamstown.....	Williamstown Airport.....	
LOUISIANA		
Alexandria.....(m)	Alexandria Airport.....	
Baton Rouge.....(m)	Baton Rouge Airport.....	
Baton Rouge.....	Ronaldson Airport.....	
Eunice.....(m)	Legion Airport.....	
Hammond.....(m)	Port Hammond Airport.....	
Monroe.....(m)	Selman Field.....	C. E. Woolman
New Orleans (P.O. Box 783).....	Menefee Airport.....	W. J. Fry
New Orleans.....(m)	New Orleans Airport.....	Geo. A. Hero, Jr.
New Orleans.....	Weddell-Williams Airport.....	
Patterson.....	Patterson Airport.....	
Shreveport.....(m)	Shreveport Airport.....	
MAINE		
Bangor.....	Godfrey Field.....	E. Godfrey
Farmington.....	Farmington Airport.....	
W. Scarborough.....	Portland Airport.....	S. B. Chandler
Portland.....	Stroudwater Field.....	Portland Flying Service
Presque Isle.....	Presque Isle Airport.....	M. S. W. Dingwall
Rockland, Box 280.....	Curtiss-Wright Airport.....	W. H. Winicapaw
Sanford.....	Sanford Airport.....	
Skowhegan.....	Whittemore Field.....	
Waterville.....	Waterville Airport.....	
MARYLAND		
Baltimore.....	Martin Airport.....	
Baltimore.....	Rutherford Field.....	
Baltimore (Dundalk).....(m)	Logan Field.....	L. M. Rawlins, Jr.
Baltimore.....	Curtiss-Wright Airport.....	W. D. Tipton, Mgr.
Cumberland.....	Cumberland Airport.....	
Easton.....	Tred Avon Airport.....	
Hagerstown.....	Hagerstown Airport.....	
Rockville.....	Congressional Airport.....	
MASSACHUSETTS		
Athol.....	Orange & Athol Airport.....	
Beverly.....(m)	Beverly Airport.....	
Boston.....(m)	Boston Airport.....	Albert L. Edson
Boston (North Quincy).....	Dennison Airport.....	H. E. Martin
Brockton.....	Brockton Airport.....	
Falmouth.....(m)	Falmouth Airport.....	
Fitchburg.....	Fitchburg-Leominster Airport.....	
Framingham.....	Framingham Airport.....	
Gardner.....	Gardner Airport.....	
Haverhill.....	Haverhill Airport.....	
Hyannis.....	Hyannis Airport.....	Alton B. Sherman
Lowell.....	Lowell Airport.....	
Marlboro.....	Marlboro Airport.....	
Natick.....	Natick Wellesley Airport.....	
Northampton.....	LaFleur Airport.....	
Pittsfield.....	Pittsfield Airport.....	
Revere.....	Muller Field.....	Al Zewink
Springfield.....	Bowles-Agawam Airport.....	Capt. Harry J. Hermann
Springfield.....	Springfield Airport.....	Edmund Fischer
Taunton.....	King Field.....	
Westfield-Holyoke.....(m)	Barnes Airport.....	Chas. O'Connor
MICHIGAN		
Alma.....	Sharrar Airport.....	
Ann Arbor.....(m)	Ann Arbor Airport.....	D. E. Richardson
Baldwin.....(m)	Hulbertrest Airport.....	H. W. Davis, Mgr.
Battle Creek.....(m)	Kellogg Airport.....	Randolph Russell
Bay City.....(m)	James Clements Airport.....	Henry Dora

AERONAUTICAL DIRECTORY AND TRADE INDEX 463

<i>Location</i>	<i>Name of Port</i>	<i>Manager</i>
Caro..... (m)	Caro Airport.....	Glenn W. Owen
Cheboygan.....	Cheboygan County Airport.....	
Crystal Falls..... (m)	Crystal Falls Airport.....	
Detroit (Dearborn).....	Ford Airport.....	B. N. Russell
Detroit (400 City Hall)..... (m)	Detroit City Airport.....	Perry A. Fellows
Detroit.....	Wayne County Airport.....	
Flint.....	Bishop Airport.....	
Grand Rapids.....	Grand Rapids-Plainfield Airport.....	
Grand Rapids.....	Grand Rapids Airport.....	Thomas Walsh
Harbor Springs..... (m)	Emmet County Airport.....	Norman W. Wells
Hartford.....	Leach Aero Service Field.....	
Houghton.....	Isle Royale Sands Airport.....	
Howell..... (m)	Howell Airport.....	
Ironwood..... (m)	Gogebic County Airport.....	George Koronski
Jackson..... (m)	Reynolds Fields.....	Ross Beckner
Kalamazoo..... (m)	Lindbergh Field.....	C. T. Tolpo
Lansing..... (m)	Capitol City Airport.....	Fostor Airways
Manistique..... (m)	Schoolcraft County Airport.....	
Marysville..... (m)	Marysville Airport.....	Marysville Improv. Co.
Menominee..... (m)	Menominee County Airport.....	S. Justema, Supt.
Midland..... (m)	Midland Airport.....	Merle Newkirk
Monroe.....	Monroe Airways Airport.....	
Muskegon..... (m)	Muskegon County Airport.....	James Kukla
Newberry..... (m)	Luce County Airport.....	S. C. Sleepe
Owosso.....	Owosso Airport.....	
Plymouth.....	Triangle Flying Service Field.....	
Pontiac..... (m)	Pontiac Airport.....	G. D. Kennedy, Dir.
Saginaw..... (m)	Junior Board of Commerce Field.....	Jos. E. Behse
Sault Ste. Marie..... (m)	Sault Ste. Marie Airport.....	H. A. Sherman
Traverse City..... (m)	Traverse City Airport.....	Don Clotheir
Wayne.....	Detroit Wayne Ind. Airport.....	E. J. Smith
Ypsilanti R. R. No. 4..	Ypsilanti Airport.....	M. E. Oliphant, Mgr.
MINNESOTA		
Coleraine..... (m)	Coleraine Airport.....	C. M. Murphy
Duluth..... (m)	Williamson-Johnson Airport.....	Harry T. Peterson
Fergus Falls.....	Fergus Falls Airport.....	Gustav O. Imm
Hibbing..... (m)	Hibbing Airport.....	
Jackson..... (m)	Jackson Airport.....	
Mankato.....	Mankato Airport.....	L. J. Sohler
Minneapolis..... (m)	Minneapolis Municipal Airport.....	L. D. Hammond, Dir.
Rochester.....	Rochester Airport.....	
St. Paul..... (m)	Holman Municipal Airport.....	F. J. Geng, Master
Virginia..... (m)	Virginia Airport.....	Clinton H. Sigel
MISSISSIPPI		
Clarksdale..... (m)	Clarksdale Airport.....	
Corinth.....	Corinth Airport.....	
Greenwood..... (m)	Greenwood Airport.....	L. D. Pepper, Jr.
Greenville..... (m)	Greenville Airport.....	T. White
Gulfport..... (m)	Gulfport.....	
Hattiesburg..... (m)	Hattiesburg Airport.....	
Jackson..... (m)	Jackson Airport.....	
Laurel..... (m)	Laurel Airport.....	
Meridian..... (m)	Meridian Airport.....	
MISSOURI		
Bucklin.....	Vanosdel Field.....	
Carthage.....	Carrothers Airport.....	
Columbia.....	Allton Airport.....	
Jefferson City..... (m)	Jefferson City Airport.....	
Kansas City..... (m)	Kansas City Airport.....	Roy C. Farrell
Kansas City.....	Old Richards Field.....	
Marshall.....	Nicholas-Beazley Field.....	R. B. Nicholas
Springfield..... (m)	Springfield Airport.....	Carl McClure
St. James.....	St. James Airport.....	
St. Joseph..... (m)	Rosecrans Field.....	H. C. Bradfield
St. Louis (Robertson)..... (m)	Lambert-St. Louis Airport.....	O. R. Parks
MONTANA		
Belgrade..... (m)	Belgrade Airport.....	E. A. Stiefel, C. A. Comm.
Billings..... (m)	Billings Airport.....	Dick Logan
Butte..... (m)	Butte Airport.....	J. K. Heslet
Dillon.....	Dillon Airport.....	Fred Woodside
Glasgow..... (m)	Glasgow Airport.....	
Great Falls..... (m)	Great Falls Airport.....	
Havre..... (m)	Havre Airport.....	
Helena..... (m)	Helena Airport.....	Fred B. Sheriff, Chrm.
Kalispell..... (m)	Kalispell Aviation Park.....	C. E. Trekell, Clerk

AIRCRAFT YEAR BOOK

<i>Location</i>	<i>Name of Port</i>	<i>Manager</i>
Miles City..... (m)	Miles City Airport.....	
Missoula..... (m)	Missoula Airport.....	
NEBRASKA		
Alliance..... (m)	Alliance Airport.....	
Columbus.....	Columbus Airport.....	
Grand Island..... (m)	Grand Island Airport.....	Stover Deats, Mgr.
Holdrege..... (m)	Holdrege Airport.....	
Lincoln.....	Arrow Airport.....	
Lincoln..... (m)	Lindbergh Field.....	D. L. Erickson, C.E.
Lincoln.....	Union Airport.....	
McCook..... (m)	Chamber of Commerce Airport.....	
Norfolk.....	Norfolk Airport.....	
North Platte..... (m)	North Platte Airport.....	C. H. Sluder
Omaha..... (m)	Omaha Airport.....	Jay Dudley, Mgr.
Scottsbluff..... (m)	Schafer Field.....	
NEVADA		
Caliente..... (m)	American Legion Airport.....	Willard W. Smith
Elko..... (m)	Keddie Field.....	Ted Johnson
Las Vegas.....	Las Vegas Airport.....	
Reno..... (m)	Blanchfield Airport.....	Robert E. Overman
Reno.....	Hubbard Field.....	
NEW HAMPSHIRE		
Claremont..... (m)	Claremont Airport.....	Claremont Aero. Service
Concord..... (m)	Concord Airport.....	Horton Chandler, Mgr.
Keene.....	Keene Airport.....	
Manchester..... (m)	Manchester Airport.....	
Newport..... (m)	Albert N. Parlin Field.....	Benj F. Burr
Twin Mountain.....	Twin Mountain Airport.....	
NEW JERSEY		
Atlantic City..... (m)	Atlantic City Airport.....	H. B. Baldwin, Supt.
Caldwell.....	Essex Airport (Curtiss-Wright Field).....	Frank LeMan
Camden.....	Central Airport.....	J. W. Markeim
Cape May..... (m)	Cape May Airport.....	
Hasbrouck Heights.....	Teterboro Airport.....	G. D. Dardis
Lakehurst.....	Lakehurst Airport.....	
Newark..... (m)	Newark Metropolitan Airport.....	R. Aldworth
New Brunswick.....	Hadley Airport.....	Frank LeMan
Paterson.....	Murchio Field.....	
Red Bank.....	Red Bank Airport.....	J. F. Casey, Pres.
Trenton.....	Trenton Airport.....	
Trenton..... (m)	Mercer Airport.....	William S. Borden, Dir.
NEW MEXICO		
Albuquerque.....	Albuquerque Airport.....	D. E. Dalby
Albuquerque.....	T. & W. A. Airport.....	
Carlsbad..... (m)	Carlsbad Airport.....	
Farmington..... (m)	Farmington Airport.....	
Roswell..... (m)	Roswell Airport.....	
Santa Fe.....	Santa Fe Airport.....	
Silver City..... (m)	Whitehill Airport.....	Sam W. Agee
Socorro..... (m)	Socorro Airport.....	W. E. West, Sec. S. B. M. C.
NEW YORK		
Albany..... (m)	Albany Airport.....	J. F. Fitzgerald, Jr.
Armonk.....	Westchester Airport.....	W. P. Lawless
Binghamton.....	Binghamton Airport.....	
Binghamton.....	Bennett Field.....	C. W. Woodworth
Buffalo.....	Becker Airport.....	E. J. Becker
Buffalo..... (m)	Buffalo Airport.....	N. E. Duffy
Cortland..... (m)	Cortland County Airport.....	H. R. Mell
Dansville..... (m)	Dansville Airport.....	L. E. Pickard
Elmira (Box 451).....	Elmira Airport.....	Francis H. Parks
Endicott.....	Endicott Airport.....	
Farmingdale.....	American Airport.....	M. Gould Beard
Flushing.....	Flushing-New York Airport.....	W. W. Lewis
Glens Falls..... (m)	Floyd Bennett Field.....	
Gloversville.....	Gloversville Airport.....	
Hammondsport.....	Mercury Field.....	J. F. Meade
Hemlock.....	Hemlock Airport.....	Dr. Harold Nott
Islip.....	Islip Airport.....	A. I. Theis
Ithaca..... (m)	Ithaca Airport.....	
Jamestown.....	Jamestown.....	
Johnstown.....	Ace-Vaughn Field.....	
LeRoy.....	Donald Woodward Airport.....	Capt. Russell Holderman

AERONAUTICAL DIRECTORY AND TRADE INDEX 465

<i>Location</i>	<i>Name of Port</i>	<i>Manager</i>
Massapequa.....(m)	Fitzmaurice Field.....	Daniel Hogan
Mineola.....	Roosevelt Field.....	George W. Orr, Pres.
Montgomery.....	Tri-States Airways Airport.....	
New York City.....(m)	Floyd Bennett Field, Brooklyn....	J. N. Kelly
New York City (Green- ridge).....	Donovan Hughes Airport.....	
New York City (Jack- son Heights).....	Glenn Curtiss Airport.....	Bruce Johnson
Niagara Falls.....(m)	Niagara Falls Airport.....	P. N. Pattison
Norwich.....	Norwich Airport.....	Warren Eaton, Pres.
Oneonta.....	Keys Field.....	
Pittsford.....	Brizee Aviation Field.....	R. G. Hottman
Poughkeepsie.....	Poughkeepsie Airport.....	John M. Miller
Rochester.....(m)	Rochester Airport.....	Howard M. Shafer
Rochester.....	Commercial Airport.....	
Saratoga Springs.....	Saratoga Springs Airport.....	
Schenectady.....	Schenectady Airport.....	J. H. Alrutz
Syracuse.....	Empire Airport.....	
Syracuse.....(m)	Syracuse Airport.....	R. L. Kincaid
Troy.....	Troy Airport.....	
Utica.....(m)	Utica Airport.....	Reginald J. Heath
Valley Stream.....	Curtiss-Wright Airport.....	Bruce Johnson
Watertown.....(m)	Watertown Airport.....	F. H. Taylor
Wellsville.....(m)	Wellsville Aviation Club Field.....	
Westport.....(m)	Westport Airport.....	
NORTH CAROLINA		
Asheville.....(m)	Asheville-Hendersonville Airport.....	
Charlotte, Box 735.....	Charlotte Airport.....	J. R. Farrow
Fayetteville.....	Fayetteville Airport.....	
Greensboro.....(m)	Lindley Field.....	Henry W. Rafus
High Point.....	Chas. Kenner Flying Service Airport.....	
Kinston.....(m)	Kinston Airport.....	
Marion.....(m)	Francis Marion Field.....	W. F. Shifflett
New Bern.....(m)	New Bern Airport.....	
N. Wilkesboro.....	N. Wilkesboro Airport.....	
Pinehurst.....(m)	Knollwood Airport.....	Lloyd O. Yost
Raleigh.....	Curtiss-Wright Airport.....	Elmer A. Myers
Rockingham.....	Fox's Rockingham Airport.....	V. Ratliff
Rocky Mount.....	Eagle Airport.....	J. D. Winstead, Owner
Salisbury.....(m)	Salisbury Airport.....	
Wilmington.....	Wilmington Airport.....	
NORTH DAKOTA		
Bismarck.....(m)	Bismarck Airport.....	M. H. Atkinson, G.M.
Devils Lake.....(m)	Devils Lake Airport.....	
Dickinson.....(m)	Dickinson Municipal Airport.....	
Fargo.....(m)	Hector Field.....	Titus Richards
Grand Forks.....(m)	Grand Forks Airport.....	E. L. Lium, Act. Mgr.
Hettinger.....(m)	Hettinger Airport.....	
Jamestown.....(m)	Jamestown Airport.....	C. A. Henderson, Sec.
Minot.....(m)	Port O Minot.....	C. O. Shupe
Pembina.....(m)	Pt. Pembina Airport.....	Mun. Airport Comm.
Towner.....	Jake's Airport.....	J. J. Bertram
Valley City.....(m)	Valley City Airport.....	C. E. Clarke
Williston.....(m)	Williston Airport.....	E. M. Canfield
OHIO		
Akron.....(m)	Akron Airport.....	B. E. Fulton
Akron.....	Stow Field.....	N. C. Robbins
Alliance.....	Alliance Airport.....	
Ashland.....	Ashland Airport.....	
Ashtabula.....(m)	Ashtabula Airport.....	Lauretta M. Schimmoler
Bucyrus.....(m)	Port Bucyrus.....	
Canton.....	McKinley Airport.....	
Cincinnati.....(m)	Cincinnati Airport (Lunken Fld.)..	Albert B. Wunder, Supt.
Cincinnati.....	Watson Airport.....	
Cleveland.....(m)	Cleveland Airport.....	John Berry, Mgr.
Cleveland.....	Great Lakes Aircraft Corp. Fld.....	
Columbus.....	Clickenger Airport.....	
Columbus.....(m)	Port Columbus.....	Maj. Wm. F. Centner, Supt.
Coshocton.....	Coshocton Airport.....	Russell C. Jacobs
Dayton.....(m)	Dayton Municipal.....	
Dayton.....	East Dayton Airport.....	
Edison.....	Ireland Airport.....	
Findlay.....	Rummell Airport.....	Harry B. Rummell
Gallipolis.....(m)	Twin City Airport.....	Stanley B. Huntington, Mgr.
Lancaster.....(m)	Lancaster Airport.....	
Lorain.....	Port Mills Airport.....	W. W. Doty

<i>Location</i>	<i>Name of Port</i>	<i>Manager</i>
Madison.....	Madison-on-the-Lake Airport.....	
Marietta..... (m)	Ohio Valley Airport.....	Chris Matthews
Marion..... (m)	Marion Airport.....	
Middletown.....	Middletown Airport.....	Geo. J. Wedekind
Montpelier.....	Montpelier Airport.....	
Sandusky.....	Parker Field.....	
Sandusky.....	Quinn Airport.....	
Springfield..... (m)	Springfield Mun. Airport.....	W. B. Little
Toledo.....	Transcontinental Airport.....	C. J. Fenton
Willoughby.....	Lake County Airport.....	Harry R. Playford
Willoughby.....	Euclid Ave. Airport.....	
Youngstown.....	Bernard Airport.....	
Youngstown..... (m)	Youngstown Airport.....	C. S. Hanson
OKLAHOMA		
Ada.....	Ada Airport.....	Lt. Paul Hinds
Bartlesville.....	Phillips Aviation Field.....	Wm. Parker
Blackwell..... (m)	Blackwell Airport.....	C. A. Bradfield
Bristow.....	Bristow Airport.....	G. C. Kittelsen
Chickasha..... (m)	Chickasha Airport.....	Paul Rider
Claremore..... (m)	Will Rogers Airport.....	
Duncan..... (m)	Halliburton Field.....	J. H. Bender, C.M.
Durant..... (m)	Eaker Airport.....	
Elk City..... (m)	Elk City Airport.....	Walter D. Mauk
El Reno..... (m)	Reno Airport.....	H. M. Woods, C.A.C.
Enid..... (m)	Enid Air Park.....	Capt. Hugh Askew
Mangum..... (m)	Ponder Field.....	Ray Shiffett
McAlester.....	Claud Eures Airport.....	
Miami..... (m)	Miami Airport.....	H. G. Freehauf
Muskogee..... (m)	Hatbox Field.....	L. L. Rupert
Oklahoma City.....	Curtiss-Wright Airport.....	Aubrey Keif
Oklahoma City..... (m)	Oklahoma City Airport.....	William E. Fletcher
Pauls Valley.....	Pauls Valley Airport.....	Earl Witten
Perry..... (m)	Perry Air Park.....	
Ponca City..... (m)	Ponca City Airport.....	T. D. Harris.
Stillwater..... (m)	Stillwater Airport.....	L. M. McGoodwin
Tulsa.....	McIntyre Airport.....	D. A. McIntyre
Tulsa, Box 3156..... (m)	Tulsa Airport.....	C. W. Short, Jr.
Waynoka.....	Waynoka Airport.....	
Woodward..... (m)	Woodward Airport.....	
OREGON		
Albany..... (m)	Albany Airport.....	F. E. Bloom
Ashland..... (m)	Ashland Airport.....	
Baker..... (m)	American Legion Airport.....	
Beaverton.....	Watts Airport.....	
Corvallis.....	Corvallis Airport.....	H. E. Walter, Pres.
Corvallis.....	Lyndon Airport.....	
Eastside..... (m)	Coos Bay Airport.....	
Eugene, Box 328..... (m)	Eugene Airport.....	H. H. Hobi
Grants Pass..... (m)	Josephine County Airport.....	Josephine County A.C.
Klamath Falls..... (m)	Klamath Falls Airport.....	C. Golden
Lakeview..... (m)	Lakeview Airport.....	Harry Ballard
Medford, Box 1016..... (m)	Medford Airport.....	Wm. S. Clarkson
North Bend..... (m)	North Bend Airport.....	Frank L. Black
Pendleton..... (m)	Pendleton Airport.....	
Portland..... (m)	Portland Airport.....	James H. Polhemus
Portland.....	Christoferson Airport.....	
Portland.....	Rankin Airport.....	Tex Rankin
Roseburg..... (m)	Roseburg Airport.....	A. J. Geddes
Salem..... (m)	Salem Airport.....	Lee Eyerly
Springfield..... (m)	Springfield Airport.....	
PENNSYLVANIA		
Allentown.....	Allentown Airport.....	J. S. Christman
Altoona-Tyrone.....	Stultz Field.....	
Beaver Falls..... (m)	Beaver Falls Airport.....	
Berwick.....	Berwick Airport.....	
Bethlehem.....	Bethlehem Airport.....	Stanley W. Keck
Bradford.....	Harri Emery Airport.....	John J. Moore
Coatesville..... *	Coatesville Airport.....	
Dubois..... (m)	Dubois Airport.....	
Easton.....	Easton Airport.....	
Ebensburg.....	Keystone Airport.....	
Erie.....	Port Erie Airport.....	
Fairview.....	Erie County Airport.....	N. R. McCray
Gettysburg.....	Gettysburg Airport.....	M. S. Kleinfelter
Harrisburg.....	Harrisburg Airport.....	
Harrisburg.....	Susquehanna Airport.....	

<i>Location</i>	<i>Name of Port</i>	<i>Manager</i>
Indiana	Hamilton Field	
Johnsonburg..... (m)	Johnsonburg Legion Airport	
Jones Mills.....	Pike Run Airport	
Johnstown..... (m)	Johnstown Airport	J. H. Ritter
Kylertown.....	Ames Airport	
Lancaster.....	Lancaster Airport	
Latrobe.....	J. D. Hill Airport	
Leechburg.....	Leechburg Airport	
Lehighton.....	Lehighton Airport	
Meadville.....	Port Meadville Airport	
New Castle.....	Bradford Airport	
Nicholson.....	Mount View Airport	
Norristown.....	Patco Field	
Parkesburg.....	Robb Field	
Philadelphia..... (m)	Philadelphia Airport	LeRoy Hauser
Phila. (Willow Grove).....	Pitcairn Field	George E. Chambliss
Pittsburgh (Dravosburg).....	Curtiss-Bettis Airport	W. C. McConnell, Jr.
Pittsburgh..... (m)	Pittsburgh-Allegheny County Airport	C. W. Forcier
Pittsburgh.....	Pittsburgh-Butler Airport	
Reading.....	Whander Field	Carl A. Reber
Scranton.....	Scranton Airport	
Somerset.....	Rhoads Field	Alfred K. Young
Sunbury..... (m)	City of Sunbury Airport	
Towanda..... (m)	Towanda Legion Airport	
Waynesboro.....	Waynesboro Airport	
Wilkes-Barre.....	Wilkes-Barre Wyoming Valley Airport	Geo. S. Eckman
Williamsport.....	Williamsport Airport	T. H. Kinkade
York.....	York Airport	
RHODE ISLAND		
Newport.....	Newport Airport	
Pawtucket.....	What Cheer Airport	Joshua Crane, Jr.
Providence, Box 223.....	Providence Airport	W. M. Fletcher
Woonsocket.....	Woonsocket Airport	
SOUTH CAROLINA		
Anderson..... (m)	Anderson Airport	
Camden..... (m)	Woodward Aviation Field	
Charleston..... (m)	Charleston Airport	
Columbia..... (m)	Columbia Airport	
Florence..... (m)	Florence Airport	D. L. Husband
Greenville..... (m)	Greenville Airport	
Myrtle Beach.....	Myrtle Beach Airport	C. G. Brown
Rock Hill.....	Roddey Airport	
Spartanburg..... (m)	Spartanburg Airport	
SOUTH DAKOTA		
Aberdeen..... (m)	Aberdeen Airport	B. J. Coombs
Belle Fourche.....	Belle Fourche Airport	
Lemmon..... (m)	Lemmon Airport	C. of C.
Mobridge.....	Mobridge Flying Service Field	I. L. Hagen
Pierre..... (m)	Walter J. Smith Airport	City of Pierre
Rapid City.....	Rapid Air Lines Corporation Airport	
Sioux Falls.....	Renner Field	
Volga.....	Midway Airport	
Wagner..... (m)	Wagner Airport	C. W. Knight
Watertown.....	Watertown Airport	R. C. Hubbard
TENNESSEE		
Chattanooga.....	Brainerd Airport	
Chattanooga..... (m)	Chattanooga Airport	W. DeLand Dyke
Knoxville..... (m)	McGhee-Tyson Airport	
Memphis..... (m)	Memphis Airport	B. B. Holmes
Nashville..... (m)	McConnell Field	W. L. Hethcote
Nashville.....	Tennessee's Sky Harbor	O. T. Ridley
Union City..... (m)	Union City Airport	
TEXAS		
Abilene..... (m)	Abilene Air Terminal	
Albany..... (m)	Plane Haven Airport	J. P. Alexander
Amarillo.....	English Field	Harold W. English
Austin..... (m)	Robert Mueller Airport	
Austin.....	University Airport	
Beaumont..... (m)	Beaumont Airport	Frank L. Bertschler
Big Spring..... (m)	Big Spring Airport	Jesse Maxwell

<i>Location</i>	<i>Name of Port</i>	<i>Manager</i>
Bonham.....	(m) Jones Field.....	L. K. Crawford
Breckenridge.....	(m) Breckenridge Airport.....	C. H. Clark
Brownsville.....	(m) Brownsville Pan-American Airport.....	T. E. Gilmore
Corpus Christi.....	(m) Corpus Christi Airport.....	W. C. Maus
Corsicana.....	(m) Corsicana Airport.....	
Dallas.....	(m) Love Field.....	Preston Sneed
Del Rio.....	(m) Del Rio Airport.....	John Y. Long, Mayor
El Paso.....	Air Mail Field.....	
El Paso.....	(m) El Paso Airport.....	A. E. Johnson
Fort Worth.....	(m) Meacham Field.....	William G. Fuller
Grand Prairie.....	Curtiss-Wright Airport.....	
Harlingen.....	(m) Harlingen Airport.....	
Houston.....	(m) Houston Airport.....	C. P. Neuhaus
Houston.....	Houston Main Street Airport.....	
Kerrville.....	Louis Schreiner Airport.....	C. L. Mason, C.A. Comm.
Lubbock.....	(m) Lubbock Airport.....	Wm. C. Breedlove
McCamey.....	(m) McCamey Field.....	
Marfa.....	(m) Marfa Airport.....	
Marlin.....	(m) Chamber of Commerce Airport.....	
Marshall.....	(m) Marshall Airport.....	
Pecos.....	(m) Pecos Airport.....	Ralph Sparke
Port Arthur, Box 712.....	Texaco Airport.....	F. P. Dodge
Ranger, Box 902.....	(m) Ranger Airport.....	C. J. Moore, Mgr.
San Angelo.....	(m) San Angelo Airport.....	Autrey Monsey
San Antonio.....	(m) Winburn Field.....	J. Wayne Parks
Sherman.....	(m) Sherman Airport.....	
Sweetwater.....	(m) Sweetwater Municipal Airport.....	
Tyler.....	(m) Tyler Airport.....	
Waco.....	(m) Rich Field.....	J. C. Estes
Wichita Falls.....	(m) Kell Field.....	F. Armstrong
UTAH		
Ogden.....	(m) Ogden Airport.....	Harold R. Tripp
Salt Lake City.....	(m) Salt Lake Airport.....	Gilbert R. Rich
VERMONT		
Burlington.....	(m) Burlington Airport.....	S. E. Astles
Manchester.....	Equinox Airport.....	F. W. Orvis
Montpelier.....	Barre-Montpelier Airport.....	
Rutland.....	Rutland City Airport.....	
Springfield.....	(m) Hartness Airport.....	R. M. Wilcomb
White River Junction.....	Twin State Airport.....	A. W. Stone, Pres.
VIRGINIA		
Alexandria.....	Alexandria Airport.....	E. W. Robertson
Bristol.....	(m) Bristol Airport.....	Wm. F. Mitchell..
Charlottesville.....	Wood Field.....	
Danville.....	(m) Danville Airport.....	
Fredericksburg.....	(m) Shannon Field.....	
Hopewell.....	(m) Hopewell Airport.....	Lamar Johnson
Lynchburg, Box 782.....	(m) Preston Glenn Airport.....	R. D. Apperson
Norfolk.....	Norfolk Airport.....	
Port Richmond.....	(m) Thompson Field.....	Grosby Thompson, Mayor
Richmond.....	(m) Richard E. Byrd Flying Field.....	C. H. Schutte
Roanoke.....	(m) Roanoke Airport.....	Clayton Lemon
Waynesboro.....	Valley Airport.....	C. C. Loth
Williamsburg.....	(m) Williamsburg Airport.....	
Winchester.....	(m) Admiral Byrd Airport.....	Roy W. Richards
WASHINGTON		
Bellingham.....	Graham Field.....	R. C. Graham
Centralia.....	(m) Centralia Airport.....	T. R. Patton
Chehalis.....	(m) Chehalis Airport.....	A. C. St. John, Pres.
Ellensburg.....	Ellensburg Airport.....	L. G. Gehlen
Olympia.....	(m) Olympia Airport.....	E. N. Steele
Pasco.....	(m) Franklin County Airport.....	A. E. Wehe
Port Angeles.....	Port Angeles Air Transport Field.....	John Blum
Seattle.....	(m) Boeing Field.....	Maj. David G. Logg
Seattle.....	Renton (Bryn Mawr) Field.....	
Spokane.....	(m) Felts Field.....	Andrew J. Fabian
Tacoma.....	Mueller-Harkins Airport.....	
Tacoma.....	(m) Tacoma Field.....	J. D. Crichton
Vancouver.....	(m) Vancouver Airport.....	
Walla Walla.....	(m) Walla Walla Airport.....	
Wenatchee.....	Wenatchee Chamber of Commerce Airport.....	
White Bluffs.....	(m) White Bluffs Landing Field.....	
Yakima.....	(m) Yakima County Airport.....	County Comm.

<i>Location</i>	<i>Name of Port</i>	<i>Manager</i>
WEST VIRGINIA		
Bluefield.....	Bluefield Airport.....	
Charleston..... (m)	Wertz Field.....	
Huntington.....	Huntington Airport.....	
Wheeling.....	Scott Field.....	
White Sulphur Springs.....	Greenbrier Airport.....	L. R. Johnston
WISCONSIN		
Appleton.....	George A. Whiting Airport.....	E. West
Athletstane.....	Schaf Airport.....	
Eagle River.....	Keystone Park Airport.....	
Eagle River.....	McCullough-Otter Rapids Field.....	
Fond du Lac.....	Fond du Lac Airport.....	F. F. Manor
Green Bay..... (m)	Brown County Airport.....	
Janesville.....	Janesville County Airport.....	
Janesville.....	Janesville Airport.....	
Kohler..... (m)	Kohler Airport.....	Anton F. Brotz
La Crosse..... (m)	La Crosse Airport.....	Board Pub. Works
Land O'Lakes..... (m)	Land O'Lakes Airport.....	J. F. Handhos
Madison.....	Madison Airport.....	L. F. Schoelkopf
Madison.....	Royal Airport.....	Howard A. Marey
Manitowoc..... (m)	Manitowoc Airport.....	F. Shoblaska
Marshfield.....	Marshfield Airport.....	
Marshfield.....	Miners Airport.....	W. Miner
Milwaukee.....	Curtiss-Milwaukee Airport.....	R. J. Hall
Milwaukee..... (m)	Milwaukee County Airport.....	Maj. S. E. Piasecki
Mosinee.....	Mosinee Airport.....	
Oshkosh.....	Oshkosh Airport.....	R. A. Mensing, Jr.
Princeton..... (m)	Princeton Airport.....	G. V. Kelly
Rhineland..... (m)	Legion Field.....	Steve Shadbreck
Sheboygan..... (m)	Sheboygan Airport.....	Kohler-Sheboygan
Stevens Point.....	Stevens Point Airport.....	
Three Lakes..... (m)	Three Lakes Airport.....	H. L. Grandy
Washington Island.....	Washington Island Airport.....	Wm. Jess
Wausau.....	Alexander Airport.....	M. Johnson
Wisconsin Rapids.....	Nepco Tri-City Airport.....	Maj. L. G. Mulzer
WYOMING		
Casper..... (m)	Wardwell Field.....	R. Leferink
Cheyenne..... (m)	Cheyenne Airport.....	Boeing Air Transport
Cody..... (m)	Cody Airport.....	
Greybull.....	Greybull Airport.....	
Lander..... (m)	Lander Airport.....	Hugh D. Spangler
Parco.....	Parco Airport.....	
Rock Springs..... (m)	Rock Springs Airport.....	E. S. Maroney
Sheridan..... (m)	Sheridan Airport.....	Bob Garrett
Thermopolis..... (m)	Thermopolis Airport.....	

ALASKAN FLYING FIELDS

List Supplied by Aeronautics Branch, Department of Commerce

American Creek, American Creek Field, auxiliary	Flat, Flat Field, auxiliary
Anchorage, Anchorage Aviation Field, municipal and seaplane base	Fort Yukon, Fort Yukon Aviation Field, commercial
Bettles River, Bettles River Field, auxiliary	Golovin, Golovin Field, auxiliary
Bluff, Bluff Field, auxiliary	Healy, Healy Field, auxiliary
Cache Creek, Cache Creek Field, auxiliary	Kake, Kake Seaplane Base
Candle, Candle Field, auxiliary	Kantiahna District, Kantiahna Field, auxiliary
Cantwell, Cantwell Field, auxiliary	Kasilof, Kasilof Field, auxiliary
Cape Prince of Wales, Cape Prince of Wales Field, auxiliary	Kenai, Kenai Field, auxiliary
Chandalar, Chandalar Field, auxiliary	Ketchikan, Ketchikan Seaplane Airport, municipal
Chena Hot Springs, Chena Hot Springs Field, auxiliary	Kiwalik, Kiwalik Field, auxiliary
Chicken, Chicken Field, auxiliary	Kobuk, Kobuk Field, auxiliary (formerly Shungnak)
Chisana, Chisana Field, auxiliary	Kodiak, Kodiak Seaplane Base
Circle Hot Springs, Circle Hot Springs Field, auxiliary	Kotzebue, Kotzebue Field, auxiliary
Copper Center, Copper Center Field, auxiliary	Koyuk, Koyuk Field, auxiliary
Cordova, Cordova Field, auxiliary and seaplane base	Lake Minchumina, Lake Minchumina Field, auxiliary
Curry, Curry Field, auxiliary	Lake Spenard, Lake Spenard Field, auxiliary
Deering, Deering Field, auxiliary	Livengood, Livengood Field, auxiliary
Eagle, Eagle Field, auxiliary	Lost River, Lost River Field, auxiliary
Fairbanks, Weeks Field, commercial	Lower Tonsina, Lower Tonsina, Field, auxiliary

McCarthy, McCarthy Field, auxiliary
 McGrath, McGrath Field, auxiliary
 Manly Hot Springs, Manly Hot Springs Field, auxiliary
 Medfra, Medfra Field, auxiliary
 Moose Creek, Moose Creek Field, auxiliary
 Moses, Moses Field, auxiliary
 Nabesna, Nabesna Field, auxiliary
 Nenana, Nenana Field, auxiliary
 Ninilchik, Ninilchik Field, auxiliary
 Nome, Nome Field, auxiliary
 Nulato, Nulato Field, auxiliary
 Palmer Creek, Palmer Creek Field, auxiliary
 Petersburg, Petersburg Seaplane Airport, municipal
 Pilgrim Springs, Pilgrim Hot Springs Field, auxiliary
 Ruby, Ruby Field, auxiliary
 Seldovia, Seldovia Seaplane Base
 Seward, Seward Field, auxiliary

Skagway, Skagway Seaplane Airport, municipal
 Solomon, Solomon Field, auxiliary
 Susitna Station, Susitna Station Field, auxiliary
 Takotna, Takotna Field, auxiliary
 Tanana, Tanana Field, auxiliary
 Telida, Telida Field, auxiliary
 Teller, Teller Field, auxiliary
 Unalakleet, Unalakleet Field, auxiliary
 Upper Tonsina, Upper Tonsina Field, auxiliary
 Valdez, Valdez Field, auxiliary
 Valdez Creek, Valdez Creek Field, auxiliary
 Wasilla, Wasilla Field, auxiliary
 Willow Creek, Willow Creek Field, auxiliary
 Wiseman, Wiseman Field, auxiliary
 Wrangell, Wrangell Seaplane Airport, municipal

SEAPLANE ANCHORAGES IN THE UNITED STATES

List Supplied by Hydrographic Office, Navy Department, Washington, D. C.

CLASS I. ANCHORAGES WITH RAMP, ETC.

Atlantic Coast

Maine
 Bar Harbor (Hadley Point)
 Rockland

Massachusetts
 Gloucester (Coast Guard Air Station)
 Boston (Municipal Airport)
 Squantum (Naval Reserve Air Station)
 South Dartmouth (Round Hill Airport)

Rhode Island
 Newport (Gould Island Naval Torpedo Station)

Connecticut
 Bridgeport
 Groton
 New Haven

New York
 Brooklyn (Floyd Bennett Field)
 College Point, Long Island
 Croton-on-Hudson
 Lake George
 Port Washington, L. I.
 North Beach, L. I.
 New Dorp, Staten Island

New Jersey
 Atlantic City
 Cape May (Coast Guard Air Station)

Pennsylvania
 Bristol
 Philadelphia (Naval Aircraft Factory)
 Essington

Virginia
 Hampton (Langley Field)
 Hampton Roads (Naval Air Station)
 Hopewell
 Quantico (Marine Barracks)
 Dahlgren (Naval Proving Station)

Maryland
 Baltimore (2) (Middle River: Martin Airport), (Municipal Airport)

District of Columbia
 Washington (Naval Air Station, Anacostia)

North Carolina
 Beaufort

Florida
 West Palm Beach
 Miami (5)
 Key West (Naval Station)

Gulf Coast

Florida
 St. Petersburg
 Pensacola (Naval Air Station)

Louisiana
 New Orleans

Pacific Coast

California
 San Diego (Naval Air Station)
 Catalina Island
 Santa Monica
 Oakland (Oakland Municipal Airport)

Washington
 Seattle (5), (Sand Point Naval Reserve Air Station); (Renton Airport); (Elliott Bay); (Lake Union (2)).
 Port Townsend (Floating Hangar)

Great Lakes

Illinois
 Great Lakes (Naval Training Station)

Ohio
 Cleveland

Michigan
 Detroit
 Grosse Ile (Naval Reserve Aviation Base)
 Houghton

Wisconsin
 Milwaukee

West Indies

Bahama Islands—New Providence Island (Nassau)
 Cuba—Guantanamo (Hicacal Beach)
 Curacao—Willemstad

SEAPLANE ANCHORAGES OUTSIDE THE UNITED STATES

CLASS I. ANCHORAGES WITH RAMP, ETC.

Alaska

Anchorage (Floating Ramp)
 Juneau (Floating Hangar)
 Ketchikan (2) (Ramp and Floating Hangar)
 Petersburg

Canada

<p>British Columbia Naniamo Swanson Bay Vancouver (2) Victoria</p>	<p>New Brunswick Fredericton St. John</p>
---	--

Central America

<p>Canal Zone Coco Solo (U. S. Naval Air Station) France Field (U. S. Army Air Corps)</p>	<p>British Honduras Belize</p>
--	--

South America

<p>Brazil Ceara (Fortaleza) Natal Para Rio de Janeiro</p>	<p>British Guiana Georgetown</p>	<p>Chile</p>
<p>Dutch Guiana Paramaribo</p>	<p>Colombia Barranquilla Buenaventura</p>	

II. ANCHORAGES WITH ORDINARY HARBOR FACILITIES

Atlantic Coast

<p>Maine Calais *Eastport *Boothbay Bath *Portland</p>	<p>North Carolina Elizabeth City *Edenton Morehead City New Bern Wilmington</p>
<p>New Hampshire *Portsmouth</p>	<p>South Carolina *Georgetown *Charleston *Beaufort</p>
<p>Massachusetts Salem Provincetown West Barnstable *New Bedford Fall River Nantucket Edgartown</p>	<p>Georgia Savannah Bushwick</p>
<p>Rhode Island Providence</p>	<p>Florida *Fernandina *Jacksonville *St. Augustine *Daytona Beach *Titusville *Port Pierce</p>
<p>Connecticut *New London</p>	<p>New York *Port Jefferson, Long Island Amityville, Long Island Great Pond (Lake Montauk), L. I. Brooklyn</p>
<p>Maryland *Aberdeen Annapolis Baltimore</p>	<p>New Jersey *Keyport</p>

Gulf Coast

*Fort Myers	Florida	Pascagoula	Mississippi
*Sarasota		Biloxi	
*Tampa		Gulfpport	
*Cedar Keys		Bay St. Louis	
Panama City			Louisiana
Mobile	Alabama	Weeks	
		Texas	
		Port Arthur	
		Houston	
		Corpus Christi	
		Rockport	
		Point Isabel	

* Description of anchorage published in The Naval Air Pilot—East and Gulf Coasts of the United States. H. O. Publication 190.

U. S. AIR CORPS, WAR DEPARTMENT

Officers on Duty in Washington

F. Trabee Davison.....Assistant Secretary of War
 Maj. Gen. Benjamin D. Foulois.....Chief of the Air Corps
 Brig. Gen. Oscar Westover.....Assistant Chief of the Air Corps

Lieut. Colonels—F. M. Andrews; J. E. Chaney; J. E. Fickel; G. I. Jones (MC); J. D. Reardan.
 Majors—C. L. Beaven (MC); Wm. H. Crom; A. N. Duncan; W. H. Frank; A. H. Hobley;
 H. V. Hopkins; Davenport Johnson; J. W. Jones; R. M. Jones; W. G. Kilner; A. N.
 Krogstad; E. B. Lyon; Leslie MacDill; J. H. Pirie; R. Royce; J. H. Rudolph; C. W.
 Russell; W. F. Volandt; W. R. Weaver.

Captains—J. Beveridge, Jr.; A. W. Brock, Jr.; W. H. Brookley; I. Davies; I. H. Edwards;
 H. M. Elmendorf; M. G. Estabrook, Jr.; W. J. Flood; E. E. Hildreth; H. W. Holden;
 E. J. House; D. L. Hutchinson; G. C. Kenney; T. J. Koenig; A. B. McDaniel; P. J.
 Mathis; V. P. Meloy; M. F. Schneider; O. G. Trunk.

1st Lieutenants—E. Abbey; W. B. Hough; W. M. Lanagan; T. M. Lowe; G. C. McDonald;
 A. W. Martenstein; P. Martin; R. L. Owens; O. K. Robbins; M. Stenseth; L. P.
 Whitten.

Air Corps Posts

AKRON, OHIO—(Chief of the Air Corps) Balloon Production and Inspection. Procurement
 Section. District Office. P. O. Goodyear Tire & Rubber Co., Akron, Ohio.

ALBROOK FIELD—(P. C. Dept.) P. O. Quarry Heights, Canal Zone. 44th Obs. Sq.

BARKSDALE FIELD—(Fourth Corps Area) P. O. Shreveport, La. Air Corps Detachment.

BENNING, FT., GA.—Flight B, 16th Obs. Sq.

BIGGS FIELD—(Eighth Corps Area) P. O. Ft. Bliss, Texas. Intermediate Landing Field.

BOLLING FIELD—(Chief of the Air Corps) P. O. Anacostia, D. C. Air Corps Detach. Flying
 Field.

BOSTON AIRPORT—(First Corps Area) P. O. Boston, Mass. Air Corps Detach. Intermediate
 Landing Field. Reserve Flying. Reserve Airdrome.

BOWMAN FIELD—(Fifth Corps Area) P. O. Jeffersontown, Ky. Intermediate Landing Field.
 Reserve Airdrome.

BRAGG, FT.—(Fourth Corps Area) P. O. Ft. Bragg, N. C. 2nd Balloon Co. Flight C, 16th
 Obs. Sq.

BRISTOL, PA.—(Chief of the Air Corps) P. O. Bristol, Pa. Air Corps Representative Keystone
 Aircraft Corp.

BROOKS FIELD—(Eighth Corps Area) P. O. San Antonio, Texas. 12th Obs. Gp. Hq. 12th,
 22d, 88th Obs. Sqs. 1st Photo Section. 62d Service Sq. Border Patrol Station. Air-
 drome. Intermediate Landing Field.

BUFFALO, N. Y.—(Chief of the Air Corps) P. O. 65 Franklin St., Buffalo, N. Y. Procurement
 Planning Representative. Air Corps Representative. Curtiss Aeroplane & Motor Corp.
 Air Corps Procurement District.

BURGESS FIELD—(Chief of the Air Corps) P. O. Uniontown, Pa. Intermediate Landing Field.

CANDLER FIELD—(Fourth Corps Area) P. O. Atlanta, Ga. Reserve Airdrome.

CHANUTE FIELD—(Chief of the Air Corps) P. O. Rantoul, Ill. Technical School. School
 Troops.

CHAPMAN FIELD—(Fourth Corps Area) P. O. Miami, Fla. Temporary Machine Gun & Bomb-
 ing Range.

CHICAGO, ILL.—(Chief of the Air Corps) P. O. 1819 W. Pershing Road. Municipal Airport.
 Reserve Airdrome. Procurement Planning Representative. Air Corps Procurement
 District at 59 East Van Buren.

CLARK FIELD—(P. Dept.) P. O. Camp Stotsenburg, P. I. 3d Pursuit Sq.

CLARK, FT.—(Eighth Corps Area) P. O. Bracketville, Texas. Airdrome. Intermediate Land-
 ing Field.

CRISSEY FIELD—(Ninth Corps Area) P. O. Presidio of San Francisco, Calif. 91st Obs. Sq.
 15th Photo Section.

- CROCKETT, FT.—(Eighth Corps Area) P. O. Galveston, Texas. 3d Attack Wing Hq. Hq. 3d Attack Gp. 8th, 13th, 90th Attack Sqs. 60th Service Sq.
- CROOK, FT.—(Seventh Corps Area) P. O. Ft. Crook, Nebr. Corps Area Hq. Flight. Intermediate Landing Field. Reserve Flying.
- DETROIT, MICH.—(Chief of the Air Corps) P. O. 802 Farwell Bldg., Detroit, Mich. Procurement Planning Representative. Air Corps Procurement District.
- DODD FIELD—(Eighth Corps Area) P. O. Ft. Sam Houston, Texas. Airdrome.
- DOUGLAS, ARIZONA—(Eighth Corps Area) P. O. Douglas, Arizona. Airdrome. Intermediate Landing Field.
- DRYDEN, TEXAS—(Eighth Corps Area) P. O. Dryden, Texas. Border Patrol Station. Airdrome. Intermediate Landing Field.
- DUNCAN FIELD—(Chief of the Air Corps) P. O. San Antonio, Texas. Supply and Repair Depot.
- EDGEWOOD ARSENAL—P. O. Edgewood, Md. Air Corps Detachment.
- FAIRFIELD AIR DEPOT—(Chief of the Air Corps) P. O. Patterson Field, Fairfield, Ohio. Supply and Repair Depot.
- FRANCE FIELD—(P. C. Dept.) P. O. France Field, Canal Zone. 6th Composite Gp. Hq. 7th Obs. Sq. 12th Photo Section. 63d Service Sq. 24th, 78th Pursuit Sqs. 25th Bomb. Sq. Aerial Coast Defense. Panama Air Depot.
- GARDEN CITY—(Chief of the Air Corps) P. O. Long Island, N. Y. Air Corps Representative Curtiss Aeroplane & Motor Corp.
- HATBOX FIELD—(Eighth Corps Area) P. O. Muskogee, Okla. Intermediate Landing Field. Reserve Airdrome.
- HENSLEY FIELD—(Eighth Corps Area) P. O. Grand Prairie, Texas. Intermediate Landing Field. Reserve Airdrome.
- HOUSTON, FT. SAM—(Eighth Corps Area) P. O. Ft. Sam Houston, Texas. Airway Control Officer. Air Corps Detach. 8th Corps Area.
- KELLY FIELD—(Chief of the Air Corps) P. O. Kelly Field, Texas. Advanced Flying School. 39th, 40th, 41st, 42d, 43d School Sqs. 68th Service Sq. 22d Photo Section. Flying Cadet Detach.
- LANGLEY FIELD—(Third Corps Area) P. O. Hampton, Va. Hq. 2d Bomb. Wing. 19th Airship Co. Hq. 2d Bomb. Gp. 20th, 49th, 96th Bomb. Sqs. 1st Bomb. Brigade Hq. 28th Communication Section. 58th, 59th Service Sqs. 2d Photo Section. Flying Field. Flight A, 16th Obs. Sq. 8th Pursuit Gp. Hq. 33d, 35th, 36th Pursuit Sqs.
- LEAVENWORTH, FT.—P. O. Ft. Leavenworth, Kansas. Air Corps Detach. Intermediate Landing Field.
- LONG BEACH, CALIF.—(Formerly Clover Field) Municipal Airport. Reserve Airdrome.
- LOGAN FIELD—(Third Corps Area) P. O. Dundalk, Md. Intermediate Landing Field. Flying Field for 104th Obs. Sq., Md. National Guard.
- LORDSBURG—(Eighth Corps Area) P. O. Lordsburg, N. M. Airdrome. Intermediate Landing Field.
- LUKE FIELD—(H. Dept.) P. O. Honolulu, T. H. Hq. 5th Composite Gp. 4th, 50th Obs. Sqs. 23d, 72d Bomb. Sqs. 65th Service Sq. 11th Photo Section. Aerial Coast Defense. Air Depot.
- LUNKEN AIRPORT—(Fifth Corps Area) P. O. Cincinnati, Ohio. (Station (C)). Airdrome. Intermediate Landing Field. Reserve Airdrome.
- MCINTOSH, FT.—(Eighth Corps Area) P. O. Ft. McIntosh, Texas. Intermediate Landing Field.
- MARCH FIELD—(Ninth Corps Area) P. O. Riverside, Calif. 1st Bomb. Wing Hq. 7th Bomb. Gp. Hq. 9th, 11th, 31st Bomb. Sqs. 17th Pursuit Gp. Hq. 34th, 73d, 95th Pursuit Sqs. 64th, 70th Service Sqs. 23d Photo Section.
- MARSHALL FIELD—(Seventh Corps Area) P. O. Ft. Riley, Kans. Flight D, 16th Obs. Sq.
- MATHER FIELD—(Ninth Corps Area) P. O. Mills, Calif. 20th Pursuit Gp. Hq. 55th, 77th Pursuit Sqs. 80th Service Sq.
- MAXWELL FIELD—(Chief of the Air Corps) P. O. Montgomery, Ala. 4th Photo Section. Hq. Tactical School. 51st, 54th School Sqs.
- MIDDLETOWN AIR DEPOT—(Chief of the Air Corps) P. O. Middletown, Pa. Repair & Supply Depot. Flying Field.
- MITCHEL FIELD—(Second Corps Area) P. O. Mitchel Field, L. I., N. Y. Hq. 9th Obs. Gp. 1st, 5th, 99th Obs. Sqs. 8th, 14th Photo Sections. 61st Service Sq. 19th Composite Wing Hq.
- NEW YORK—(Chief of the Air Corps) P. O. 39 Whitehall St., New York City, N. Y. District Office Procurement Section (Material Division) Procurement Planning Representative. Air Corps Procurement District.
- NICHOLS FIELD—(P. Dept.) P. O. Maricaban, Rizal, P. I. Hq. 4th Composite Gp. 66th Service Sq. 6th Photo Section. 28th Bomb. Sq. 2d Obs. Sq. Philippine Air Depot.
- OFFUTT FIELD—(Seventh Corps Area) P. O. Ft. Crook, Nebr. Corps Area Hq. Flight Intermediate Landing Field. Reserve Flying.
- PATERSON FIELD—(Chief of the Air Corps) P. O. Fairfield, Ohio. Fairfield Air Depot. Supply & Repair.
- PEARSON FIELD—(Ninth Corps Area) P. O. Vancouver, Wash. Intermediate Landing Field. Reserve Airdrome.
- PHILLIPS FIELD—P. O. Aberdeen Proving Ground, Md. Air Corps Detach.
- PITTSBURGH AIRPORT—(Third Corps Area) R. D. No. 2, Sharpsburg, Pa. Airport. Intermediate Landing Field. Reserve Airdrome.
- POPE FIELD—(Fourth Corps Area) P. O. Ft. Bragg, N. C. Flying Field. See Ft. Bragg for troops.
- PORT COLUMBUS—(Fifth Corps Area) P. O. Columbus, Ohio. Air Corps Detach. Intermediate Landing Field. Reserve Airdrome.
- POST FIELD—P. O. Ft. Sill, Okla. Flight E, 16th Obs. Sq. 1st Balloon Co. Flying Field.

- RANDOLPH FIELD**—(Chief of the Air Corps) P. O. Randolph Field, Texas. Primary Flying School. Hq. A. C. Training Center. Hq. & Hq. Sq. 46th, 47th, 52d & 53d School Sqs. 67th Service Sq. 20th Photo Section. Flying Cadet Detach. School of Aviation Medicine.
- RICHARDS FIELD**—(Seventh Corps Area) P. O. Kansas City, Mo. Intermediate Landing Field. Reserve Airdrome. (Part of Kansas City Municipal Airport.)
- ROCKWELL FIELD**—(Chief of the Air Corps) P. O. Rockwell Field, Coronado, Calif. Supply & Repair Depot. Flying Field. 19th Bomb. Gp. Hq. 30th, 32d Bomb. Sqs. 76th Service Sq.
- ROSS FIELD**—(Ninth Corps Area) P. O. Arcadia, Calif. Detach 91st Obs. Sq. Intermediate Landing Field.
- RUSSELL, Ft. D. A.**—(Eighth Corps Area) P. O. Marfa, Texas. Airdrome. Intermediate Landing Field.
- SALT LAKE CITY**—Municipal Airport. P. O. Salt Lake City, Utah. (Formerly Woodward Field.) Reserve Airdrome.
- SAN ANTONIO AIR DEPOT**—(Chief of the Air Corps) P. O. Duncan Field, Texas. Supply & Repair Depot.
- SAN FRANCISCO**—(Chief of the Air Corps) P. O. Room 624, Exchange Block, 369 Pine St., San Francisco, Calif. Procurement Planning Representative. Air Corps Procurement District.
- SANTA MONICA**—(Chief of the Air Corps) P. O. 3000 Ocean Park Blvd., Santa Monica, Calif. District Procurement Office. Production Manager, Air Corps Representative, Douglas Aircraft Co.
- SCHOEN FIELD**—(Fifth Corps Area) P. O. Ft. Benjamin Harrison, Ind. Intermediate Landing Field. Reserve Airdrome.
- SCOTT FIELD**—(Chief of the Air Corps) P. O. Scott Field, Belleville, Ill. 9th Airship Co. 21st Airship Gp. Hq. 5th, 21st Photo Sections. 15th Obs. Sq. 24th Airship Service Co. Balloon & Airship School. Air Depot. Flying Field.
- SEATTLE**—(Chief of the Air Corps) P. O. c/o Boeing Airplane Co., Georgetown Station, Seattle, Wash. District Procurement Office. Air Corps Representative, Boeing Airplane Co. Municipal Airport. Reserve Airdrome.
- SELFRIDGE FIELD**—(Sixth Corps Area) P. O. Mt. Clemens, Mich. Hq. 1st Pursuit Gp. 17th, 27th, 94th Pursuit Sqs. 57th Service Sq. Flying Field.
- SHAFTER, Ft.**—(H. Dept.) P. O. Address, Ft. Shafter, T. H. 18th Composite Wing Hq.
- SHERIDAN, Ft.**—(Sixth Corps Area) P. O. Ft. Sheridan, Ill. Corps Area Hq. Flight Intermediate Landing Field.
- TUCSON**—(Eighth Corps Area) P. O. Tucson, Arizona. Airdrome. Intermediate Landing Field.
- WHEELER FIELD**—(H. Dept.) P. O. Schofield Barracks, Honolulu, T. H. 18th Pursuit Gp. 6th, 19th Pursuit Sqs. 26th Attack Sq. 75th Service Sq. Flying Field.
- WRIGHT FIELD**—(Chief of the Air Corps) P. O. Dayton, Ohio. Material Division. Engineering School. Experimental Engineering Section. Procurement Planning Representative. Repair & Maintenance Section. Industrial War Plans. Field Service Section. Procurement Section. A. C. Procurement District.

Corps Area and Department Air Officers

First Corps Area	Army Base, Boston 9, Mass.
Second Corps Area	Governors Island, N. Y.
Third Corps Area	United States Post Office & Court House, Baltimore, Md.
Fourth Corps Area	Hq. Ft. McPherson, Ga. Mail Address: Oakland City Sta., Atlanta, Ga.
Fifth Corps Area	Ft. Hayes, Columbus, Ohio
Sixth Corps Area	1819 W. Pershing Road, Chicago, Ill.
Seventh Corps Area	Baird Bldg., Omaha, Nebr.
Eighth Corps Area	Ft. Sam Houston, San Antonio, Texas
Ninth Corps Area	Presidio of San Francisco, Calif.
The Philippine Department	Manila, P. I.
The Hawaiian Department	Ft. Shafter, T. H.
The Panama Canal Department	Quarry Heights, C. Z.

Organized Reserve Airdromes and Stations for Reserve Flying—Boston Airport, Bowman Field, Candler Field, Hatbox Field, Hensley Field, Kansas City Airport, Lunken Airport, Pearson Field, Pittsburgh Airport, Port Columbus, Schoen Field. Also municipal airports—Chicago, Ill.; Long Beach, Calif.; Salt Lake City, Utah; Seattle, Wash.

Note: Reserve flying also conducted at Air Corps Stations at which one or more Air Corps units are operating.

Air Depots—Fairfield, Hawaii, Middletown, Panama, Philippines, Rockwell, San Antonio, Scott Field.

Special Service Schools—Advanced Flying School, Kelly Field, Texas; Primary Flying School, Randolph Field, Texas; Tactical School, Maxwell Field, Montgomery, Ala.; Technical School, Chanute Field, Rantoul, Ill.; Engineering School, Wright Field, Dayton, Ohio; School of Aviation Medicine, Randolph Field, Texas; Balloon & Airship School, Belleville, Ill.

Air Corps National Guard Units

	<i>Organization</i>	<i>P. O. Address</i>
101st	Obs. Sq. & Photo Sec., Mass.	Nat. Guard, Boston Airport, Boston, Mass.
102nd	Obs. Sq. & Photo Sec., N. Y.	Nat. Guard, Miller Field, Staten Island, N. Y.
103rd	Obs. Sq.	Penn. Nat. Guard, The Armory, Philadelphia Airport, Paschall Post Office, Philadelphia, Pa.
104th	Obs. Sq. & Photo Sec., Md.	Nat. Guard, Logan Field, Baltimore, Md.
105th	Obs. Sq. & Photo Sec., Tenn.	Nat. Guard, Sky Harbor Airport, Nashville, Tenn.
106th	Obs. Sq. & Photo Sec., Ala.	Nat. Guard, Roberts Field, P. O. Box # 570, Birmingham, Ala.
107th	Obs. Sq. & Photo Sec., Mich.	Nat. Guard, Wayne Co. Airport, Route # 1, Romulus, Mich.
108th	Obs. Sq.	Ill. Nat. Guard, Municipal Airport, Chicago, Ill.
109th	Obs. Sq. & Photo Sec., Minn.	Nat. Guard, Municipal Airport, St. Paul, Minn.
110th	Obs. Sq. & Photo Sec., Mo.	Nat. Guard, Lambert-St. Louis Municipal Airport, Robertson, Mo.
111th	Obs. Sq. & Photo Sec., Tex.	Nat. Guard, Route 1, Box # 655, Houston, Texas
112th	Obs. Sq.	Ohio Nat. Guard, Cleveland Airport, Cleveland, Ohio
113th	Obs. Sq. & Photo Sec., Ind.	Nat. Guard, RR 3, Box # 28, Indianapolis, Ind.
115th	Obs. Sq. & Photo Sec., Cal.	Nat. Guard, Los Angeles Airport, Griffith Park, Cal.
116th	Obs. Sq. & Photo Sec., Wash.	Nat. Guard, Felts Field, Parkwater, Wash.
118th	Obs. Sq. & Photo Sec., Conn.	Nat. Guard, P. O. Box # 931, Hartford, Conn.
119th	Obs. Sq. & Photo Sec., N. J.	Nat. Guard, Newark Airport, Newark, N. J.
120th	Obs. Sq. & Photo Sec., Colo.	Nat. Guard, Lowry Field, Denver, Colo.
154th	Obs. Sq.	Ark. Nat. Guard, Room # 428, State Capitol, Little Rock, Ark.

District Procurement and Planning Representatives

Buffalo	Wright Field
Chicago	New York
Detroit	San Francisco

Air Corps Procurement Districts

Buffalo, N. Y.	65 Franklin St.
Chicago, Ill.	1212 & 1213 Buckingham Bldg., 50 East Van Buren, Chicago, Ill.
Cleveland, Ohio	Wright Field, Dayton, Ohio
Detroit, Mich.	802 Farwell Bldg.
New York, N. Y.	39 Whitehall St.
San Francisco, Calif.	309 Pine St.

Materiel Division

Wright Field, Dayton, Ohio

Brig. Gen. Henry C. Pratt, Chief of the Division

Executive	Lieut. Col. A. W. Robins
Asst. Executive	Major Robert Walsh
Asst. Executive	Captain A. E. Jones
Commanding Officer	Major Robert Goolrick
Supply Officer	Captain Alonzo M. Drake
Chief, Engineering Section	Major Clinton W. Howard
Chief, Procurement Section	Major H. A. Strauss
Chief, Field Service Section	Major Hugh J. Knerr
Chief, Industrial War Plans Section	Captain R. B. Hough, Jr.
Finance Officer	Captain Louis H. Price
Asst. Commandant A. C. Engineering School	Captain F. M. Hopkins
Adjutant	Captain D. B. Howard
Quartermaster	Captain S. W. McIlwain
Signal Officer	Captain Tom C. Rives
Engineer Corps Representative	Captain Bruce C. Hill
Ordnance Corps Representative	Major J. L. Hatcher
Navy Representative	Lieut. Comdr. R. P. McConnel

AVIATION COUNTRY CLUB OF LONG ISLAND

Hicksville, L. I., N. Y.

Charles L. Lawrance	President
Edward O. McDonnell	Vice-President
Roland Palmedo	Treasurer
James B. Taylor, Jr.	Secretary
Thomas J. Lawson	Assistant Secretary and Treasurer

AIRCRAFT YEAR BOOK

Board of Governors

Charles L. Lawrance	Miles Vernon	George B. Post
Edward O. McDonnell	Luis de Florez	John W. Andrews
Roland Palmado	Lawrence Turnure, Jr.	R. R. Loening
James B. Taylor, Jr.	Richard F. Hoyt	B. Allison Gillies

Richard H. Depew, Jr., vice-president, in charge of flying, and manager

AVIATION COUNTRY CLUB OF WESTCHESTER

Armonk Village, N. Y.

Robert Law	President
George M. Pynchon, Jr.	Vice-President
William W. Brinkerhoff	Treasurer
Luke B. Lockwood	Secretary

Board of Governors

Robert Law	Maj. Gen. John J. O'Ryan	George H. Townsend
J. Noel Macy	George M. Pynchon, Jr.	R. Stewart Kilborne, Jr.
Eugene Detmer	J. J. White	Earl D. Osborn
W. W. Brinkerhoff		William A. Rockefeller

Edward Jones, in charge of flying operations and manager

AVIATION COUNTRY CLUB OF PHILADELPHIA

Blue Bell, Philadelphia, Pa.

Donald D. Darby	President
Marshall E. Reid	Vice-President
Kern Dodge	Treasurer
Hazleton Mirkil	Secretary

Board of Governors

F. W. Cortright	Wallace W. Kellett	J. Story Smith
William Day	Charles T. Ludington	E. Burke Wilford
A. F. duPont, Jr.	Dr. T. McKean Downs	Robert Glendinning, Jr.
	R. S. Saltus, Jr.	

AVIATION COUNTRY CLUB OF NEW JERSEY

Caldwell, N. J.

Walter S. Marvin	President
Donald D. Cooke	Vice-President
E. H. Klipstein	Secretary and Treasurer

Board of Governors

Donald D. Cooke	E. H. Klipstein	Walter S. Marvin
	Wesley Trimpi	

AVIATION COUNTRY CLUB OF LAKE CHAMPLAIN

Westport, N. Y.

John T. de Blois Wack	President
Major W. M. Wier	Vice-President
Harry P. Smith	Secretary and Treasurer

Board of Governors

Garret A. Hobart	A. Gibson Payne	Harry P. Smith
James C. Stephens	W. M. Wier	John T. de Blois Wack

AVIATION COUNTRY CLUB OF SEATTLE

Seattle, Washington

Thomas D. Stimson	President
H. A. Munter	Vice-President
Donald G. Graham	Secretary and Treasurer

Board of Governors

Lieutenant E. T. Kennedy	John D. Price	Donald G. Graham
C. W. Stimson		H. A. Munter

DEPARTMENT OF COMMERCE

Aeronautics Branch

Washington, D. C.

- Clarence M. Young, Assistant Secretary of Commerce for Aeronautics
S. W. Crosthwaite, Chief, Administrative Division
- Director of Air Regulation..... Gilbert G. Budwig
 Chief Inspector—Western Division..... Walter F. Parkin
 Chief Inspector—Central Division..... J. S. Marriott
 Chief Inspector—Eastern Division..... George E. Gardner
 Chief, Licensing Division..... W. Fiske Marshall
 Chief, Registration Section..... R. R. Reining
 Chief, Medical Section..... Dr. R. F. Longacre
 Chief, Engineering Section..... Richard C. Gazley
 Chairman, Accident Board..... Jesse W. Lankford
 Chief, Enforcement Section..... Richard S. Paulett
- Director of Aeronautic Development..... Harry H. Blee
 Chief, Aeronautic Information Section..... F. R. Neely
 Chief, Airport Section..... A. Pendleton Taliaferro, Jr.
 Chief, Statistics and Distribution Section..... Earle R. Strong
 Chief, Editorial Section..... George Gardner
- Chief Engineer, Airways Division..... F. C. Hingsburg
 Airways Engineer..... C. I. Stanton
 Administrative Officer..... L. W. Lawrence
 Radio Engineer..... H. J. Walls
 Chief, Weather and Communications Section..... Eugene Sibley
 Chief, Construction Section..... A. J. LaBaie
 Supt. Airways Extension..... W. T. Miller
- Air Mapping Section (Coast and Geodetic Survey)
 Chief, Air Mapping Section..... Raymond L. Ross
- Aeronautical Research Division (Bureau of Standards)
 Chief, Aeronautical Research..... Dr. L. J. Briggs

DIPLOMATIC SERVICE TO THE UNITED STATES

- Cuba..... Senor Don Martin Arostogui, Attaché for Aeronautics.
 France..... Major Georges Thenault, Air Attaché.
 Great Britain..... Group Captain The Honorable L. J. Fiennes, R. A. F., Air Attaché.
 Hungary..... Lieut. Colonel Count Marcel Stomm, Military Attaché.
 Italy..... Commander Paolo Sbernadori, Air Attaché.
 Japan..... Colonel Shizuichi Tanaka, I. J. A., Military Attaché.
 Mexico..... Sr. Coronel Don Francisco J. Aguilar, Military Attaché.
 Spain..... Major Joaquin Planell Riera, Spanish Army, Military Attaché.
 Poland..... Mr. Andrew Sapieha, Commercial Counselor.
 Argentina..... Sr. Tenient Coronel Don Ricardo Miro, Military Attaché.
 Colombia..... Coronel Don Jorge Mercado, Military Attaché.
 Sweden..... Capt. Count Gustaf-Fredrik von Rosen, Military Attaché.

DIPLOMATIC SERVICE OF THE UNITED STATES

Army

- Berlin, Germany..... Lieut. Colonel Jacob W. S. Wuest, U. S. A., Assistant Military Attaché for Air; Germany and Switzerland.
 Paris, France..... Colonel Frank P. Lahm, U. S. A., Assistant Military Attaché for Air; France and Spain.
 London, England..... Major Martin F. Scanlon, U. S. A., Assistant Military Attaché for Air; Great Britain.
 Rome, Italy..... Captain Francis M. Brady, U. S. A., Assistant Military Attaché for Air; Italy and Greece.

Navy

- London, England..... Lieut. Comdr. George D. Murray, U. S. N., Assistant Naval Attaché. (Additional duty Paris, The Hague, Berlin and The Netherlands.)
 Rome, Italy..... Lieut. Eliot Hinman Bryant, U. S. N., Assistant Naval Attaché. (Additional duty Stockholm and Copenhagen.)

**FLYING SCHOOLS GRANTED APPROVED CERTIFICATES
BY DEPARTMENT OF COMMERCE**

<i>Name and Location</i>		<i>Ratings for which Approved</i>	<i>Approved Certificate Issued</i>
Airtech Flying Service, Inc. Lindbergh Field San Diego, Calif.	Ground and Flying	{ Transport Lim. Commercial Private	7-15-29
Parks Air College, Inc. Parks Airport East St. Louis, Ill.	Ground and Flying	{ Transport Lim. Commercial Private	7-15-29
D. W. Flying Service LeRoy Airport LeRoy, N. Y.	Ground and Flying	{ Lim. Commercial	7-15-29
Curtiss Valley Stream Field, Inc. Valley Stream Airport Valley Stream, L. I., N. Y. (Flying) In combination with New York University 51 W. 4th Street New York City (Ground)	Ground and Flying	{ Transport Lim. Commercial Private	2- 6-30 8-14-29
Boeing School of Aeronautics Oakland Municipal Airport Oakland, Calif.	Ground and Flying	{ Transport Lim. Commercial Private	10-17-29
Spartan School of Aeronautics Apache Blvd. and Chamberlain Drive Tulsa, Okla.	Ground and Flying	{ Transport Lim. Commercial Private	10-18-29
Roosevelt Aviation School, Inc. Roosevelt Field No. 1 Mineola, L. I., N. Y.	Ground and Flying	{ Transport Lim. Commercial Private	10-25-29
Penn School of Aviation Pittsburgh-Butler Airport Butler, Pa.	Ground and Flying	{ Transport Lim. Commercial Private	12-12-29
Lincoln Airplane & Flying School 2415 O Street (Ground) Municipal Airport (Flying) Lincoln, Nebr.	Ground and Flying	{ Transport Lim. Commercial Private	3-31-30
Yellow Cab School of Aviation Municipal Airport Des Moines, Iowa	Ground and Flying	{ Transport Lim. Commercial Private	4- 3-30
Furniture Capital Air Service Grand Rapids Airport Grand Rapids, Mich.	Ground and Flying	{ Transport Lim. Commercial	8-21-30
Dallas Aviation School and Air College Love Field Dallas, Texas	Ground and Flying	{ Transport Lim. Commercial Private	12-22-30
Penn School of Aviation Bettis Airport (Flying) In combination with Pittsburgh Auto & Aviation School 405 Penn Ave. (Ground) Pittsburgh, Pa.	Ground and Flying	{ Lim. Commercial Private	9-28-31
Birmingham Air Service, Inc. Municipal Airport Birmingham, Ala.	Ground and Flying	{ Private	11-10-31
Aereco Flying Service, Inc. Municipal Airport Fort Wayne, Ind.	Ground and Flying	{ Private	1-22-32

<i>Name and Location</i>		<i>Ratings for which Approved</i>	<i>Approved Certificate Issued</i>
Golden State Flying Service, Inc. Los Angeles Municipal Airport Inglewood, Calif. (Ground and Flying) In combination with Curtiss-Wright Technical Institute of Aeronautics 1224 Airway St. Glendale, Calif. (Ground)	Ground and Flying	{ Transport Lim. Commercial Private	4-15-32
Baltimore Air Terminals, Inc. Curtiss-Wright Airport Baltimore, Md.	Ground and Flying	{ Transport Lim. Commercial Private	6- 9-32
Ryan School of Aeronautics, Ltd. Lindbergh Field San Diego, Calif.	Ground and Flying	{ Transport Lim. Commercial Private	9- 1-32
Chicago Air Terminals, Inc. Curtiss-Reynolds Airport Glenview, Ill.	Ground and Flying	{ Transport Lim. Commercial Private	7-15-32
Los Angeles Aircraft, Ltd. Los Angeles Municipal Airport Inglewood, Calif.	Ground and Flying	{ Private	7-30-32
Erickson & Remmert Floyd Bennett Field Brooklyn, N. Y. In combination with New York University	Ground and Flying	{ Private	10-22-32

MANUFACTURERS AIRCRAFT ASSOCIATION, INC.

300 Madison Avenue, New York, N. Y.

Officers

President.....	Frank H. Russell
Vice-Presidents.....	{ J. Don Alexander Eugene E. Wilson E. T. Asplundh
Treasurer.....	Clayton J. Brukner
Secretary.....	Walter C. Davis
General Manager.....	S. S. Bradley
Comptroller.....	W. Russell Root
Director of Patent Research.....	John A. Sanborn

Directors

J. Don Alexander	Walter C. Davis	W. A. Mara
E. T. Asplundh	Donald Douglas	Glenn L. Martin
Charles F. Barndt	Reuben H. Fleet	Frank H. Russell
Clayton J. Brukner	F. S. Hubbard	Eugene E. Wilson

The MANUFACTURERS AIRCRAFT ASSOCIATION, INC., organized in July, 1917, had for its primary purpose, the administration of a cross-licensing agreement between manufacturers of airplanes owning a group of several hundred patents, including those covering the basic Wright and Curtiss inventions. The Cross-License Agreement of July 24, 1917 was superseded by "The Amended Cross-License Agreement of December 31, 1928," which is now in force. The latter agreement which is printed in full in the Aircraft Year Book for 1929 (page 363), has been adopted by nearly all airplane manufacturers in the United States. The War and Navy Departments have also contracted with the Association for Licenses under patents of all members. The Amended Agreement further provides for the cross-licensing of all new patents acquired by members, with provision for award of royalties, determined by arbitration, on meritorious inventions. The Association maintains a Patent Research Division and publishes semi-monthly for distribution to members a current Digest of U. S. airplane patents, showing official drawings. The Association also has an extensive library comprised of United States and foreign patents, books, other publications and documents, and renders a general patent service to members.

Members, Applicants for Membership and Licensees

Aeromarine Plane & Motor Co., Inc.
 Aeronautical Corporation of America
 Alexander Industries, Inc.
 American Aeronautical Corporation
 American Eagle Aircraft Corporation
 Amphibions, Inc.
 Bird Aircraft Corporation
 B/J Aircraft Corporation
 Boeing Airplane Company
 Breese Aircraft Corporation
 Buhl Aircraft Company
 Butler Aircraft Corporation
 Cessna Aircraft Company
 Consolidated Aircraft Corporation
 Curtiss Aeroplane & Motor Co., Inc.
 Curtiss-Caproni Corporation
 Curtiss-Wright Airplane Company (Mo.)
 Curtiss-Wright Airplane Company (Del.)
 Davis Aircraft Corporation
 Dayton-Wright Company
 Douglas Aircraft Company, Inc.
 G. Elias & Bro., Inc.
 Fleet Aircraft Corporation
 General Aviation Corporation

Great Lakes Aircraft Corporation
 Hall-Aluminum Aircraft Corporation
 Keystone Aircraft Corporation
 Lockheed Aircraft Company
 Loening Aeronautical Engineering Corporation
 Glenn L. Martin Company
 Mercury Aircraft, Inc.
 Monocoupe Corporation
 Navy Dept. of the U. S.
 Nicholas-Beazley Airplane Co., Inc.
 Pitcairn Aircraft, Inc.
 Ryan Aircraft Corporation
 Sikorsky Aviation Corporation
 Spartan Aircraft Company
 Stearman Aircraft Company
 Stinson Aircraft Corporation
 Sturtevant Aeroplane Company
 Szekely Aircraft & Engine Company
 Thomas-Morse Aircraft Corporation
 Viking Flying Boat Company
 Chance Vought Corporation
 Waco Aircraft Company
 War Dept. of the U. S.
 Wright Aeronautical Corporation

NATIONAL ADVISORY COMMITTEE FOR AERONAUTICS

3841 Navy Building, Washington, D. C.

Joseph S. Ames, Ph.D., Chairman, President, Johns Hopkins University, Baltimore, Md.	Colonel Charles A. Lindbergh, New York City.
David W. Taylor, D.Eng., Vice Chairman, Washington, D. C.	William P. MacCracken, Jr., Ph.B., Washing- ton, D. C.
Charles G. Abbot, Sc.D., Secretary, Smith- sonian Institution, Washington, D. C.	Charles F. Marvin, M.E., Chief, United States Weather Bureau, Washington, D. C.
Arthur B. Cook, Captain, United States Navy, Asst. Chief, Bureau of Aeronautics, Navy Department, Washington, D. C.	William A. Moffett, Rear Admiral United States Navy, Chief, Bureau of Aeronautics, Navy Department, Washington, D. C.
William F. Durand, Ph.D., Professor Emeritus of Mechanical Engineering, Stanford Uni- versity, Calif.	Henry C. Pratt, Brigadier General, United States Army, Chief, Materiel Division, Air Corps, Wright Field, Dayton, Ohio.
Benjamin D. Foulois, Major General, United States Army, Chief of Air Corps, War Department, Washington, D. C.	Edward P. Warner, M.S., Editor "Aviation," New York City.
Harry F. Guggenheim, M.A., The American Ambassador, Havana, Cuba.	Orville Wright, Sc.D., Dayton, Ohio.
George W. Lewis, Director of Aeronautical Research.	Henry J. E. Reid, Engineer in Charge, Lang- ley Memorial Aeronautical Laboratory, Langley Field, Va.
John F. Victory, Secretary.	

John J. Ide, Technical Assistant in Europe, Paris, France.

Executive Committee

Joseph S. Ames.....	Chairman
David W. Taylor.....	Vice Chairman
John F. Victory.....	Secretary

Charles G. Abbot	William P. MacCracken, Jr.
Arthur B. Cook	Charles F. Marvin
Benjamin D. Foulois	William A. Moffett
Col. Charles A. Lindbergh	Henry C. Pratt
Edward P. Warner	
Orville Wright	

NATIONAL AERONAUTIC ASSOCIATION OF U. S. A., INC.

National Headquarters, Dupont Circle, Washington, D. C.

Representative in U. S. A. of Fédération Aéronautique Internationale

Hiram Bingham.....	President
Robert J. Pritchard.....	Vice President
H. Ralph Badger.....	Secretary
John F. Victory.....	Treasurer

Advisory Board

Joseph S. Ames
 Harry H. Blee
 Richard E. Byrd
 F. Trubee Davison
 James H. Doolittle
 Amelia Earhart
 Benjamin D. Foulois
 W. Irving Glover

Harry F. Guggenheim
 Frank Hawks
 David S. Ingalls
 Reed Landis
 Charles A. Lindbergh
 Charles F. Marvin
 William A. Moffett
 Clarence M. Young

Executive Committee

Porter Adams, Chairman

J. W. Beretta
 Ray Cooper
 Charles L. Lawrence
 George W. Lewis

C. F. Lienesch
 Winship Nunnally
 F. G. Smart, Jr.
 R. F. Taylor

NAVAL AVIATION OFFICIALS

Bureau of Aeronautics

Chief of Bureau..... Rear Admiral William A. Moffett
 Assistant Chief of Bureau... Capt. Arthur B. Cook
 Aide to the Chief..... Lieut. T. H. Robbins
 Captain..... E. A. Cobey (SC)
 Commanders..... H. B. Cecil, G. Fulton (CC), M. A. Mitscher, C. A. Pownall,
 A. C. Read, R. K. Turner, W. W. Webster, R. D. Weyerbacher.
 Lieut. Commanders..... J. R. Allen (CC), R. S. Barnaby (CC), J. D. Barner, M. R. Brown-
 ing, J. H. Campman, A. C. Davis, W. S. Diehl (CC), G. R.
 Fairlamb, Jr., R. W. Fleming, H. S. Kendall, R. D. MacCart
 (CC), A. C. McFall, Gail Morgan, C. A. Nicholson (CC),
 A. I. Price, J. D. Price, A. W. Radford, L. B. Richardson
 (CC), D. Royce (CC), H. B. Sallada, F. B. Stump, R. E. Thomas
 (CEC), J. J. White (MC) (M&S).
 Lieutenants..... M. E. Browder, W. H. Buracker, R. R. Dennett, N. A. Drain
 (CC), R. E. Farnsworth, H. H. Goodwin, J. W. Harris, J. P.
 Heath, M. M. Kindell, F. Lee, L. J. Maxson (CC), I. M.
 McQuiston (USNR), T. J. O'Brien, Paul E. Pihl (CC), H. E.
 Regan, Jr.; G. A. Seitz, C. W. Smith, H. W. Taylor, W. G.
 Tomlinson.
 Lieutenants (Junior grade)... J. P. Fitzsimmons, W. D. Rowley, H. B. Temple, R. R. Waller.
 Marine Corps Aviation..... Majors J. E. Davis; R. S. Geiger.
 Captains W. G. Farrell; T. R. Shearer; L. E. Wood.
 Lieutenants H. P. Becker; F. H. Lamson-Scribner; Wm. C. Lemly.
 U. S. Army Liaison Officer... Captain W. H. Brookley.

Naval Air Stations

<i>Name</i>	<i>Commanding Officer</i>
Lakehurst, N. J.....	Capt. H. E. Shoemaker
Anacostia, D. C.....	Capt. W. G. Child
Norfolk, Va.....	Capt. A. W. Fitch
San Diego, Calif.....	Comdr. J. H. Hoover
Seattle, Wash.....	Lieut. Comdr. G. S. Gillespie
Pensacola, Fla.....	Capt. R. F. Zogbaum
Pearl Harbor, T. H.....	Comdr. E. W. Tod
Coco Solo, C. Z.....	Comdr. R. P. Molten

Marine Corps Flying Fields

Quantico, Va..... Lieut. Col. Ross E. Rowell
 San Diego, Calif..... Major L. M. Bourne
 Managua, Nicaragua..... Capt. F. P. Mulcahy
 Port au Prince, Haiti..... Major J. T. Moore

Carrier Divisions

Commander..... Rear Admiral H. E. Yarnell
 (Aircraft Battle Force and Aircraft U. S. Fleet)
 Chief of Staff..... Captain John H. Towers
 U. S. S. Lexington—Commanding Officer..... Captain C. A. Blakely
 U. S. S. Saratoga—Commanding Officer..... Captain G. W. Steele
 U. S. S. Langley—Commanding Officer..... Commander P. N. L. Bellinger

Airships

U. S. S. Akron—Commanding Officer..... Commander Alger H. Dressel

Naval Aircraft Factory

Philadelphia, Penna.—Manager Commander S. M. Kraus

Special Aviation Duty

Aide to Commander-in-Chief, U.S. Fleet	Lieut. Comdr. Jack H. Duncan
Aide to Commander-in-Chief, Battle Force	Lieut. John W. Roper
Aide to Commander-in-Chief, Scouting Force	Lieut. W. D. Sample
Officer of Naval Operations	Lieut. Comdr. A. C. Davis
Office of Fleet Training	Lieut. Comdr. Gail Morgan
Naval Examining Board	Lieut. Comdr. R. Irvine
Board of Inspection and Survey	Lieut. Comdr. T. P. Jeter
Bureau of Navigation	Commander H. C. Wick
	Lieut. Comdr. V. H. Ragsdale
	Lieut. C. R. Brown
Bureau of Ordnance	Lieut. A. J. Isbell
Bureau of Engineering	Lieut. G. H. DeBaum
Hydrographic Office	Lieut. W. V. Saunders
	Lieut. J. F. Gillon

POST OFFICE DEPARTMENT AIR MAIL SERVICE

Washington, D. C.

Postmaster General	Walter F. Brown
Second Assistant Postmaster General	W. Irving Glover
Deputy Second Assistant Postmaster General	Chase C. Gove
Superintendent	E. B. Wadsworth
Assistant Superintendent	J. W. Sutherin

B. F. Myers, Assistant Superintendent	Chicago, Ill.
Joseph Menth, Assistant Superintendent	New York, N. Y.
A. O. Willoughby, Assistant Superintendent	San Francisco, Calif.
Fred M. Hirons, Assistant Superintendent	Atlanta, Ga.
Stephen A. Cisler, Assistant Superintendent	Port Worth, Texas

E. R. White, Director Division of International Postal Service

SOCIETY OF AUTOMOTIVE ENGINEERS, INC.

Aeronautic Officials

29 West 39th Street, New York, N. Y.

H. C. Dickinson	President
Clarence M. Young	Vice-President
	(Representing Aircraft Engineering)
A. V. D. Willgoos	Vice-President
	(Representing Aircraft-Engine Engineering)
Harte Cooke	Vice-President
	(Representing Diesel-Engine Engineering)
John A. C. Warner	Secretary and General Manager

The Council

H. C. Dickinson, Pres.	J. F. Winchester, Vice-Pres.
Clarence M. Young, Vice-Pres.	David Beecroft, Treasurer
A. V. D. Willgoos, Vice-Pres.	S. O. White, Councilor
Harte Cooke, Vice-Pres.	R. E. Wilson, Councilor
M. C. Horine, Vice-Pres.	H. T. Woolson, Councilor
J. M. Crawford, Vice-Pres.	Walter T. Fishleigh, Councilor
Roy R. Anderson, Vice-Pres.	Geo. W. Lewis, Councilor
Fred W. Cederleaf, Vice-Pres.	Wm. Guy Wall, Councilor
Past Presidents: A. J. Schaife (1932)	Vincent Bendix (1931)

Aeronautic Committees

Aircraft Activities	Clarence M. Young, Chairman
Aircraft-Engine Activities	A. V. D. Willgoos, Chairman
Standards Committee	
Aircraft Division	John F. Hardecker, Chairman
Aircraft-Engine Division	Robert Insley, Chairman

U. S. WEATHER BUREAU

Central Office, 24th and M Sts., N. W., Washington, D. C.

Charles F. Marvin..... Chief
 Charles C. Clark..... Assistant Chief
 William Weber..... Chief Clerk

Aerological Division

Willis R. Gregg..... Chief
 Leroy T. Samuels..... Assistant
 Paul A. Miller..... Field Organizer
 William C. Haines..... In Charge of Hoover Airport Station

Forecast Division

Edgar B. Calvert..... Chief

District Forecasting

Charles L. Mitchell..... District Forecaster
 R. Hanson Weightman..... District Forecaster

Instrument Division

Benjamin C. Kadel..... Chief

Field Organization—District Forecasting

Chicago..... Charles A. Donnell
 Denver..... Julius M. Sherier
 New Orleans..... Isaac M. Cline
 San Francisco..... Edgar H. Bowie

Central Airport Stations

(Formerly Major Control Airport Stations)

Atlanta..... Eugene M. Barto
 Cheyenne..... Henry P. Adams
 Chicago..... Fred H. Weck
 Cleveland..... Clarence G. Andrus
 Dallas..... John A. Riley
 Kansas City..... Leslie A. Warren
 Los Angeles..... George M. French
 New York (Newark Airport)..... Homer W. Ball
 Omaha..... Vincent E. Jakl
 Portland, Ore..... Julius C. Smith
 Salt Lake City..... Harry M. Hightman
 San Francisco (Oakland Airport)..... Delbert M. Little

TRADE INDEX

• DIVISION I •

AIRCRAFT AND ENGINE MANUFACTURERS

AIRPLANE MANUFACTURERS

AUTOGIRO COMPANY OF AMERICA, Pitcairn Field, Willow Grove, Pennsylvania

Owners of American rights to Autogiro aircraft manufacture
H. F. Pitcairn, Pres.; G. S. Childs, Executive Vice-Pres. and Treas.; E. T. Asplundh, Vice-Pres.; J. G. Ray, Vice-Pres.; K. C. Acton, Sec.; A. E. Larsen, Chief Engineer.

B/J AIRCRAFT CORPORATION Baltimore, Maryland Manufacturers and Designers of Aircraft

Div. of North American Aviation, Inc.
Temple N. Joyce, Pres.; Russel McGee, Vice-Pres.; F. S. Hubbard, Vice-Pres.; J. J. Mehl, Sec. & Treas.; G. M. Darsch, Asst. Sec. & Treas.; Wm. H. Miller, Ch. Engr.; M. L. Winter, Fcty. Mgr.

BELLANCA AIRCRAFT CORPORATION, New Castle, Delaware Bellanca Cabin Monoplanes Airbus, Skyrocket, Pacemaker

G. M. Bellanca, Pres.; L. Sherman Adams, Vice-Pres.; Andrew Bellanca, Sec.; A. D. Chandler, Treas.; L. W. Ashton, Sales Mgr.

BOEING AIRPLANE COMPANY Seattle, Washington (Subsidiary of United Aircraft) Military and Commercial Aircraft P. G. Johnson, President C. L. Egtvedt, Vice-President J. P. Murray, Vice-President D. R. Drew, Secretary H. E. Bowman, Treasurer

CURTISS AEROPLANE & MOTOR CO., Inc., Buffalo, N. Y.

A Division of the Curtiss-Wright Corporation — Military Aircraft
J. A. B. Smith, Pres.; T. P. Wright, Vice-Pres.; B. S. Wright, Vice-Pres.; B. G. Leighton, Vice-Pres.; Geo. S. Lapp, Treas.; R. R. Reger, Sec.
Cable Address—"Aeroexco"

CURTISS-WRIGHT AIRPLANE COMPANY

A Division of Curtiss-Wright Corporation. Factory: St. Louis, Missouri
Builders of sport planes, transports and military planes. Ralph S. Damon, Pres.; G. J. Brandeweide, Vice-Pres.; Wm. B. Robertson, Vice-Pres.; George M. Ebert, Treas.; R. R. Reger, Sec.
Cable Address—"Aeroexco"

FAIRCHILD AVIATION CORPORATION. Subsidiaries: Fairchild Aerial Camera Corp., and Fairchild Aerial Surveys, Inc., 62-10 Woodside Ave., Woodside, L. I.; Kreider-Reisner Aircraft Co., Inc., Hagerstown, Md.; Fairchild Aircraft, Ltd., Longueuil, P. Q., Canada.

GENERAL AVIATION MANUFACTURING CORPORATION Dundalk, Maryland Aircraft Manufacturers

James M. Schoonmaker, Jr., President
C. E. Wilson, Vice-President
John C. Felli, Treasurer
L. R. Beardslee, Secretary

GREAT LAKES AIRCRAFT CORPORATION, Cleveland, Ohio

Contractors to the U. S. Army & Navy
Manufacturers of commercial planes of merit and performance
Chas. F. Barndt, Pres.; P. B. Rogers, Vice Pres. and Ch. Engr.; Edward Rembert, Dir. of Sales; C. F. Lozon, Fcty. Mgr.

GROVER LOENING AIRCRAFT CO., Inc. Garden City, L. I., N. Y.
Experimental Aircraft Manufacturing
Grover Loening, Pres.; B. Allison
Gillies, Vice-Pres. and Treas.; Alvin E.
Moffett, Sec.; H. L. Gundry, Pur. Agt.
Directors: Grover Loening, B. A.
Gillies, David Bruce, E. Roland
Harrimen, R. R. Loening.

SIKORSKY AVIATION CORPORATION, Bridgeport, Conn. Sub. of
United Aircraft and Transport Corp.
Designers and manufacturers of single
and multi-motored transport amph-
ibions for private, commercial and gov-
ernment service. F. W. Neilson, Pres.
and Gen. Mgr.; I. I. Sikorsky, Vice-
Pres.; in Ch. Engineering; J. F.
McCarthy, Sec.

CHANCE VOUGHT CORPORATION
Subsidiary of

United Aircraft & Transport Corp.
East Hartford, Conn.

Designers and Manufacturers of Mili-
tary and Commercial Aircraft and Sea-
planes. Contractors to Governments of
United States and Foreign Countries.
E. E. Wilson, President

THE WACO AIRCRAFT COMPANY
Troy, Ohio

Manufacturers of WACO Airplanes
Clayton J. Brukner, President
Lee N. Brutus, Vice-Pres. and Treas.
L. E. St. John, Secretary
Hugh R. Perry, Sales Manager

ENGINE MANUFACTURERS

**ALLISON ENGINEERING
COMPANY**

Subsidiary of

General Motors Corporation
Indianapolis, Ind.

Aircraft Power Plant Engineering
and Construction

Allison Steel Back Bearings

PACKARD MOTOR CAR CO.

Detroit, Mich.

Packard-Diesel Aircraft Engines

Alvan Macauley, President
G. H. Brodie, Manager, Diesel Division;
Edward Macauley, Sales Mgr., Diesel
Division; H. C. Edwards, Chief Eng.,
Diesel Division.

**THE PRATT & WHITNEY AIR-
CRAFT CO., E. Hartford, Conn.**

(Division United Aircraft & Trans-
port Corp.) Wasp Jr., Wasp and
Hornet Aircraft Engines. F. B. Rent-
schler, Chairman of Board; D. L.
Brown, Pres.; G. J. Mead, Ch. Exec.
Comm.; C. W. Deeds, Vice-Pres. and
Sec.; A. V. D. Willgoos, Chief Eng.

WRIGHT AERONAUTICAL CORP.

(A Division of Curtiss-Wright Corp.)

Factory: Paterson, New Jersey

Manufacturers of

Wright "Whirlwind," "Cyclone" and
"Gipsy" and Curtiss "Conqueror"
and "Challenger" Engines. Guy W.
Vaughan, Pres.; Bruce Leighton, Vice-
Pres.; Arthur Nutt, Vice-Pres.; M. B.
Gordon, Treas.; R. R. Reger, Sec.
Cable Address—"Aeroexco"

• DIVISION II •

MANUFACTURERS OF: ACCESSORIES, MATERIALS AND SUPPLIES

**AIRPLANE ACCESSORIES,
MATERIALS, PARTS AND
SUPPLIES**

ALUMINUM COMPANY OF AMERICA, 2400 Oliver Bldg., Pittsburgh, Pa.
Alcoa Aluminum and its alloys in every commercial form—flat and corrugated sheet, castings, forgings, tubing including streamline, bolts, screws, rivets, wire, rod, bar, fuel tanks, Lynite Pistons and Connecting Rods.

BENDIX BRAKE COMPANY
South Bend, Indiana

Subsidiary of
Bendix Aviation Corporation
High Pressure Wheels and Brakes
Streamline Wheels and Brakes
Pneudraulic Shock Struts
A-N Standard Pilot Seats
Beaching Gear Wheels Tail Wheels

HASKELITE MANUFACTURING CORPORATION

120 So. La Salle St., Chicago, Ill.
Haskelite—blood albumin glued aircraft plywood. Insulated Haskelite Plywood for cabin linings. Plymetl, plywood with metal faces for cabin linings and baggage compartments. Geo. R. Meyer-cord, Pres.; J. R. Fitzpatrick, V.-Pres.; C. E. Scott, Mgr., Aircraft Division.

MACWHYTE COMPANY

Kenosha, Wisconsin
Aircraft Tie Rods
Streamline Square Round
with Terminal Assemblies
Geo S. Whyte, President
Jessel S. Whyte, V.-Pres. & Gen. Mgr.
R. G. Diehl, Sales Engineer

THE OHIO SEAMLESS TUBE COMPANY

Shelby, Ohio
Cold Drawn Seamless Tubing in Carbons and Alloy Steels
Particular attention given Aircraft seamless tubing to U. S. Government Specifications.

JOHN A. ROEBLING'S SONS COMPANY, Trenton, New Jersey

Aircraft Wire, Strand, Cord, Thimbles, Ferrules, Locking and Serving Wire, Welding Wire, Control Cables, Ignition Cables, Electrical Wires and Cables.
Horace E. Thorn
Aeronautical Representative
Catalog A-636

STEWART HARTSHORN COMPANY

250 Fifth Ave., New York City
Mfrs. of streamline and square section tie rods complete with end fittings for airplane external and internal bracing.
B. E. Bushnell, Director of Sales
J. M. Layng, Aeronautical Repre'tive

SUMMERILL TUBING COMPANY

Bridgeport, Montg. Co., Pa.
Mfrs. and warehouseers of Seamless Steel Tubing for Aircraft Industry made to Govt. specification. Round, Streamline and Special Shapes, including Corrosion-resisting steels. S. L. Gabel, Vice-President, N. H. Wolf, General Manager.

**AIRPORT
EQUIPMENT**



**AMERICAN GAS AC-
CUMULATOR COMPANY**

Box 38

Elizabeth, New Jersey

Exclusive Distributors of
AGA, BBT, and SPERRY
Airport and Airway
Lighting Equipment

JULIEN P. FRIEZ & SONS, Inc.
Baltimore St. and Central Ave.
Baltimore, Maryland
Division of Bendix Aviation Corp.
Airport Weather Instruments
Lucien L. Friez, President
John Meagher, Vice-President

GENERAL ELECTRIC CO.
Schenectady, N. Y.

Complete airport- and airway-lighting
equipment including beacons,
superchargers for Aircraft En-
gines, Complete Airport
Lighting Equipment



**WESTINGHOUSE ELECTRIC AND
MANUFACTURING CO.**

Manufacturers of a complete line of
airport and airway lighting equipment;
motors and control; arc welding equip-
ment; electric heat treating furnaces;
Micarta pulleys, fairleads, hinges, and
cabin lining for aircraft.

Offices in all principal cities

**ELECTRICAL
EQUIPMENT**

**THE ELECTRIC STORAGE
BATTERY CO.**

Philadelphia, Pa.

For Airplane Cranking, Lighting,
Ignition, Radio
Photography, etc.
Exide
John R. Williams,
President; H. B.
Gay, Vice-Pres.
R. C. Norberg, Vice-Pres. & Gen. Mgr.

THE LEECE-NEVILLE COMPANY
5363 Hamilton Ave., Cleveland, Ohio

Electrical Starting and
Lighting Systems
Voltage Regulators
for Airplanes

B. M. Leece, President
P. H. Neville, Vice-President
Geo. S. Cole, Secy. and General Mgr.

**ENGINE PARTS,
COMPONENTS AND
ACCESSORIES**

THE B. G. CORPORATION

136 West 52nd Street
New York City

B. G. Mica Aviation Spark Plugs
B. G. Shielded Spark Plugs
August Goldsmith, President
George M. Paulson, Chief Engineer

ECLIPSE AVIATION CORP.

East Orange, N. J.

Starters, Generators,
Radio Power Equipment,
Fuel Flometers,
Automatic Propeller Hubs, etc.
Charles Marcus, President
Raymond F. Lansing, Vice-Pres.
Edward E. Lewis, Sec.-Treas.

NORMA-HOFFMAN BEARINGS CORPORATION, Stamford, Conn.

New York Cleveland Detroit
Chicago Pittsburgh Cincinnati

Precision Ball**Roller and Thrust Bearings**

W. M. Nones, Pres. and Treas.; O. P. Wilson, Vice-Pres.; G. R. Bott, Eng. Mgr.; H. J. Ritter, Ass't Secy.

UNITED AIRCRAFT PRODUCTS, Inc.

Dayton, Ohio

Mfr's of AN Standard Aircraft Parts and Accessories

Specialists in Aircraft Fuel System and Power Plant Equipment

H. M. Hiester, General Manager

R. G. Dykeman, Chief Engineer

Jos. G. Lehman, Treasurer

THE VELLUMOID COMPANY

Worcester, Mass. - - - Detroit, Mich.

Vellumoid Sheet Packing and Vellumoid Gaskets

G. C. Beals, Treasurer and Gen. Mgr.

W. W. Webster, Ass't Treasurer

C. S. Livingstone, Sales Manager

WYMAN-GORDON COMPANY

Guaranteed Forgings

Worcester, Mass. Harvey, Ill.
Aviation Division: Worcester, Mass.

Manufacturers of

Crankshafts, Connecting Rods, Propeller Hubs, Cams, Gears, Pistons, and other vital forgings for Aircraft Engines

FLARES AND SIGNALS**INTERNATIONAL FLARE SIGNAL CO.**, Tippecanoe City, Ohio

Airplane Flares and Signals

Complete line up to 400,000 c.p. (3 min.) Parachute Flares operated electrically by remote control, and including pistol operated types up to 135,000 c.p. (1 minute) Parachute Flares. Approved by Department of Commerce.

Send for complete descriptive catalog

INSTRUMENTS**ELGIN NATIONAL WATCH COMPANY.** Aircraft Instrument Division
Elgin, Illinois

Tachometers, Altimeters, Clocks, Compasses, Airspeed, Fuel and Oil Pressure Gauges, Ice Warning Indicators, Thermometers, Pilots' Watches, Electrically and Pistol Operated Flares.

PIONEER INSTRUMENT CO., Inc.

(Subsidiary of Bendix Aviation Corp.)

Brooklyn, N. Y. Los Angeles, Calif.

European Representative

M. Calderara

Paris, France

Aircraft Instruments and Accessories

SPERRY GYROSCOPE CO., Inc.

Brooklyn, N. Y.

Manufacturers

Gyroscopic Aircraft Instruments

Airport and Airway Lighting Equipment

**PARACHUTES****IRVING AIR CHUTE CO., Inc.**

1670 Jefferson Ave., Buffalo, N. Y.

Mfrs. of parachutes used as Standard Equipment by 36 different Governments. Buffalo, N. Y.; Glendale, Cal.; Ft. Erie, Ont.; Letchworth, Eng.

Cable Address:

"Irvin Buffalo, N. Y." and "Irvin Letchworth England."

PROPELLERS

HAMILTON STANDARD PROPELLER COMPANY, East Hartford, Conn.

Subsidiary

United Aircraft and
Transport Corporation

Adjustable and Controllable Pitch
Airplane Propellers

Raycroft Walsh, S. A. Stewart,
President Sec.-Treas.

RADIO EQUIPMENT

AIRCRAFT RADIO CORPORATION

Aircraft Radio Equipment

Main Office and Airport at

Boonton, N. J.

**AMERICAN TELEPHONE AND
TELEGRAPH COMPANY**
and Associated Companies

Bell System Communication Services
Any Bell System Business

Office or General Commercial Manager

Long Lines Department

32 Sixth Avenue New York City

"STANDARDIZED"

Radio Receiving and Transmitting

Units for Aircraft and Airports

Western Electric

Commercial Department

195 Broadway, New York, N. Y.

TIRES

THE B. F. GOODRICH RUBBER CO.

Akron, Ohio Los Angeles, Calif.

Mfrs. Silvertown high and low pressure
Tires, Tailwheels, Rubber Tubing,
Shock Cord, Matting, Grommets,
Gasoline and Radiator Hose, Head-
phone Cords, Engine Mounts and
Special Molded Goods, De-Icers and
Abrasion Shoes.

James S. Pedler, Aeronautical Sales

. DIVISION III .

AIR TRANSPORT, OPERATORS, AND REFINERS
OF FUELS-LUBRICANTSAIR TRANSPORT
OPERATORS

AMERICAN AIRWAYS, Inc.
122 East 42d Street, New York, N. Y.
Passengers—Mail—Express
Coast to Coast—Canada to the Gulf
*Have our Business Travel Planning
Service arrange your transportation*
Reservations at Leading Hotels, Travel
Bureaus or any Postal Telegraph Office

PITTSBURGH AVIATION INDUSTRIES CORP., Divisions, Pennsylvania Airlines, Inc., Penn School of Aviation. Branches at
Pittsburgh: Butler Airport
Curtiss-Bettis Airport. Harrisburg Airport. Aerial Services of All Kinds
Main Office:
Allegheny County Municipal Airport,
Pittsburgh, Pa.

T W A "The Lindbergh Line"
**FASTEST SERVICE SHORTEST
ROUTE—COAST TO COAST**
Passengers—Mail—Express
Reservations at leading hotels, travel
bureaus, any Penna. R.R., Postal
Telegraph, Western Union, Greyhound
Bus or T W A office.
Transcontinental & Western Air, Inc.

REFINERS OF FUELS
AND LUBRICANTS

SOCONY-VACUUM CORPORATION
26 Broadway New York, N. Y.
Mobiloil Aero Oils
Socony Gasolines Mobilgas

**STANDARD OIL COMPANY
OF CALIFORNIA**
225 Bush St., San Francisco, Calif.
Aviation Petroleum Products
Stanavo Aviation Gasoline
Stanavo Aviation Engine Oil
Stanavo Rocker-Arm Grease
S. S. Chadderton, Manager
Aviation Department

**STANDARD OIL COMPANY
(Indiana)**
910 S. Michigan Ave., Chicago, Ill.
Fuel and Lubricants; Stanavo Aviation
Gasolines, Stanavo Aviation Engine
Oils and Greases
Edward G. Seubert, President
Allan Jackson, Vice-President
Amos Ball, General Mgr. Sales

**STANDARD OIL COMPANY
OF NEW JERSEY**
26 Broadway New York, N. Y.



STANAVO
AVIATION
PRODUCTS

THE TEXAS COMPANY
135 East 42nd St., New York City
Offices in Principal Cities



Texaco Aviation Gasoline
Texaco Airplane Oils
Texaco Marfak Greases

. DIVISION IV .

EXPORTERS, PUBLISHERS AND MISCELLANEOUS

ART WORK

JOHN MACGILCHRIST

369 Pacific Street Brooklyn, N. Y.

*Perspectives of airplanes and airports
drawn from blueprints*

Water colors and oils for sales promotion campaigns. Etchings and lithographs on aeronautical subjects.

CREDIT SERVICE

NATIONAL CREDIT OFFICE

Aeronautical Division

East Ohio Gas Building

Cleveland, Ohio

Operating as the

Official Credit Department for

The Aeronautical

Chamber of Commerce

EXPORTERS

BARR SHIPPING CORPORATION

25 Beaver St., New York City

Specializing in

Boxing, Shipping, Insuring Export

Planes, Motors, etc.

Pioneers in Export Service to Aircraft
Manufacturers

CURTISS-WRIGHT EXPORT CORPORATION, 29 W. 57th St., N. Y. C. A Division of Curtiss-Wright Corporation. Sales and distributors of planes, motors and all types of aeronautical equipment in foreign countries. C. W. Webster, Pres.; J. S. Allard, Vice-Pres.; Wm. F. Goulding, Vice-Pres.; R. R. Reger, Sec.

Cable Address "Aeroexco"

UNITED AIRCRAFT EXPORTS, Inc.

230 Park Ave., New York, N. Y.

Cable Address: "Unitedair"

Export Representatives for:

Boeing, Chance Vought, Sikorsky and
Stearman Airplanes

Pratt & Whitney Engines and

Hamilton Standard Metal Propellers

PHOTOGRAPHIC

EQUIPMENT

EASTMAN KODAK COMPANY

Rochester, N. Y.

Aerial Photographic Materials
and Supplies

 PUBLISHERS

AVIATION

E. P. Warner
Editor
Estab. 1916

The authority on Aircraft, Air Transport, and Military Aviation. Member Audit Bureau of Circulation.

McGraw-Hill Publishing Co.
330 W. 42nd St. New York

U. S. AIR SERVICES

Feature Aeronautical Magazine
Commercial and Military
Best and oldest monthly in its field

Transportation Building,
Washington, D. C.

Earl N. Findley, *Editor*

\$3.00 a year \$5.00 for two years
Beginning 15th Year of Publication

INDEX

A

- A*, see Waco Aircraft Co.
 Abbot, Charles G., 480
 A.B.C. Motors, Ltd., 215
 Accessories, 367-378; directory of manufacturers, 449-450, 486-489
 Accidents, 435-438
 Adams, Charles Francis, 51
 Adams, Porter, 481
 Adria Aero Lloyd, 219
 Advertising, 87
 Aerial Communication, Ltd., 234
 Aerial Service Company of Siam, Ltd., 228
 Aerial service operations, 10-12, 121-127; directory of operators, 449; *graph*, 10; statistics, 121-122, 127, 417
 Aero Digest, a publication, 452
 Aero Espresso Italiana, 219
 Aero Osakeyhtiö, 204, 229
 Aero-St. Gallen, 232
 Aeronautical Chamber of Commerce of America, Inc., 9, 92, 141, 150; Accessory and Material Section, 143, 367-368; Air Transport Section, 21-22, 26-28, 30, 368; Airport Section, 110-112; Committees, 447-448; Educational Committee, 172; Engine Manufacturers Section, 143, 326; Fuels and Lubricants Section, 322; Legal and Legislative Research Service, 157; members, 447-452
 Aeronautical Corporation of America, 244, 247, 326; *Aeronca C-3*, 271; *E-113A*, 333
 Aeronautical Engineering, a publication, 452
 Aeronautical Expositions Corp., 452
 Aeronautical industry, 1-8, 9-16
 Aeronautical Patents and Design Board, 146
 Aeronautics Branch, Dept. of Commerce, 22, 98, 141-147; airways, 144-146; appropriations, 431-432; miles flown, 13, 417; organization, 477; schools, 478-479
 Aeronautics Trade Division, 141
Aeronca, see Aeronautical Corporation of America
 Aeroplani Caproni, 220
 Aeroposta Argentina, S. A., 187
 Aëropostale, see Compagnie Générale Aëropostale
 Aeropot, see Aerial Communication, Ltd.
 Aerovias Centrales, S. A. 176, 186
 Air Corps, U. S. Army, 61-68; accidents, 68, 442; appropriations, 4-8, 61-62, 431-432; equipment, 62-66; five year program, 61; miles flown, 13, 417; organization, 472-475; personnel, 429; procurement, 438-439; Reserve stations, 474; schools, 474
 Air Ferries, Ltd., 47
 Air Law Review, a publication, 452
 Air lines, see Air transport
 Air mail, 2-4, 10, 29-30; appropriations, 4-6, 431-432; F. A. M. routes, 428-429; *graph*, 6; operations, 426-427; post office officials, 482; postage rates, foreign, 430
 Air Orient, 207, 217, 228
 Air Reduction Sales Co., 377
 Air Traffic Conference, see Aeronautical Chamber of Commerce of America, Inc.
 Air transport, 2-8, 9-10, 17-48; directory of operators, 448, 490; equipment, 20; Europe, 193-234; *graph*, 7, 33, 35; Latin America, 174-190; maintenance, 21-24; night flying, 18; noted passengers, 49-59; rates, 26, *graph*, 15; summary of operations, 417, 422; ticket offices, 28
 Air Transportation, a publication, 452
 Air Union, 207, 232
Airbus, see Bellanca Aircraft Corp.
 Aircraft Age, a publication, 452
 Aircraft Products Corp., 331
 Aircraft Radio Corp., 368, 369-370
 Airplane designs:
 Aeronautical Corporation of America, 271
 American Airplane and Engine Corp., 257
 Amphibions, Inc., 272
 Bellanca Aircraft Corp., 258, 273, 274
 B/J Aircraft Corp., 296-298
 Boeing Airplane Co., 259, 299-303
 Curtiss Aeroplane and Motor Co., Inc., 304-310

- Curtiss-Wright Airplane Co., 260, 261, 275, 276, 311
 Ford Motor Co., 262
 General Aviation Mfg. Corp., 312, 313
 Great Lakes Aircraft Corp., 277, 278
 Keystone Aircraft Corp., 280, 314-316
 Kreider-Reisner Aircraft Co., 281, 282
 Lockheed Aircraft Corp., 263, 264, 283
 Loening, Grover, Aircraft Co., Inc., 284
 Martin, Glenn L., Co., 317
 Pitcairn Aircraft, Inc., 265
 Sikorsky Aviation Corp., 266, 267, 288
 Stearman Aircraft Co., 268, 289
 Stinson Aircraft Corp., 269, 290
 Vought, Chance, Corp., 318, 319
 Waco Aircraft Co., 291-294
 Airplanes, designs, 257-319; directory of manufacturers, 448, 484-485; *graph*, 14; production, 13-14, 247-255, 418, 420, *graph*, 11; sales, 418, 420; specifications, 270, 295; technical development, 237-247
 Airports, 105-119; Alaska, 469-470; directory of airports, 449, 458-469; expenditures, 105-106; *graph*, 13; managers, 458-469; ratings, 108-110; seaplane anchorages, 470-472
 Airships, 6, 79-87; Merchant Airship Bill, 6, 79
 Airways, 144-146
 Airwork, 203
 Airwork, Ltd., 213
 Akron, airship, 76, 79, 80-82, 250, 328, 381
 Akron, O., airport, 108
 Akron Times-Press, 155
 Akta. Acrotransport, 229
 Alameda, Cal., airport, 116, 119
 Alaska, 174; airports, 469-470
 Alaskan Airways, Inc., 34, 174
 Albatros Flugzeugwerke G.m.b. H., 211
 Albee, Dr. Fred H., 58
 Albert, King of the Belgians, 54, 92
 Albrecht, Fritz, 97, 383
 Alcock, Capt. John, 89, 91
 Alexander, J. Don, 479
 Alfa-Romeo, 220
 Allard, J. S., 447, 452
 Allison Engineering Co., 326-328
 Alpar, 232
Altair, see Lockheed Aircraft Corp.
 Aluminum Company of America, 240, 376
 American Airplane and Engine Corp., 246, 248, 328; *Pilgrim 100-A*, 257
 American Airways, Inc., 17, 18, 20, 24, 28, 32, 34, 36-39, 46, 49, 57, 152, 156, 246, 248, 382
 American Bar Association, 162
 American Committee for the Marking of Obstructions to Air Navigation, 110
 American Gas Accumulator Co., 368, 373
 American La France and Foamite Corp., 378
 Ames, Joseph S., 480, 481
 Amphibions, Inc., 244, 248; *Privateer P-3B*, 272
 Amundsen, Roald, 97
 Anderson, Roy R., 482
 Anton, Archduke, 56
 Appropriations, governmental, 4-8, 431-432
 Arado Handelsgesellschaft m.b.H., 211
 Argentina, 180
 Argus Motorenengesellschaft m.b.H., 211
 Arias, Dr. Harmodio, 54
 Arkansas Gazette, 152
 Army, see Air Corps, U. S. Army
 Arrow Aircraft, Ltd., 215
 Asahi Teiki Koku-kai, 221
 Asplundh, E. T., 452, 479
 Associated Press, 151
 Atlanta, Ga., airport, 114
 Australia, 193-195
 Austria, 195-196
 Austrian Air Traffic Co., see Oesterreichische Luftverkehrs, A. G.
 Autogiro, 16, 134, 135, 137, 243-244, 254; designs, 279, 285, 286, 287
 Autogiro Company of America, 244
 Aviation, a publication, 452
 Aviation Corporation, 32-34, 36, 44, 174, 246, 248, 328
 Aviation Country Club, 136-137, 475-476
 Aviation Engineering, a publication, 452
 Avions Bulté and Co., 196
 Avions et Moteurs Renard, 196
- ## B
- B4-A*, *B6-A*, see Keystone Aircraft Corp.
B-5, see Kinner Airplane and Motor Corp., Ltd.
 Baba, Eichiro, 98, 383
 Badger, H. Ralph, 480
 Bahamas, 180
 Bainbridge, Ga., airport, 117
 Balbo, Gen. Italo, 218
 Balchen, Bernt, 90, 91
 Balloon races, see Bennett, Gordon, International Balloon Race; National Balloon Race
 Baltimore, Md., airport, 114
 Bannister, Harry, 57
 Barbour, Henry E., 52
 Barnaby, Lt. Comdr. Ralph S., 139
 Barndt, Charles F., 479
 Barringer, Lewin B., 132
 Bayerische Motorenwerke A. G., 211
 Beardmore, William, and Co., Ltd., 215
 Beecroft, David, 482

- Belgian Aeronautic Construction Co., 196
 Belgium, 196-198
 Bell, Luther K., 447, 452
 Bell Telephone Laboratories, Inc., 368, 369
 Bellanca Aircraft Corp., 244, 248; *Airbus*,
 258; *Pacemaker*, 273; *Skyrocket*, 274
 Bemidji, Minn., airport, 117
 Bendix, Vincent, 482
 Bendix Aviation Corp., 370, 371, 374
 Bendix Brake Co., 374-375
 Bennett, Floyd, 90
 Bennett, Gordon, International Balloon
 Race, 86-87, 100, 383, 399
 Beretta, J. W., 481
 Berry Brothers, 377
 B. G. Corporation, 368, 370
 Bingham, Hiram, 51, 480
 Birmingham, Ala., airport, 108
 Birmingham News and Age-Herald, 152
 Bishop, Lieut. John H., 100, 382, 398
 B/J Aircraft Corp., 244, 248; *OJ-2*, 297;
 XFJ-2, 296; *YIP-16*, 298
 Blair, R. L., 100
 Blee, Harry H., 477, 481
 Blythe, Cal., airport, 117
 Board of Surveys and Maps, 147
 Boardman, Russell N., 90, 101, 151
 Bochkon, John, 98, 383
 Boeing Air Transport, Inc., 36, 45
 Boeing Airplane Co., 244, 246, 248-250;
 247, 259; *F4B-3*, 302; *F4B-4*, 301;
 P-12F, 302; *XF6B-1*, 300; *XP-936*,
 299; *Y1B-9A*, 303
 Boeing School of Aeronautics, 122
 Boileau, Gerald J., 52
 Bolivia, 180-182
 Bonnett, Warrant Officer, 90, 101
 Boocock, Kenyon, 137
 Bossoutrot, Lucien, 102, 381
 Boston, Mass., airport, 115, 116
 Boston Evening Transcript, 154
 Bostwick, Mary E., 153
 Boutelle, Richard S., 163
 Bowen Air Lines, Inc., 39
 Bradley, S. S., 447, 479
 Bradley Polytechnic Institute, 167
 Braniff Airways, Inc., 39
 Brazil, 182
 Brazil Aircraft Corp., 250
 Breeze Corporation, 368, 370
 Briggs, Dr. L. J., 477
 British Honduras, 183
 British Salmson Aero Engines, Ltd., 215
 Brock, Dr. John D., 132
 Brookhart, Smith W., 51
 Brooklyn Times, 155
 Brooks, R. L., 136
 Brossy, Frederick A., 90
 Broun, Heywood, 57
 Brown, Sir Arthur Whitten, 89, 91
 Brown, Walter F., 51, 482
 Brukner, Clayton J., 447, 452, 479
 Brunswick, Ga., airport, 117
 Buck, Robert, 132
 Budwig, Gilbert G., 477
 Buffalo, N. Y., airport, 108, 117
 Bulgaria, 198
 Bulow, William J., 52
 Burbank, Cal., airport, 119
 Bureau of Aeronautics, U. S. Navy, 69-
 78, 322; accidents, 70; appropriations,
 76, 431-432; equipment, 70; miles
 flown, 13, 417; organization, 481-482;
 personnel, 441; procurement, 440
 Bureau of Standards, 146
 Burlington, N. C., airport, 117
 Bushman, Francis X., 57
 Bushnell, Lieut. Wilfred, 100, 399
 Butler, C. A., 94
 Byrd, Rear Adm. Richard E., 90, 92, 481
 Byrns, Joseph W., 52
- C
- C*, see Waco Aircraft Co.
C3R, see Stearman Aircraft Co.
C-5, see Kinner Airplane and Motor
 Corp., Ltd.
 California Institute of Technology, 86,
 166, 167
 Camden, N. J., airport, 115, 118
 Campbell, Sir Malcolm, 57
 Campbell, William T., 135
 Canada, 178-179
 Canadian Airways, Ltd., 178
 Canadian Colonial Airways, Ltd., 178
 Canfield, Dr. Norton, 132
 Cannon, Clarence, 52
 Cantieri Aeronautici Bergamaschi, 220
 Cantiero Riuniti Adriatico, 220
 Carnegie Institute of Technology, 166
 Carpentier, Georges, 57
 Carriers, aircraft, 69, 72-74
 Carroll, Earl, 57
 Carroll, Sue, 57
 Case School of Applied Science, 167
 Cautley, John R., 452
 Cederleaf, Fred W., 482
 Celler, Emanuel, 52
 Century Air Lines, Inc., 32
 Century Pacific Lines, Ltd., 32
Challenger, see Wright Aeronautical Corp.
 Chamberlin, Clarence, 381
 Chambers, Reed M., 447
 Champion Spark Plug Co., 134, 368
 Chapin, Roy D., 51
 Cheney Award, 381
 Chicago, Ill., airport, 116, 118
 Chicago Daily News, 153
 Chicago Tribune, 153

- Childs, Geoffrey S., 447
 Chile, 183-184
 China, 199-200
 Chinese National Aviation Corp., 199
 Christensen, Capt. Friedrich, 95
 Chronology, 381-383
 Cidna, *see* Compagnie Internationale de Navigation Aérienne
 Cierva, Juan de la, 135-136, 381
 Cincinnati, O., airport, 115
 Cincinnati Post, 155
 Cintas, Oscar, 54
 Cislér, Stephen A., 482
 Civilian Aircraft Co., Ltd., 215
 Clague, Frank, 52
 Clancy, Robert H., 52
 Clark, Charles C., 483
 Classa, *see* Concesionaria de Lineas Aereas Subvencionadas, S. A.
 Claudel, Paul, 54
 Clemson Agricultural College, 172
 Cleveland, O., airport, 119
 Cleveland Pneumatic Tool Co., 375
 Cleveland Press, 155
 Coast Guard, U. S., 13, 147, 417
 Coburn, Frederick G., 32, 447, 452
 Coca-Cola Co., 135
 Codos, Paul, 381
 Cohu, La Motte T., 32, 34
 College of the City of Detroit, 166, 167
 College of William and Mary, 168, 169-170
 Collier Trophy, 330, 381
 Colombia, 184
 Columbus Citizen, 155
 Commuter, *see* Keystone Aircraft Corp.
 Compagnie Générale Aéropostale, 180, 182, 183, 188, 189, 190, 206, 207, 229
 Compagnie Internationale de Navigation Aérienne, 201, 207, 216, 226, 227, 233
 Compañía Mexicana de Aviación, S. A., 186
 Compañía Nacional Cubana de Aviación, S. A., 34, 174
 Compañía Nacional de Aviación, 183, 185
 Compañía Portuguesa de Aviação, 227
 Comper Aircraft Co., Ltd., 215
 Concesionaria de Lineas Aereas Subvencionadas, S. A., 228
 Condor, *see* Curtiss-Wright Airplane Co.
 Condor Syndicate, Ltd., 100, 180, 182
 Conneaut, O., airport, 117
 Conqueror, *see* Wright Aeronautical Corp.
 Consolidated Aircraft Corp., 244, 250
 Continental Aircraft Engine Co., 326, 328; R-690, 334
 Continental Motors, 328
 Cook, Arthur B., 480, 481
 Cooke, Harte, 482
 Cooper, Gary, 57
 Cooper, Henry B., 154
 Cooper, Ray, 481
 Cord, E. L., 32, 34, 44
 Cord Corporation, 32, 246, 255, 328
 Cornell University, 171
 Corporación Aeronautica de Transportes, S. A., 186
 Costa Rica, 184
 Costruzioni Meccaniche Aeronautiche, 220
 Cosyns, Max, 382
 Courtney, Capt. Frank, 97
 Crawford, J. M., 482
 Cross-License Agreement, *see* Manufacturers Aircraft Association, Inc.
 Crosser, Robert, 79
 Crosthwaite, S. W., 477
 Cuba, 184-185
 Curtis, Charles, 92
 Curtiss Aeroplane and Motor Co., Inc., 244, 246, 250, 253, 368, 372; F9C-2, 306; F11C-2, 305; O-39, 310; P6-E, 307; Raven YO-40, 309; Shrike YA-8, 308; Swift XP-934, 304
 Curtiss-Wright Air Terminals, 127
 Curtiss-Wright Airplane Co., 244, 246, 250-252; 16-E, 275; Condor T-32, 260; Kingbird, 261; Osprey, 311; Speedwing, 276
 Curtiss-Wright Corp., 34, 122, 124, 184, 199, 246, 250, 253, 331
 Cyclone, *see* Wright Aeronautical Corp.
 Czechoslovak Air Traffic Co., 201
 Czechoslovakia, 201-202
- ## D
- Daily Oklahoman, 156
 Dallas, Tex., airport, 115, 119
 Dallin Aerial Surveys, 127
 Danish Air Transport Co., Ltd., *see* Danske Luftfartselskab, A/S.
 Danske Luftfartselskab A/S., 202
 Dassy, 196
 Davis, James J., 51
 Davis, Walter C., 479
 Davis Aircraft Corp., 252
 Davison, F. Trubee, 54, 472, 481
 Defender, blimp, 84, 85
 De Havilland Aircraft Co., 195
 Delco Aviation Corp., 368
 Delhi Flying Club, 217
 Dempsey, Jack, 57
 Denmark, 202-203
 Dept. of Commerce, *see* Aeronautics Branch, Dept. of Commerce
 De Roy, Dr. Felix, 135
 Deruluft, 204, 208, 222
 Des Moines, Iowa, airport, 117
 Detroit, Mich., airport, 108
 Detroit Free Press, 154

Detroit News, 154
 Deutsche Luft Hansa, 100, 199, 208-211, 216, 225, 229, 232, 233
 Deutsche Verkehrsflug A. G., 208
 Dexter, Capt. Julian S., 134
 Dickinson, H. C., 482
 Dill, Clarence, 51
 Diplomatic Service of the U. S., 477; to the U. S., 477
D L-1, see Lockheed Aircraft Corp.
 Doe, Thomas B., 447
 Doherty, Henry L., 137
 Dominican Republic, 185
 Doolittle, Maj. James H., 90, 101, 102, 372, 382, 383, 481
 Doret, Marcel, 102
 Dornier *Do-X*, 95, 382
 Dornier Metallbauten G.m.b.H., 211
 D'Orsay, Fifi, 57
 Douglas, Ariz., airport, 108
 Douglas, Donald, 479
 Douglas Aircraft Co., Inc., 244, 252
 Dow Chemical Co., 377
Do-X, see Dornier *Do-X*
D R-980, see Packard Motor Car Co.
Duckling, see Loening, Grover, Aircraft Co., Inc.
 Dunwoody, Halsey, 447
 Durand, William F., 480

E

E-113A, see Aeronautical Corporation of America
 Earhart, Amelia, 91-92, 132, 382, 383, 481
 East Hartford, Conn., airport, 115
 East Millinocket, Maine, airport, 117
 East St. Louis, Ill., airport, 108
 Eastern Air Transport, Inc., 20, 24, 28, 32, 34, 39-40, 50, 54, 57, 58, 251, 383
 Eaton, James M., 447
 Eaton, Robert, 139
 Eckel, Capt. Earle S., 135
 Eckener, Dr. Hugo, 381
 Eclipse Aviation Corp., 368, 371, 375
 Ecuador, 185
 Editors, see Newspapers
 Edo Aircraft Co., 376
 Education, aeronautical, 165-172; tabulation of courses, 443-444
 Edward Albert, Prince of Wales, 56, 231
 Egypt, 203
 El Paso, Tex., airport, 108
 El Salvador, 185
 Electric Storage Battery Co., 368, 370
 Electrical equipment, 368-372; directory of manufacturers, 487
 Elgin National Watch Co., 368

Engine designs:

Aeronautical Corporation of America, 333
 Continental Aircraft Engine Co., 334
 Kinner Airplane and Motor Corp., Ltd., 335-338
 Lycoming Mfg. Co., 339, 340
 Packard Motor Car Co., 341, 342
 Pratt and Whitney Aircraft Co., 343-352
 Warner Aircraft Corp., 353, 354
 Wright Aeronautical Corp., 355-365
 Engineering, see Airplanes, technical development; Engines, technical development
 Engines, designs, 333-365; Diesel, 85, 330; directory of manufacturers, 448, 485; production, 15-16, 326-332, 419, 421, *graph*, 11; sales, 419, 421; technical development, 321-326
 England, see Great Britain
 Equipment, 377-378; directory of manufacturers, 487; electrical, 368-372; lighting, 372-373
 Espenlaub Flugzeugbau, 211
 Estonia, 203-204
 Eurasian Aviation Corp., 199
 Exports, 16, 422-425; directory of exporters, 448, 491; *graph*, 192
 Express, 28-29; *graph*, 37

F

F, F2, see Waco Aircraft Co.
F4B-3, F4B-4, see Boeing Airplane Co.
F9C-2, F11C-2, see Curtiss Aeroplane and Motor Co., Inc.
 Fairbanks, Douglas, 57
 Fairchild, Sherman M., 447, 452
Fairchild 22, 24, see Kreider-Reisner Aircraft Co.
 Fairchild Aerial Surveys, 127
 Fairchild Aviation Corp., 127, 246, 253
 Farm Flying Service, 124
 Farman Lines, see Société Générale de Transportes Aériens
 Faucett Aviation Co., 187, 188
 Fayetteville, N. C., airport, 117
 Fess, Simeon D., 51
 Fiat, 220
 Fieseler Flugzeugbau, 211
 Finland, 204-205
 Finnish Air Service Co., see Aero Osakeyhtiö
 Fishleigh, Walter T., 482
5-D, see Ford Motor Co.
 Five Year Program, see Air Corps, U. S. Army
FLB, see General Aviation Mfg. Corp.
 Fletcher, William G., 156

Flights, record, *see* Record flights
 Florez, Luis de, 137
 Flugzeugbau Max Gerner G.m.b.H., 211
 Flying schools, approved, 122, 478-479
 Focke-Wulf Flugzeugbau A. G., 211
 Fogg, Robert S., 124
 Fontaine, Lynn, 57
 Ford Hotels, 134
 Ford Motor Co., 252; 5-D, 262
 Foreign aeronautical development, 191-234
 Fort Wayne Journal Gazette, 153
 Fort Wayne News-Sentinel, 153
 Fort Worth, Tex., airport, 119
 Fort Worth Star Telegram, 156
 Foulois, Maj. Gen. Benjamin D., 62, 472, 480, 481
 France, 205-208
 Francis, Kay, 57
 Free, Arthur M., 52
 Fresno, Cal., airport, 114
 Friez, Julian P., and Sons, 368, 374
 Fuels, directory of companies, 449, 490

G

Galveston, Tex., airport, 117
 Gardner, George, 477
 Gardner, George E., 477
 Gardner, L. D., 447
 Garner, John Nance, 50-51, 52
 Gatty, Harold, 89, 90, 92, 95
 Gazley, Richard C., 477
 General Air Express, 28, 40, 41, 42, 44, 45, 152
 General Aircraft, Ltd., 215
 General Aircraft Co., Ltd., 195
 General Aviation Corp., 34
 General Aviation Mfg. Corp., 147, 244, 246, 248, 252; *FLB*, 312; *YO-27*, 313
 General Electric Co., 368, 373
 General Motors Corp., 34, 246, 252, 326
 Geneva, N. Y., airport, 117
 George, Prince, 56, 231
 George, Walter F., 52
 George, Willis, 137
 Georgia School of Technology, 166, 167, 171
 Georgian-American, 152
 Germany, 208-211
 Gibbons, Floyd, 57
 Gifford, Walter S., 58
 Gilbertsville, Pa., airport, 117
 Gilpin Air Lines, 40
Gipsy, *see* Wright Aeronautical Corp.
 Girier, Lt. Col. Andre L. F., 382
 Gisborne Air Transport Co., 225
 Glass, Carter E., 52
 Glendale, Cal., airport, 119
 Glenn, Otis F., 51

Gliding, 138-139
 Glover, W. Irving, 481, 482
 Goldendale, Wash., airport, 117
 Goodrich, B. F., Rubber Co., 371, 375
 Goodyear Tire and Rubber Co., 376
 Goodyear-Zeppelin Corp., 79, 82, 84, 87
 Gore, Thomas P., 52
 Gorski, Eddie, 91
 Gorst Air Transport, Inc., 40
 Goulette, Marcel, 381
 Gove, Chase C., 482
 Governmental policy, 4-8; *see also* Appropriations, governmental
Graf Zeppelin, airship, 80, 99-100, 381, 383
 Great Britain, 211-215
 Great Falls Tribune, 154
 Great Lakes Aircraft Corp., 244, 252; 2T-1A, 277; 2T-1E, 278
 Greece, 215-216
 Greek Air Transport Co., 215
 Griffin, Bennett, 95-96, 382
 Gronau, Capt. Wolfgang von, 96-98, 383
 Gross, Dr. Frank, 139
 Guatemala, 185
 Guggenheim, Daniel, Airship Institute, 85-86, 382
 Guggenheim, Daniel, Fund Committee on Elementary and Secondary Aeronautical Education, 172
 Guggenheim, Daniel, Fund for the Promotion of Aeronautics, 86
 Guggenheim, Mrs. Edmund, 173
 Guggenheim, Harry F., 480, 481
 Guldentops, 196

H

Hack, Franz, 97, 383
 Hadley, Ross, 132
 Hailey, Ida., airport, 117
 Haiti, 185-186
 Haizlip, James H., 102, 383
 Haizlip, Mac, 383
 Hale, Frederick, 51
 Hall-Aluminum Aircraft Corp., 252
 Haller-Flugzeuge, 211
 Hamilton Standard Propeller Co., 246, 368, 372
 Hammond, La., airport, 117
 Hanford's Tri-State Air Lines, Inc., 40
 Hanshue, Harris M., 34, 36, 447
 Hard, George W., 137
 Hardecker, John F., 482
 Harding, Ann, 57
 Hartford, Conn., airport, 115
 Haskelite Mfg. Corp., 376-377
 Hausner, Stanislaus F., 98, 382
 Hawaii, 216
 Hawks, Comdr. Frank M., 102, 381, 481

Hearst, William Randolph, jr., 57
 Heber Springs, Ark., airport, 117
 Hegenberger, Capt. A. F., 66
 Heinkel, Ernst, Flugzeugwerke G.m.b.H.,
 211
 Helium Board, 146
 Helm, Ennis, 156
 Henderson, Paul, 447
 Herndon, Hugh, 89, 90
 Hilsz, Maryse, 382
 Hingsburg, F. C., 477
 Hiron, Fred M., 482
 Hirth Motoren G.m.b.H., 211
 Hitchcock, Thomas, 57
 Homma, Kiyoshi, 98, 383
 Honduras, 186
 Hoover, J. Edgar, 59
 Hoover, Pres. Herbert, 92
 Hope, W. L., 382
 Hopfner, Theodor, 195
 Horine, M. C., 482
Hornet, see Pratt and Whitney Aircraft
 Co.
 Horr, Ralph A., 52
 Houston, Tex., airport, 108
 Howard, Roy, 57
 Hoyt, Palmer, 156
 Hoyt, Richard F., 34
 Hubbard, F. S., 479
 Hughesville, Pa., airport, 117
 Hungarian Air Traffic Co., see Magyar
 Legiforzalmi R. T.
 Hungary, 216-217
 Hunsaker, J. C., 447
 Hunter, Glenn, 57
 Hunter, John, 90
 Hunter, Kenneth, 90
 Hunter Airways, Inc., 40
 Hurlburt, W. B., 447, 452
 Hurley, Patrick J., 51
 Hurley-Townsend Corp., 368, 370
 Hurst, Fannie, 57
 Hurst, Ralph, 152
 Hutchinson, George, 98, 382

I

Ibañez, Carlos, 54
 Icaros, see Greek Air Transport Co.
 Ide, John J., 480
 Igoe, James T., 52
 Imperial Airways, Ltd., 54, 203, 211-213,
 217, 226, 228, 232, 233, 381
 Imperial Brass Mfg. Co., 377
 India, 217
 Indianapolis Star, 153
 Indianapolis Times, 153
 Industrial use of aircraft, 134-135
 Ingalls, David S., 54, 481
 Ingrid, Princess, 56

Inoshita, Tomoyoshi, 98, 383
 Insley, Robert, 402
 Instruments, 373-374; directory of manu-
 facturers, 488
 Insull, Martin, 152
 Insurance, directory of companies, 450
 Inter City Airlines, 40
 Inter-Island Airways, Ltd., 216
 International Congress of Trans-Oceanic
 Fliers, 218, 382
 International Flare and Signal Co., 377
 International News Service, 151-152
 International Zeppelin Transport Co., 80
 Iona National Airways, Ltd., 218
 Irimescu, Radu, 227
 Irish Air Lines, Ltd., 217
 Irish Free State, 217-218
 Irving, Livingston G., 124
 Irving Air Chute Co., 378
 Island Airways, 376
 Isotta Fraschini, 220
 Isthmian Airways, 187
 Italy, 218-221
 Ivanoff, Peter Dmitri, 184

J

Jacksonville, Fla., airport, 114
 Jacksonville, Ill., airport, 117
 Jacksonville Journal, 152
 Jacobs Aircraft Engine Co., 326, 328
 James, W. Frank, 52
 Japan, 221
 Japan Air Transport Co., see Nippon Koku
 Yusoo Kapushiki Kaisha
 Jeffers, Lamar, 52
 Jersey Journal, 155
 Jessel, George, 58
 Johnson, Amy, 94, 383
 Johnson, Carl, 132
 Johnson, L. McK., 194
 Johnson, Martin, 57
 Johnson, P. G., 36, 447, 452
 Johnson, Royal C., 52
 Johnsonburg, Pa., airport, 117
 Jones, Robert Tyre, 58
 Jones, Webster A., 156
 Jones, Wesley L., 51
 Joplin, Mo., airport, 117
 Jordan, Franklin, 154
 Jouett, John H., 200
 Journal of Air Law, a publication, 452
 Junkers Flugzeugwerk A.G., 211
 Junkers Luftverkehr Persia, 226
 Junkers Motorenbau G.m.b.H., 211

K

K-3, see Kellett Autogiro Corp.
 K-5, see Kinner Airplane and Motor
 Corp., Ltd.

- Kane, Helen, 57
 Kansas City Star, 154
 Kean, Hamilton F., 52
 Keller, Helen, 57
 Kellett Autogiro Corp., 244, 252; *Autogiro K-3*, 279
 Kelly, Clyde, 52
 Kendrick, John B., 51
 Kennedy, Madge, 57
 Kennedy, Martin J., 52
 Keystone Aircraft Corp., 244, 246, 253; *B4-A*, *B6-A*, 314; *Commuter*, 280; *O2L*, 315; *OL-9*, 316
 King, Henry, 132
Kingbird, see Curtiss-Wright Airplane Co.
 King's Cup Race, 382
 Kinner Airplane and Motor Corp., Ltd., 326, 328; *B-5*, 336; *C-5*, 338; *K-5*, 335; *R-5*, 337
 K. L. M., see Koninklijke Luchtvaart Maatschappij voor Nederland en Kolonien
 K. N. I. L. M., see Koninklijke Nederlandsch-Indische Luchtvaart Maatschappij
 Kohler Aviation Corp., 40
 Koninklijke Luchtvaart Maatschappij voor Nederland en Kolonien, 203, 207, 217, 222-223, 228, 229
 Koninklijke Nederlandsch-Indische Luchtvaart Maatschappij, 224-225, 229
 Kreider-Reisner Aircraft Co., Inc., 244, 246, 253; *Fairchild 22*, 281; *Fairchild 24*, 282
 Kvale, Paul J., 52
- L**
- LaBaie, A. J., 477
 La Crosse, Wis., airport, 117
 Lafayette, 172
 La Guardia, Fiorello H., 52
 Landing gear, see Undercarriage
 Landis, Reed, 481
Langley, carrier, 69
 Lankford, Jesse W., 477
 Lares, 227
 Larkin Aircraft Supply Co., Ltd., 193, 195
 Larsen, William W., 52
 Las Vegas, Nev., airport, 114
 Latin America, 173-190
 Latvia, 222
 Law, state, 157-163; tabulation, 432-433; taxation, 159-160, 434
 Lawrence, Charles L., 92, 447, 452, 481
 Lawrence, Kan., airport, 117
 Lawrence, L. W., 477
 Lawton, Okla., airport, 117
 Le Brix, Joseph, 102
 Lee, Clyde A., 98, 383
 Lees, Walter E., 90
 Legislation, see Law, state
 Lehigh University, 170
 Leichtflugzeugbau Klemm G.m.b.H., 211
 Lenz, Sydney, 57
 Leroy, A. R., 59
 Lewis, George W., 480, 481, 482
 Lewiston, Ida., airport, 117
Lexington, carrier, 69, 72
 Liberal, Kan., airport, 117
 Lienesch, C. F., 481
 Light, Dr. R. U., 130
 Lighting equipment, 372-373; directory of manufacturers, 487
 Lindbergh, Col. Charles A., 52, 91, 480, 481
 Lindsay, Sir Ronald, 54
 Linea Aerea Nacional (Chile), 183
 Linea Aerea Nacional (Peru), 188
 Linea Aviación Comerciales Venezolanas, 189
 Lineas Postales Aereas Espanolas, 229
 Lloyd Aereo Boliviano, 180
 Lockheed Aircraft Corp., 244, 253-254; *DL-1*, 263; *Altair*, 283; *Orion*, 264
 Loening, Grover, 447
 Loening, Grover, Aircraft Co., Inc., 254; *Duckling*, 284
 Londos, Jim, 57
 Longacre, Dr. R. F., 477
 Longworth, Mrs. Alice Roosevelt, 57
Los Angeles, airship, 76, 79
 Lot, see Polski Linje Lotnicze
 Louisville, Ky., airport, 114
 Louisville Courier-Journal, 154
 Louisville Times, 154
 Lowe, Edmund, 57
 Lowe, Edward H., jr., 174
 Luckner, Count Felix von, 57
 Ludington Airlines, Inc., 24, 28, 41, 57
 Luftschiffbau Zeppelin G.m.b.H., 211
 Lycoming Mfg. Co., 246, 324-326, 328; *R-680*, 339; *R-680-BA*, 340
 Lytton, Earl of, 56
- M**
- Maas, Melvin W., 53
 McAdoo, William Gibbs, 54
 McClean, Gerald D., 155
 McClintic, James V., 52
 McCormick, May, 152
 MacCracken, William P., jr., 480
 MacDonald, Jeannette, 57
 MacDonald, Ramsay, 56
 Macfadden, Bernarr, 57
 Mackay Trophy, 62
 McKee, Frank M., 447
 McKee, John H., 59
 McLaglen, Victor, 58

- McLeod, Clarence J., 52
 McMillan, Thomas S., 52
 McNamee, Graham, 57
 McNary, Senator, 79
 McNeill, G. G., 154
 Macon, airship, 76, 79, 80-82, 116, 326
 McSwain, John J., 52
 Macwhyte Company, 376
 Madison, Helene, 57
 Magazines, aeronautical, foreign, 453-454;
 U. S., 452
 Magyar Legiforgalmi R. T., 216
 Mamer Air Transport, 41
 Manchoukuo Air Traffic Co., Ltd., 200,
 222
 Manfred Weiss Airplane and Motor Mfg.
 Co., 217
 Manning, L. B., 447, 452
 Manufacturers Aircraft Association, Inc.,
 479-480; members, 480
 Mara, W. A., 479
 Marcus, Charles, 447, 452
 Marie, Queen, 54
 Marine Corps, U. S., 13, 69, 70, 185;
 flying fields, 481; personnel, 441
 Marriott, J. S., 477
 Marsalis, Frances, 382
 Marshal, Young, 199
 Marshall, R. C., 447
 Marshall, W. Fiske, 477
 Martin, Glenn L., 479
 Martin, Glenn L., Co., 176, 244, 254;
 XB-907, 317
 Martin's Aircraft Works, 215
 Martz Airlines, 41-42
 Marvin, Charles F., 480, 481, 483
 Mason, George, 154
 Massachusetts Institute of Technology, 167,
 171
 Materials, 376-377; directory of manufac-
 turers, 449-450, 486-489
 Mattern, James, 95-96, 382
 Maybach Motorenbau G.m.b.H., 211
 Mayo, William B., 447
 Mead, James M., 30, 53
 Mellon, Andrew W., 91
 Memphis, Tenn., airport, 115
 Menth, Joseph, 482
 Merchant Airship Bill, *see* Airships
 Messerschmitt Flugzeugbau G.m.b.H., 211
 Metallurgical Laboratories, Inc., 377
 Mexico, 176, 186
 Mexico, Mo., airport, 117
 Miami, Fla., airport, 116, 178
 Michigan College of Mining, 172
 Mid-Continent Air Express, Inc., 36
 Military aeronautics, 4-8; *see also* Air
 Corps, U. S. Army; Bureau of Aero-
 nautics, U. S. Navy
 Miller, Dick, 154
 Miller, W. T., 477
 Mitchell, William D., 51
 Moffat, H. U., 56
 Moffett, Rear Adm. William A., 74, 76,
 480, 481
 Moffit, John C., 154
 Mollison, Capt. James A., 90, 92-95, 381,
 382
 Mollison, Mrs. James A., *see* Johnson, Amy
 Monocoupe Corporation, 244, 254, 328
 Monro, Dana, 54
 Montenegro, Conchita, 57
 Montreal Light Plane Club, 138
 Moor, Robert D., 381
 Morgan, Thomas A., 447, 452
 Morse, Walter F., 153
 Muncie, Ind., airport, 117
 Municipal University of Wichita, 167
 Myers, Al D., 135
 Myers, B. F., 482
- N
- Nashville Banner, 156
 National Advisory Committee for Aero-
 nautics, 141, 146, 382; appropriations,
 431-432; organization, 480
 National Aeronautic Association of U. S.
 A., Inc., 382, 480
 National Aeronautic Magazine, a publica-
 tion, 452
 National Air Races, 101, 102, 138, 383,
 400-413
 National Air Transport, Inc., 36, 45
 National Aircraft Show, 381
 National Association of State Aviation Offi-
 cials, 163
 National aviation policy, *see* Governmental
 policy
 National Balloon Race, 87, 100, 382, 398
 National Flying Services, Ltd., 213
 National Guard, 13, 475
 National Parks Airways, Inc., 24, 28, 42,
 155
 Navy, *see* Bureau of Aeronautics, U. S.
 Navy
 Neely, F. R., 477
 Neri, Lieut. Ariosto, 101
 Netherlands, 222-224
 Netherlands East Indies, 224-225
 New England Airways, 194
 New Mexico College of A. & M. A., 167
 New Orleans, La., airport, 112
 New York, N. Y., airport, 115
 New York University, 167, 168, 171
 New Zealand, 225
 New Zealand Airways, Ltd., 225
 Newark, N. J., airport, 114, 116, 118
 Newcomer, Edna, 98, 383
 Newhamco Air Service, 124

- Newspapers, 149-156; directory of editors, 454-457
- Nicaragua, 186
- Nichols, Ruth, 381
- Nippon Koku Kabushiki Kaisha, 221
- Nippon Koku Yuso Kenkyo-jo, 221
- Noble, Edward, 137
- Noble, Robert, 137
- Norris, George W., 51
- Norske Luftruter A/S, 225
- North American Aviation, Inc., 32, 34, 36, 174, 184, 188, 248
- Northwest Airways, Inc., 28, 34, 40, 42, 178
- Norway, 225
- Norwegian Air Transport Co., *see* Norske Luftruter A/S
- Nunnally, Winship, 481
- Nye, Gerald P., 51
- O**
- O2L, OL-9*, *see* Keystone Aircraft Corp.
- O2U-4*, *see* Vought, Chance, Corp.
- O-39*, *see* Curtiss Aeroplane and Motor Co., Inc.
- Oakland, Cal., airport, 108
- Oesterreichische Luftverkehrs A. G., 195-196
- Oesterreichische Phoenix Flugzeugwerke, 195
- Official Aviation Guide of the Airways, a publication, 452
- Officine Ferroviarie Meridionali, 220
- Ohio State University, 167
- OJ-2*, *see* B/J Aircraft Corp.
- Oklahoma Agricultural and Mechanical College, 171
- Oklahoma City, Okla., airport, 112, 117
- Oklahoma City Times, 156
- Omaha Air Races, 382
- O'Meara, J. K., 138, 382
- Oregon State College, 168
- Oregonian, 156
- Orion*, *see* Lockheed Aircraft Corp.
- Orr, George W., 447
- Osakeyhtiö Sääski, 205
- Osborn, Earl D., 447
- Osprey*, *see* Curtiss-Wright Airplane Co.
- Owen, Ruth Bryan, 53
- P**
- P6-E*, *see* Curtiss Aeroplane and Motor Co., Inc.
- P-12F*, *see* Boeing Airplane Co.
- Pacemaker*, *see* Bellanca Aircraft Corp.
- Pacific Air Transport, 36, 45
- Pacific Alaska Airways, Inc., 174
- Pacific International Airways, Inc., 174
- Pacific Zeppelin Transport Co., 80
- Packard Motor Car Co., 330, 350, 342, *D R-980*, 341
- Palestine, Tex., airport, 117
- Pan American Airways, Inc., 17, 24, 34, 44, 54, 58, 110, 151, 174-178, 180, 182, 183, 184, 185, 186, 187, 188, 189, 190, 244, 254, 370
- Pan American-Grace Airways, Inc., 54, 174, 178, 180, 182, 183, 184, 185, 187, 188, 189
- Panair do Brazil, 182
- Panama, 186-187
- Pangborn, Clyde, 89, 90
- Paragould, Ark., airport, 117
- Paraguay, 187
- Patkin, Walter F., 477
- Parks, Oliver L., 447
- Parks Air College, 122, 124
- Parts, 367-378; directory of manufacturers, 449-450, 486-489
- Patton, W. Blaine, 153
- Paul, Lieut. W. J., 87, 100, 382, 398
- Paulett, Richard S., 477
- Pawtucket, R. I., airport, 115
- PCA-2, PCA-3, PA-8, PA-18, PA-19*, *see* Pitcairn Aircraft, Inc.
- Penn School of Aviation, 122-123
- Penn State College, 168
- Pennsylvania Airlines, Inc., 24, 28, 34, 42, 124
- Pensacola, Fla., airport, 117
- Perkins, Randolph, 53
- Persia, 226
- Peru, 187-188
- Petersen, Carl, 98
- Philippine Aerial Taxi Co., 226
- Philippine Islands, 226
- Piaggio, 220
- Piccard, Auguste, 90, 100, 382
- Pickford, Mary, 56-57
- Piersol, James V., 154
- Pierson, Paul, 54
- Pilgrim*, *see* American Airplane and Engine Corp.
- Pilgrim*, blimp, 84
- Pilots, licensed, 122, 129-130, 142; *graph*, 12
- Pioneer Instrument Co., 368, 374
- Pisculli, Dr. Leon M., 98, 383
- Pitcairn Aircraft, Inc., 244, 254; *Autogiro PCA-2, PCA-3, 286, PA-18, 287, PA-19, 285; PA-8, 265*
- Pittman, Key, 51
- Pittsburgh, Pa., airport, 115, 117
- Pittsburgh Aviation Industries Corp., 34, 42, 122
- Pittsburgh Screw and Bolt Co., 377
- Pobjoy Airmotors, Ltd., 215
- Poland, 226, 227
- Polando, John, 90

Polskie Linie Lotnicze, 204, 222, 226, 227
 Popular Aviation, a publication, 453
 Port Huron, Mich., airport, 117
 Portland Airways, Inc., 42
 Portola, Cal., airport, 117
 Portugal, 227
 Post, Wiley, 89, 90, 92, 95
 Post Office Dept., *see* Air Mail
 Postal Telegraph-Cable Co., 28
 Prall, Anning S., 53
 Pratt, Brig. Gen. Henry C., 475, 480
 Pratt, John, 132
 Pratt and Whitney Aircraft Co., 246, 322-324, 326, 330-331; *Hornet B1*, 347, 348; *Hornet C*, 346; *Twin Wasp*, 351, 352; *Twin Wasp Jr.*, 349, 350; *Wasp*, 344, 345; *Wasp Jr.*, 343
 Princeton University, 168
 Pritchard, Robert J., 480
 Private flying, 12-13, 129-134, 136-138; summary, 417
Privateer, *see* Amphibions, Inc.
 Propellers, 242, 372
Puritan, blimp, 84, 85
 Putnam, Carlton, 136
 Putnam, George Palmer, 91, 132
 Putnam, Mrs. George Palmer, *see* Earhart, Amelia
 Pyle National Co., 368

Q

Queensland and Northern Territories Aerial Services, Ltd., 193

R

R, *see* Stinson Aircraft Corp.
 R-5, *see* Kinner Airplane and Motor Corp., Ltd.
 R-680, R-680-BA, *see* Lycoming Mfg. Co.
 R-690, *see* Continental Aircraft Engine Co.
 Radio, 145, 146, 368-370; directory of manufacturers, 489
 Radiomarine Corporation, 368, 370
 Railway Express Agency, 28, 42, 46, 47
 Randolph Field, 66, 116
Ranger, carrier, 72
 Rapid Air Transport, Inc., 42-44
Raven, *see* Curtiss Aeroplane and Motor Co., Inc.
 Record flights, 89-103, 384-398; altitude, 100; distance, 93-95, 101-102; speed, 100-101; transcontinental, 102
 Redwing Aircraft Co., Ltd., 215
 Reed, David A., 52
 Reed Airline, 44
 Reichers, Lou T., 98, 381
 Reid, Frank R., 53
 Reid, Henry J. E., 480

Reining, R. R., 477
Reliance, blimp, 84
 Renard, G., 196
 Rentschler, F. B., 447
Resolute, blimp, 84
 Reynolds, Libby Holman, 58
 Rhonie, Aline, 137
 Rignot, Commandant Georges A., 382
 Rinehart, Mary Roberts, 57
 Robbins, Richard W., 34, 447
 Robida, Henri, 381
 Roebling's, John A., Sons Co., 376
 Rogers, Edith N., 53
 Rogers, Will, 57
 Roosevelt, Mrs. Edith Kermit, 50
 Roosevelt, Pres. Franklin D., 7, 49
 Roosevelt, Mrs. Franklin D., 49, 50
 Roosevelt, Theodore, 49
 Roosevelt, Theodore, jr., 54
 Root, W. Russell, 479
 Ross, Raymond S., 477
 Rossi, Maurice, 102, 381
 Roth, Gert von, 97, 383
 Round-the-world flights, 96-98
 Royal Dutch Air Lines, *see* Koninklijke Luchtvaart Maatschappij voor Nederland en Kolonien
 Royal Dutch Indian Air Line, *see* Koninklijke Nederlandsch-Indische Luchtvaart Maatschappij
 Rumania, 227
 Rumsey, Charles Cary, jr., 137
 Russell, Frank H., 447, 479
 Rutherford, Jack, 137
 Ryan School of Aeronautics, 122, 124

S

S-38, S-39, S-40, *see* Sikorsky Aviation Corp.
 Sabena, *see* Société Anonyme Belge d'Exploitation de la Navigation Aérienne
 Safair Schools, 122, 124
 St. John's College of Law, 171, 172
 St. Louis, Mo., airport, 108, 115
 St. Louis Aircraft Corp., 255
 Salaman, Peggy, 90
 Salathe, William F., 156
 Salel, Jean, 381
 San Antonio Evening News, 156
 San Antonio Express, 156
 San Diego, Cal., airport, 114
 San Francisco, Cal., airport, 119
 Sanborn, John A., 479
 Sanford, Fla., airport, 117
 Santos-Dumont, Alberto, 382
Saratoga, carrier, 69, 72
 Saunders, Everett, 58
 Scadta, *see* Sociedad Colombo-Alemana de Transportes Aereos

- Scandinavian Air Express Line, *see* Akth. Aerotransport
- Scarab, Scarab Jr.*, *see* Warner Aircraft Corp.
- Schaife, A. J., 482
- Schall, Thomas D., 52
- Schempp, Martin, 138
- Schoonmaker, J. M., jr., 447, 452
- Schuyler, Karl C., 53
- Schwarz, Charles, 153
- Scintilla Magneto Co., 368, 370
- Scott, C. W. A., 94-95, 381
- Scaled Power Corp., 135
- Seaplane anchorages, 470-472
- Security Sportswear Co., 377
- Settle, Lt. Comdr. T. G. W., 86, 100, 383, 399
- Seymour, Lester D., 32
- Sharples, Lawrence P., 132
- Shell Oil Co., 156
- Sherwood, Robert, 57
- Shreveport, La., airport, 116
- Shrike*, *see* Curtiss Aeroplane and Motor Co., Inc.
- Siam, 228
- Sibley, Eugene, 477
- Siemens and Halske A. G., 211
- Sikorsky Aviation Corp., 176, 244, 246, 254; *S-38*, 267; *S-39*, 288; *S-40*, 266
- Sioux City Tribune, 154
- 16-E*, *see* Curtiss-Wright Airplane Co.
- SKF Industries, Inc., 377
- Skinner, Otis, 57
- Skoda Works, 201
- Sky Lines, a publication, 453
- Sky Specialties Corp., 372
- Skyrocket*, *see* Bellanca Aircraft Corp.
- Skyways, Inc., 124
- Smart, F. G., jr., 481
- Smith, Ellison D., 52
- Smith, J. A. B., 447, 452
- Smith, John B., 381
- Smith, Stanley, 138
- Smith Engineering Co., 368, 372
- Smoot, Reed, 52
- Snell, Walter, 138
- Soaring Society of America, Inc., 138
- Sociedad Colombo-Alemana de Transportes Aereos, 174, 184
- Società Aerea Mediterranea, 219
- Società Anonima Navigazione Aerea, 219
- Società Anonima Nord Africa Aviazione, 219
- Società Avio Linee Italiane, 219
- Società Idrovolanti Alta Italia, 220
- Società Italiana Ernesto Breda, 220
- Società Italiana Servizi Aerei, 219
- Société Anonyme Belge d'Exploitation de la Navigation Aérienne, 196-198
- Société d'Enterprises Generales d'Aéronautique, 196
- Société Générale de Transportes Aériens, 207-208
- Society of Automotive Engineers, Inc., 482
- Society of British Aircraft Constructors, Ltd., 214
- Solberg, Thor, 98
- Somers, Andrew S., 53
- Soong, T. V., 200
- Soucek, Lieut. Apollo, 90, 100
- South America, 173-190
- South Bend, Ind., airport, 117
- South Manchuria Railway, 200, 221
- Southern Aviation, a publication, 453
- Soviet Civil Aviation Trust, 234
- Spain, 228-229
- Spaulding, Roland H., 172
- Speedmail*, *see* Stearman Aircraft Co.
- Speedwing*, *see* Curtiss-Wright Airplane Co.
- Sperry Gyroscope Co., 368, 373-374
- Spirit Lake, Iowa, airport, 117
- Sportsman Pilot, a publication, 453
- Springdale, Ark., airport, 117
- Stainforth, Lieut. George H., 90, 101, 381
- Stampe and Vertongen, 196
- Stanavo Specification Board, Inc., 322
- Standard Oil Co., 190
- Standard Oil Company of N. Y., 134
- Stanford University, 167, 168
- Stanton, C. I., 477
- State College of Washington, 170
- Statni Aerolinie, 201
- Stearman Aircraft Co., 244, 246, 255; *C 3R*, 289; *Speedmail*, 268
- Steiner, Frederick, 52
- Sternberg, Joseph von, 57
- Stimson, Henry L., 51
- Stinson Aircraft Corp., 244, 246, 255; *R*, 290; *U*, 269
- Store, Gordon, 90
- Straits Settlements, 229
- Strassman, Antoine, 95
- Strong, Earle R., 477
- Stuart, Nick, 57
- Sumitomo Company, 200
- Summerill Tubing Co., 376
- Sunnyvale, Cal., airship dock, 116
- Supplies, 367-378; directory of manufacturers, 449-450, 486-489
- Sutherin, J. W., 482
- Sweden, 229-231
- Swift*, *see* Curtiss Aeroplane and Motor Co., Inc.
- Swing, Philip D., 53
- Swissair, 207, 231, 232
- Switlik Parachute and Equipment Co., 378
- Switzerland, 231-232
- Syracuse University, 168

T

- Taliaferro, A. Pendleton, jr., 477
 Tashman, Lilyan, 57
 T. A. T.-Maddux Air Lines, Inc., 34, 36
 Tata Sons, Ltd., 217
 Taxation, 159-160; state gasoline tax summary, 434
 Taylor, Charles M., 137
 Taylor, David W., 480
 Taylor, R. F., 481
 TC-13, airship, 82-84
 Thaden, Louise, 382
 Thatcher, Maurice, 53
 Thomas, Elmer, 52
 Thompson, Edwin G., 34
 Thompson, L. S., Speed Trophy, 381
 Thompson Products, Inc., 377
 Thurber, Burton B., 156
 Thurston Cutting Corp., 377
 Tibbett, Lawrence, 57
 Tide Water Oil Corp., 135
 Tokyo Koku Yuso-sha, 221
 Trade index, 484-492
 Train, Arthur, 57
 Trans-Adriatica, 219
 Trans-Atlantic flights, 91-100
 Transamerican Airlines Corp., 20, 24, 28, 34, 44, 57, 153, 154, 251
 Transcontinental and Western Air, Inc., 17, 18, 20, 22, 28, 34-36, 44-45, 47, 50, 54, 56, 153
 Trinidad, 188
 Trippe, J. T., 447
 Tulsa, Okla., airport, 108, 118
 Turkey, 232-233
 Turner, Roscoe, 102, 383
 2T-1A, 2T-1E, *see* Great Lakes Aircraft Corp.
 247, *see* Boeing Airplane Co.
 2500, *see* Packard Motor Car Co.

U

- U, *see* Stinson Aircraft Corp.
 Udd, John, 134
 Ulbrich, William, 98, 383
 UMCA, *see* Uraba, Medellin and Central Airways
 Undercarriage, 374-376
 Union Airways, 233
 Union of South Africa, 233
 Union of Soviet Socialist Republics, 234
 United Air Lines, 17, 18, 24, 28, 34, 36, 40, 45-46, 57, 59, 151, 155, 249, 381
 United Aircraft and Transport Corp., 36, 45, 122, 246, 248, 254, 255, 330
 U. S. Air Services, a publication, 453
 United States Airways, Inc., 28, 46
 United States Amateur Air Pilots Association, 137

- United States Military Academy, 168, 169
 Universal Model Airplane News, a publication, 453
 University of Akron, 86
 University of Alabama, 166, 167
 University of Arkansas, 172
 University of California, 167, 171
 University of Cincinnati, 166, 167, 171
 University of Colorado, 167, 172
 University of Detroit, 166, 171
 University of Iowa, 170
 University of Michigan, 167
 University of Minnesota, 167, 172
 University of Nebraska, 167
 University of Nevada, 167
 University of Oklahoma, 168
 University of Pittsburgh, 167
 University of South Dakota, 168
 University of Southern California, 167
 University of Tennessee, 172
 University of Texas, 172
 University of Toledo, 172
 University of Washington, 167, 168
 University of Wisconsin, 168
 Uppercu, I. M., 447
 Uraba, Medellin and Central Airways, 174, 184, 187
 Uruguay, 188-189
 Uwins, Capt. Cyril F., 100, 383

V

- V-65, *see* Vought, Chance, Corp.
 Vallee, Rudy, 57
 Vallejo, Cal., airport, 117
 Van Orman, Ward T., 87, 100
 Varney Air Ferries, 47
 Varney Air Lines, Inc., 36, 45
 Varney Air Services, Ltd., 47
 Varney Speed Lines, 47
 Vellumoid Company, 377
 Venezuela, 189-190
 Vero Beach, Fla., airport, 117
 Victory, John F., 480
 Virginia Polytechnic Institute, 168
 Volunteer, blimp, 84, 85
 Von Gronau, Capt. Wolfgang, *see* Gronau, Capt. Wolfgang von
 Vought, Chance, Corp., 244, 246, 255; O2U4, 319; V-65, 318

W

- Waco Aircraft Co., 244, 255; A, 291; C, 292; F, 293; F2, 294
 Wadsworth, E. B., 482
 Wagner, Robert F., 52
 Walker, Don, 135
 Walker, James J., 92
 Walker, Walter F., 52, 53
 Wall, Wm. Guy, 482

- Walls, H. J., 477
 Walsh, Frank J., 452
 Walsh, Thomas J., 154
 Walter, K., and Co., 330
 Warm Springs, Ga., airport, 117
 Warner Aircraft Corp., 326, 331; *Scarab*, 354; *Scarab Jr.*, 353
 Warner, Edward P., 480
 Warner, John A. C., 482
 Washington Evening Star, 152
Wasp, *Wasp Jr.*, see Pratt and Whitney Aircraft Co.
 Wasser und Luftfahrzeugbau G.m.b.H., 211
 Weather Bureau, 483
 Weber, William, 483
 Wedell, James R., 102, 383
 Wellington Sears Co., 377
 Wells, H. G., 57
 West Palm Beach, Fla., airport, 110
 Western Air Express, 24, 28, 34, 36, 47, 57, 59
 Western Australian Airways, Ltd., 193
 Western Electric Co., 368, 369
 Western Flying, a publication, 453
 Western Union Telegraph Co., 28, 44
 Westinghouse Electric and Mfg. Co., 368, 372
 Westover, Brig. Gen. Oscar, 472
 Wheat, George S., 447, 452
Whirlwind, see Wright Aeronautical Corp.
 White, E. R., 482
 White, J. J., 137
 White, John Campbell, 54
 White, S. O., 482
 White, S. S., Dental Mfg. Co., 368, 370
 Wielemans, 196
 Wilbur, Ray Lyman, 51
 Willebrandt, Mabel Walker, 58
 Willgoos, A. V. D., 482
 Williamsburg, Va., airport, 117
 Willoughby, A. O., 482
 Wilson, Eugene E., 479
 Wilson, R. E., 482
 Winchester, J. F., 482
 Wirges, Joe B., 152
 Wise, Lieut. Walter, 152
 Withrow, Gardner R., 53
 Wolf Point, Mont., airport, 117
 Wood, John S., 53
 Wood, William R., 53
 Woolson, H. T., 482
 Worcester Polytechnic Institute, 167
 Wotowitch, R. A., 447
 Wright Aeronautical Corp., 246, 322-324, 326, 331, 332; *Curtiss Challenger*, 356; *Curtiss Conqueror*, 363, 364; *Curtiss Super-Conqueror*, 365; *Cyclone E*, 360; *Cyclone F*, 361; *Gipsy*, 355; *Whirlwind*, 357, 358, 359, 362
 Wright, Orville, 1, 383, 480
 Wright, Wilbur, 1, 381, 383
 Wyoming Air Service Inc., 48

X

- XB-907*, see Martin, Glenn L., Co.
XF6B-1, *XP-936*, see Boeing Airplane Co.
XFJ-2, see B/J Aircraft Corp.
XP-934, see Curtiss Aeroplane and Motor Co., Inc.

Y

- Y1B-9A*, see Boeing Airplane Co.
Y1P-16, see B/J Aircraft Corp.
YA-8, *YO-40*, see Curtiss Aeroplane and Motor Co., Inc.
 Yale University, 168
 Yancey, Capt. Lewis A., 134, 383
YO-27, see General Aviation Mfg. Corp.
 Young, Clarence M., 477, 481, 482
 Young, H. E., 447
 Young, Sanborn, 132
 Yugoslavia, 234

Z

- Zimbalist, Efram, 58
 Zimmer, Eduard, 97
 Zwirko, Franciszek, 227, 382

